

Register your instrument!
www.eppendorf.com/myeppendorf



CryoCube® F101h

Operating manual

Copyright© 2019 Eppendorf AG, Germany. All rights reserved, including graphics and images. No part of this publication may be reproduced without the prior permission of the copyright owner.

Eppendorf® and the Eppendorf Brand Design are registered trademarks of Eppendorf AG, Germany.

CryoCube® is a registered trademark of Eppendorf AG, Germany.

Registered trademarks and protected trademarks are not marked in all cases with ® or ™ in this manual.

U.S. Patents are listed on www.eppendorf.com/ip

Table of contents

1	Operating instructions	7
1.1	Using this manual	7
1.2	Danger symbols and danger levels	7
1.2.1	Danger symbols	7
1.2.2	Danger levels	7
1.3	Symbols used	8
1.4	Operating manual version overview	8
2	Safety	9
2.1	Intended use	9
2.2	Warnings for intended use	9
2.2.1	Devices with flammable refrigerant	10
2.3	User profile	10
2.4	Personal protective equipment	11
2.5	Information on product liability	11
2.6	Maintenance and repairs	11
2.7	Electromagnetic compatibility	12
2.7.1	Europe	12
2.8	Warning symbols on the device	13
3	Product description	17
3.1	Product overview	17
3.1.1	Overall view	17
3.1.2	Interfaces	18
3.1.3	Mains/power switch	19
3.2	Features	19
3.3	Alarms	20
3.4	Delivery package	21
3.4.1	Device and accessories	21
3.4.2	Documents	21
3.5	Accessories	21
3.5.1	Back-up systems	21
3.5.2	Chart recorder	21
3.5.3	Cardboard boxes and box dividers	22
3.5.4	Eppendorf Storage Box	22
4	Installation	23
4.1	Selecting the location	23
4.2	Preparing installation	24
4.2.1	Unpacking the device	24
4.2.2	Checking the delivery	24
4.2.3	Transporting the device to the location	24
4.2.4	Setting up the device	24
4.3	Connecting the device to the voltage supply	25
4.4	Connecting the device to external systems	26
4.4.1	Remote alarm interface	26
4.4.2	RS-485 interface	27
4.5	Switching the device on	27

Table of contentsCryoCube® F101h
English (EN)

4.5.1	Enabling the back-up circuit.	28
4.5.2	Switching the device on at the mains/power switch.	28
4.6	Basic device settings.	28
5	Operation.	29
5.1	Opening the outer door.	29
5.2	Loading the device	29
5.3	Locking the outer door	30
5.4	Pressure compensation.	30
5.5	Switching off the device	30
5.5.1	Disabling the back-up circuit	30
5.5.2	Disconnecting the device from the voltage supply.	31
6	Software	33
6.1	Overview of the control panel	33
6.2	Checking parameters	34
6.2.1	Displaying the set temperature for the interior of the device.	34
6.2.2	Displaying the offset for the interior temperature	34
6.2.3	Displaying the alarm limits for the interior temperature	34
6.2.4	Displaying the alarm delay time	34
6.2.5	Displaying the ambient temperature.	34
6.3	Working with a lock code	34
6.3.1	Unlocking and locking the device.	34
6.3.2	Activating and changing the lock code.	35
6.3.3	Deactivating the lock code	36
6.4	Programming parameters.	36
6.4.1	Setting the set temperature value for the interior.	36
6.4.2	Setting an offset for the set temperature in the interior	37
6.4.3	Setting alarm limits.	37
6.4.4	Setting an alarm delay time	38
7	Maintenance	39
7.1	Service schedule	39
7.2	Defrosting the device	39
7.3	Cleaning and decontamination	40
7.3.1	Cleaning the device.	40
7.3.2	Cleaning and disinfecting the control panel	40
7.3.3	Removing the inner door	41
7.3.4	Installing the inner door again	41
7.3.5	Cleaning the seals.	41
7.3.6	Cleaning the air filter and the air intake grille	42
7.3.7	Decontaminating the interior	42
7.4	Checking the alarm	43
7.4.1	Checking indicator lights and the signal tone.	43
7.4.2	Checking the alarm in the case of a mains/power outage	43
7.5	Safety checklist	44

8	Troubleshooting	45
8.1	General errors	45
8.2	Error messages	45
8.3	After a mains/power failure	46
8.4	Heating up of the interior	46
9	Transport, storage and disposal	47
9.1	Decommissioning	47
9.2	Transport	47
9.2.1	Preparing the device for transport	48
9.2.2	Transporting the device	48
9.3	Shipment	49
9.3.1	Shipping regulations	49
9.3.2	Shipping the device	49
9.4	Disposal	50
10	Technical data	51
10.1	Power supply	51
10.2	Ambient conditions	51
10.2.1	Operation	51
10.2.2	Storage	51
10.3	Dimensions	52
10.3.1	External dimensions	52
10.3.2	Internal dimensions	53
10.3.3	Packing dimensions	53
10.4	Weight	53
10.5	Noise level	53
10.6	Interfaces	53
10.7	Temperature control	54
10.7.1	Temperature range	54
10.7.2	Times for cooling and heating the interior	54
10.7.3	Cooling of the refrigeration cycle	54
10.7.4	Refrigerant	54
10.8	Additional specifications	54
10.8.1	Capacity and carrying capacity	54
10.8.2	Materials	54
11	Ordering information	55
11.1	Accessories	55
11.1.1	Back-up systems	55
11.1.2	Chart recorder	55
11.1.3	Racks	55
11.1.4	Cardboard boxes and box dividers	56
11.1.5	Eppendorf Storage Boxes	56
11.1.6	VisioNize system	57
	Index	58

1 Operating instructions











1.1 Using this manual

- ▶ Read this operating manual completely before using the device for the first time. Observe the instructions for use of the accessories where applicable.
- ▶ This operating manual is part of the product. Please keep it in a place that is easily accessible.
- ▶ Enclose this operating manual when transferring the device to third parties.
- ▶ The current version of the operating manual for all available languages can be found on our webpage www.eppendorf.com/manuals.

1.2 Danger symbols and danger levels

1.2.1 Danger symbols

The safety instructions in this manual have the following danger symbols and danger levels:

	Risk of tipping over		Electric shock
	Highly flammable substances		Explosive substances
	Low temperatures		Biohazard
	Heavy load		Risk of crushing
	Hazard point		Material damage

1.2.2 Danger levels

DANGER	<i>Will</i> lead to severe injuries or death.
WARNING	<i>May</i> lead to severe injuries or death.
CAUTION	May lead to light to moderate injuries.
NOTICE	May lead to material damage.

1.3 Symbols used

Depiction	Meaning
1. 2.	Actions in the specified order
▶	Actions without a specified order
•	List
<i>Text</i>	Display or software texts
i	Additional information

1.4 Operating manual version overview

Version	Date	Change
00	July 2019	Newly created

2 Safety

2.1 Intended use

CryoCube ULT freezers are designed to provide an ultra-low temperature environment for storing scientific research materials. They allow for storage of samples at ultra-low temperatures of -50 °C to -86 °C at a maximum ambient temperature of 32 °C.

All country-specific safety requirements for operating electrical equipment in laboratories must be observed.

2.2 Warnings for intended use



DANGER! Risk of severe injury from climbing onto the device

The device cannot carry the weight of a person. If the device tips over and falls on a person, this person will be injured.

The device may become damaged.

- ▶ Do not climb onto the device.
- ▶ Do not pull yourself up on the device or the outer door.



WARNING! Risk of explosion

- ▶ Do not operate the device in areas where work with explosive substances is carried out.
- ▶ Do not store explosive or highly reactive substances in the device.
- ▶ Do not use the device to store substances that may generate an explosive atmosphere.
- ▶ Do not store any aerogenic substances in the device, e.g., dry ice.



WARNING! Lethal voltages inside the device.

If you touch any parts which are under high voltage you may experience an electric shock. Electric shocks cause injuries to the heart and respiratory paralysis.

- ▶ Ensure that the housing is closed and undamaged.
 - ▶ Do not remove the housing.
 - ▶ Ensure that no liquids can penetrate the device.
- Only authorized service staff may open the device.



WARNING! Electric shock due to damage to the device or unsuitable power cable

If you touch a damaged or unsuitable mains/power cord, you may experience an electric shock. Electric shocks cause injuries to the heart, respiratory paralysis and burns.

- ▶ If the supplied mains/power cord is defective, replace it with a mains/power cord and a plug of the same type.

**WARNING! Damage to health due to infectious liquids and pathogenic germs.**

- ▶ When handling infectious liquids and pathogenic germs, observe the national regulations, the biosafety level of your laboratory, the material safety data sheets, and the manufacturer's application notes.
- ▶ Wear your personal protective equipment.
- ▶ For comprehensive regulations about handling germs or biological material of risk group II or higher, please refer to the "Laboratory Biosafety Manual" (source: World Health Organization, Laboratory Biosafety Manual, the current edition).

**CAUTION! Risk of burns from direct contact with cold surfaces.**

The temperature inside the device is low. Direct contact with the interior or samples can cause skin burns.

- ▶ Wear cold protection gloves when loading and unloading the device.

**NOTICE! Damage to the device during transport**

Improper transportation will damage the device.

- ▶ Transport the device with a sufficient number of helpers.
- ▶ Observe the transport instructions in the operating manual.

2.2.1 Devices with flammable refrigerant

**WARNING! Risk of fire due to escaping flammable refrigerants (R-170 and R-290)**

Refrigerant may leak out if a refrigeration cycle is faulty. The refrigerants R-170 and R-290 are flammable and can form explosive mixtures with the ambient air.

- ▶ Ensure adequate ventilation of the location.
- ▶ Observe the regulations of the owner.
- ▶ Do not allow the device to be maintained or repaired by anyone except authorized service technicians. Components may only be replaced with original spare parts of the same type.

2.3 User profile

The device and accessories may only be operated by trained and skilled personnel.

Before using the device, read the operating manual and the instructions for use of the accessories carefully and familiarize yourself with the device's mode of operation.

2.4 Personal protective equipment

Personal protective equipment protects your life and your health.

- ▶ Always wear the personal protective equipment required for the biosafety level and by the laboratory regulations.
- ▶ Always wear protective clothing, protective gloves, and safety boots.
- ▶ If additional protective equipment is required, this is indicated above the respective instruction.

2.5 Information on product liability

In the following cases, the designated protection of the device may be affected. Liability for any resulting damage or personal injury is then transferred to the owner:

- The device is not used in accordance with the operating manual.
- The device is used outside of its intended use.
- The device is used with accessories or consumables that are not recommended by Eppendorf.
- The device is maintained or repaired by persons not authorized by Eppendorf AG.
- The user makes unauthorized changes to the device.

2.6 Maintenance and repairs

Service technicians authorized by Eppendorf AG are appropriately trained and certified by Eppendorf AG.

- ▶ Do not allow the device to be maintained by anyone except service technicians who are authorized by Eppendorf AG.

For more information, please contact your Eppendorf partner or visit www.eppendorf.com.

- ▶ Do not allow the device to be maintained by anyone except service technicians who are accredited according to the national and local laws and safety regulations. Service technicians must hold valid certificates.

Australia, Queensland: the legal regulations state that service technicians require a valid gas work license for working on the refrigeration cycle.

Eppendorf AG uses high-quality components for the device which are manufactured especially for this purpose. These components ensure the safe function of the device. Eppendorf AG provides original spare parts for the service and repair of the device.

- ▶ Components may only be replaced by original spare parts of the same type.

Safety

CryoCube® F101h
English (EN)

2.7 Electromagnetic compatibility**2.7.1 Europe**

This is a class A product. In a domestic environment this product may cause radio interference in which case the user may be required to take adequate measures.

2.8 Warning symbols on the device

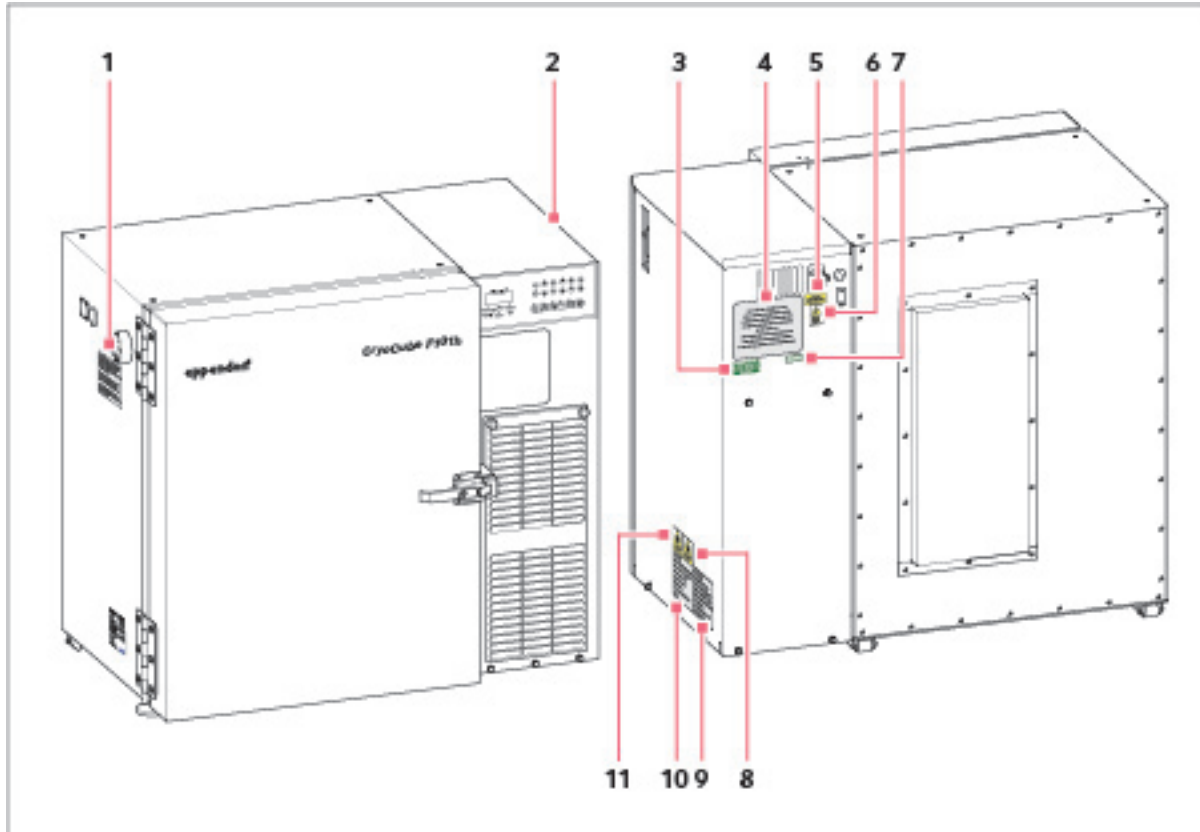



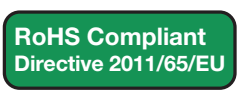

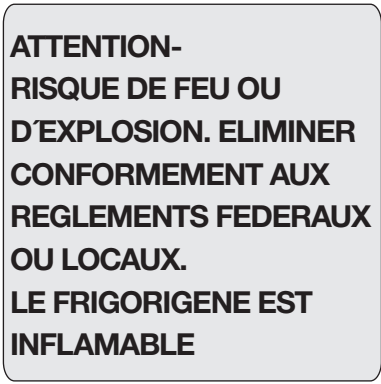
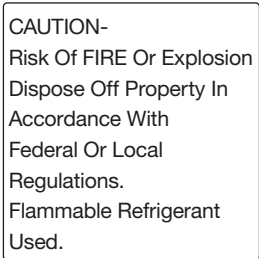



Fig. 2-1: Warning symbols on the outside of the device

	Warning symbol	Meaning
1	<p>THIS FREEZER IS FITTED WITH A HIGH EFFICIENCY DOOR SEAL. AFTER CLOSING THE FREEZER DOOR OR LID A VACUUM CAN BE CREATED INSIDE THE CABINET. THIS IS RELEASED THROUGH A SPECIAL VENT VALVE WHICH SHOULD BE KEPT CLEAR OF ICE. (REFER TO HANDBOOK)</p> <p>SHOULD THE VENT VALVE BECOME BLOCKED DO NOT TRY TO FORCE THE DOOR OR LID, WAIT, THE VACUUM WILL EVENTUALLY BE RELEASED BUT IT CAN TAKE 1 OR 2 HOURS.</p> <p>DO NOT DAMAGE THE HIGH EFFICIENCY SEAL OR STRAIN THE HINGES BY ALLOWING THE ICE TO FORM ON THE DOOR SEAL. WIPE CLEAN OCCASIONALLY.</p>	<p>The outer door of the device is fitted with a high efficiency seal. After closing the outer door or the lid a negative pressure can be generated inside the device. The negative pressure is equalized by the <i>auto vent</i> valve.</p> <p>Keep the <i>auto vent</i> valve free from ice.</p> <p>If the <i>auto vent</i> valve is blocked, do not use force to open the outer door or the lid. Wait until pressure equalization has taken place. Pressure equalization may take 1 – 2 hours.</p> <p>The formation of ice in the seal can damage the seal and hinges. To avoid any damage, clean the seal to remove ice.</p>

	Warning symbol	Meaning
2		Access for authorized service technicians only: Danger due to flammable gas, class 2
	<p>DANGER - Risk Of Fire Or Explosion Flammable Refrigerant Used. To Be Repaired Only By Trained Service Personnel. Do Not Puncture Refrigerant Tubing.</p> <p>ATTENTION- RISQUE DE FEU OU D'EXPLOSION. ELIMINER CONFORMEMENT AUX REGLEMENTS FEDERAUX OU LOCAUX. LE FRIGORIGENE EST INFLAMMABLE</p>	<p>Danger Risk of fire or explosion The device contains flammable refrigerant. Only qualified service technicians are permitted to repair the device. Do not puncture the refrigerant tubing.</p>
3	<p>ELECTRICAL SAFETY TEST</p> <p>DATE/INITIALS <input type="text"/></p> <p>APPL/REF No. <input type="text"/></p> <p>NEXT TEST DATE <input type="text"/></p> <p>PASSED</p>	The device has passed the electrical safety test.
4	<p>THIS EPPENDORF FREEZER IS FITTED WITH A CASCADE REFRIGERATION SYSTEM. SERVICE AND REPAIRS MUST BE CARRIED OUT BY A REFRIGERATION SPECIALIST APPROVED BY YOUR SUPPLIER. ANY REPAIRS CARRIED OUT BY UNAUTHORISED ENGINEERS COULD CAUSE SERIOUS DAMAGE TO THE SYSTEM AND MAY AFFECT YOUR WARRANTY.</p>	<p>The device may only be serviced and repaired by a qualified refrigeration specialist who has been authorized by Eppendorf AG. If the device is serviced or repaired by an unauthorized person, liability on part of Eppendorf AG shall cease immediately.</p>

	Warning symbol	Meaning
5		Only connect the device to a mains/power connection with a PE conductor.
6		Notice of a hazard point. Read the operating manual.
7		The device complies with RoHS Directive 2011/65/EC.
8		Danger from combustible refrigerant R-290.
9		Notice Risk of fire or explosion. Dispose of the device in accordance with laws and regulations. The device contains flammable refrigerant.
10		Notice Risk of fire or explosion. Dispose of the device in accordance with laws and regulations. The device contains flammable refrigerant.

SafetyCryoCube® F101h
English (EN)

	Warning symbol	Meaning
11		Danger from combustible refrigerant R-170.

3 Product description
3.1 Product overview
3.1.1 Overall view

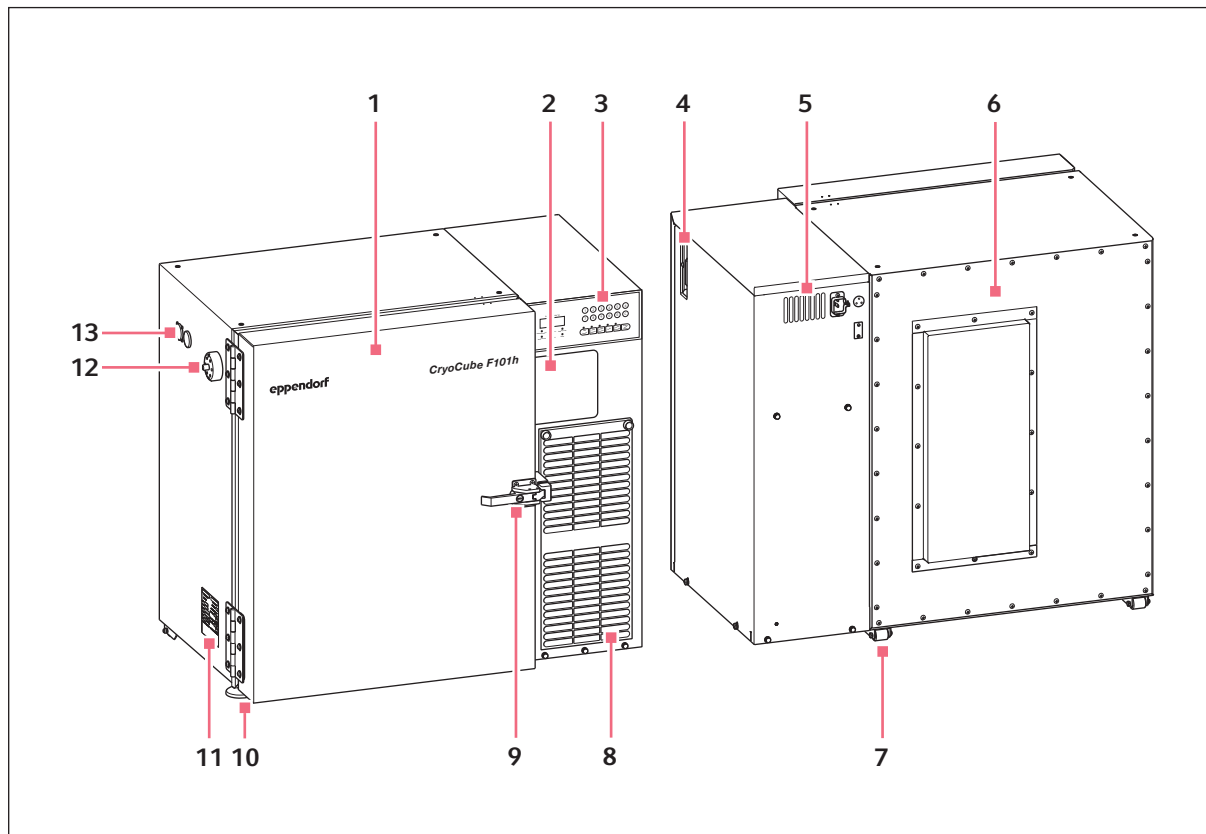

Fig. 3-1: Overall view F101h

- | | |
|--|---|
| 1 Outer door | 8 Air filter |
| 2 Space for an optional chart recorder | 9 Door handle lockable |
| 3 Control panel | 10 Leveling feet |
| 4 Battery switch and mains/power switch behind lockable cover | 11 Name plate |
| 5 Interfaces | 12 Auto vent valve Automatic pressure compensation |
| 6 Rear panel | 13 Access port |
| 7 Heavy-duty castors | |

3.1.2 Interfaces

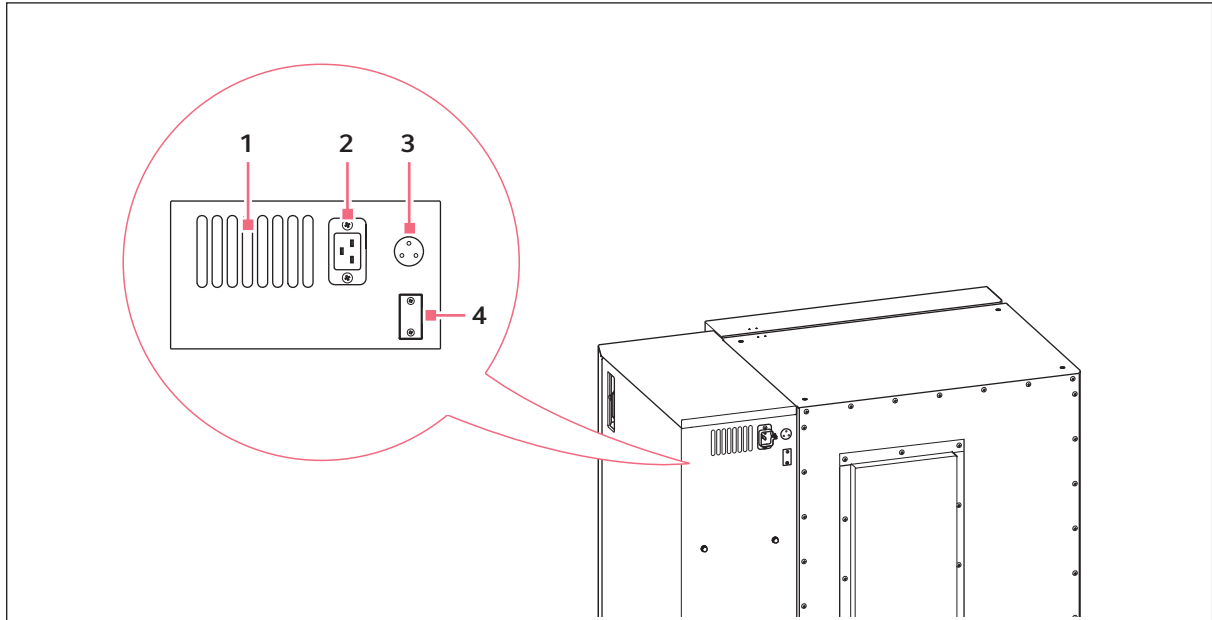

Fig. 3-2: Rear view

1 Ventilation grille

2 Mains/power connection

Connection for the mains/power plug

3 BMS remote alarm interface

Connection to a building management system

4 RS-485 serial interface

Connection to an external system

Only connect devices to the interfaces that comply with the IEC 60950 (UL 60590) standards.

3.1.3 Mains/power switch

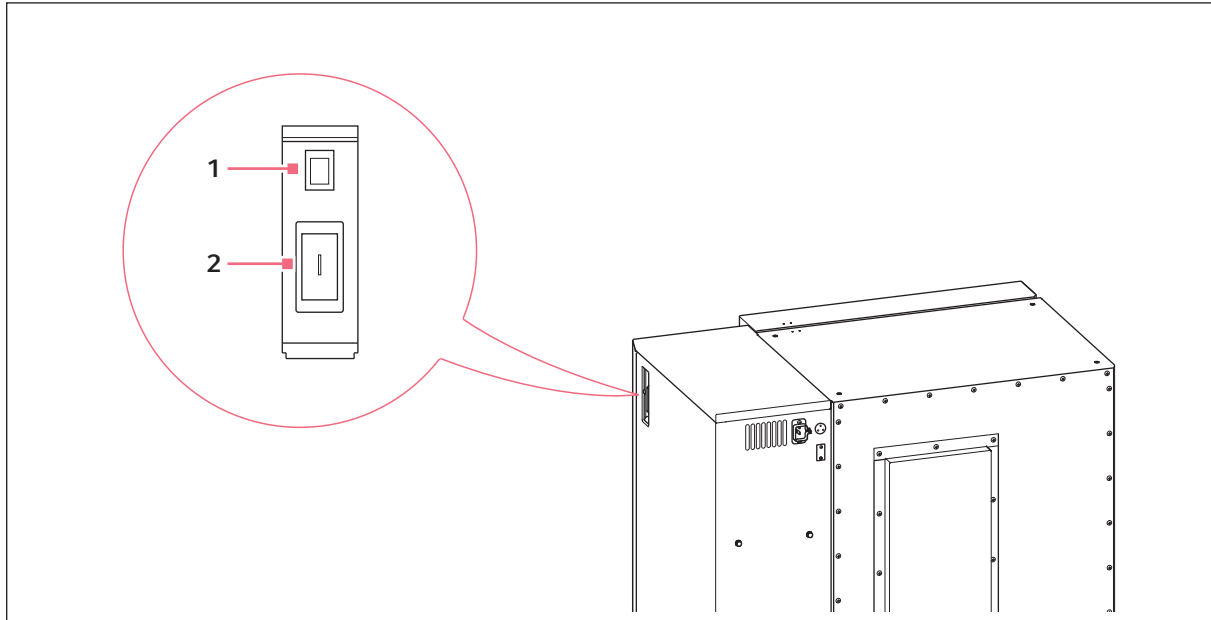

1 Battery switch

For activating the back-up circuit

2 Mains/power switch

Battery switch and mains/power switch are securely locked using a switch locking device. The switch locking device can only be opened and closed with the key supplied with the device.

3.2 Features

The CryoCube F101h is a ULT freezer for storing biological samples.

The device has a two-stage cascade refrigeration system with two closed refrigeration cycles. The refrigeration cycles are air-cooled.

The device is operated using the control panel. The control panel consists of a display, softkeys and indicator lights.

The device communicates with external systems over the interfaces. Alarms and other parameters are transmitted.

The outer door is locked and unlocked manually.

Product description

CryoCube® F101h
English (EN)

3.3 Alarms

When a safety-relevant situation occurs, the device will trigger an alarm. The following describes the situations which can trigger an alarm.

Alarms cannot be deactivated. The alarm will shut off as soon as the cause is remedied.

Interior temperature

The set alarm limit for the maximum or minimum temperature in the interior of the device is exceeded or not reached.

- The signal tone will sound after the set delay time.
- The *temp alarm* LED flashes on the control panel.

Mains/power outage

The mains/power supply to the device is interrupted. The back-up battery circuit is switched on.

- The signal tone will sound after the set delay time.
- The *power fail* LED flashes on the control panel.
- The display shows the interior temperature flashing in 10 s intervals.

Battery

The battery voltage is too low.

- The *battery low* LED on the control panel:
 - lights up if the battery needs to be charged.

System error

The device has a system error.

- The signal tone sounds.
- The *fault* LED on the control panel is lit.

Cleaning the air filter

The air filter is contaminated or blocked.

- The *filter clean* LED on the control panel is lit.

3.4 Delivery package

3.4.1 Device and accessories

Quantity	Description
1	ULT upright freezer
1 or 2	Mains/power cord (quantity depends on country)
1	Safety clamp for mains/power cord
2	Key for switch locking plate
2	Key for outer door
1	Plug for connection to the building management system

3.4.2 Documents

Quantity	Description
1	Operating instructions
1	Unpacking instructions
1	Certificate of conformity

3.5 Accessories

Optional accessories can be ordered separately. Information regarding accessories is available on our website: www.eppendorf.com.

3.5.1 Back-up systems

In the event of a mains/power outage, the battery-powered back-up system will start and cool the interior for a limited period of time. The back-up system is connected through the access port.

The following back-up systems are available:

- CO₂ back-up system for temperatures from -60 °C to -70 °C.
- LN₂ back-up system for temperatures down to -85 °C.

3.5.2 Chart recorder

The chart recorder records the interior temperature on a disk over a period of 7 days. The port for connection of the chart recorder is available in the device.

Pens and disks for chart recorders are available.

Product description

CryoCube® F101h
English (EN)

3.5.3 Cardboard boxes and box dividers

Fig. 3-3: Cardboard box and box divider

Cardboard boxes serve to store samples in tubes at temperatures down to -86°C . Cardboard boxes have a waterproof coating.

To sort your samples, you can insert box dividers into the cardboard boxes. Eppendorf AG cardboard boxes and box dividers are compatible with each other.

3.5.4 Eppendorf Storage Box

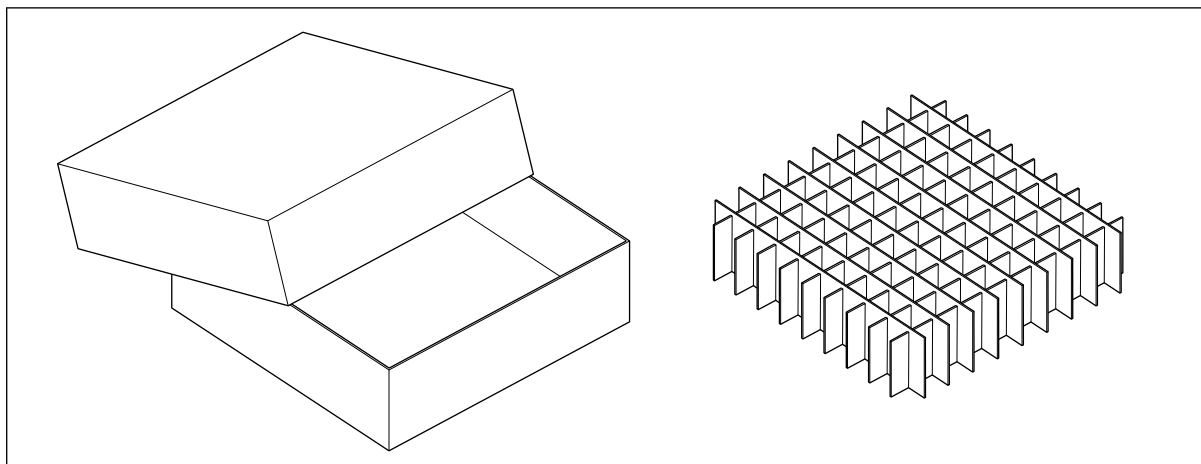
Fig. 3-4: Eppendorf Storage Box

Eppendorf Storage Boxes serve to store samples in tubes at temperatures down to -86°C .

Eppendorf Storage Boxes are made of polypropylene (PP) and are autoclavable.

4 Installation

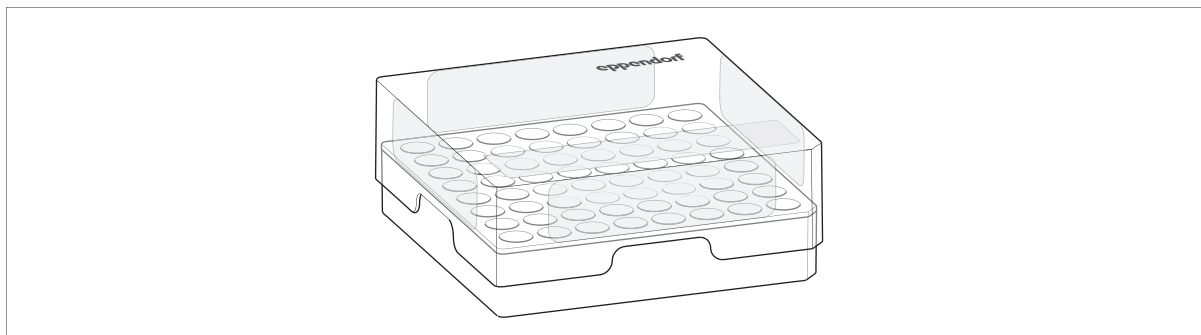
4.1 Selecting the location

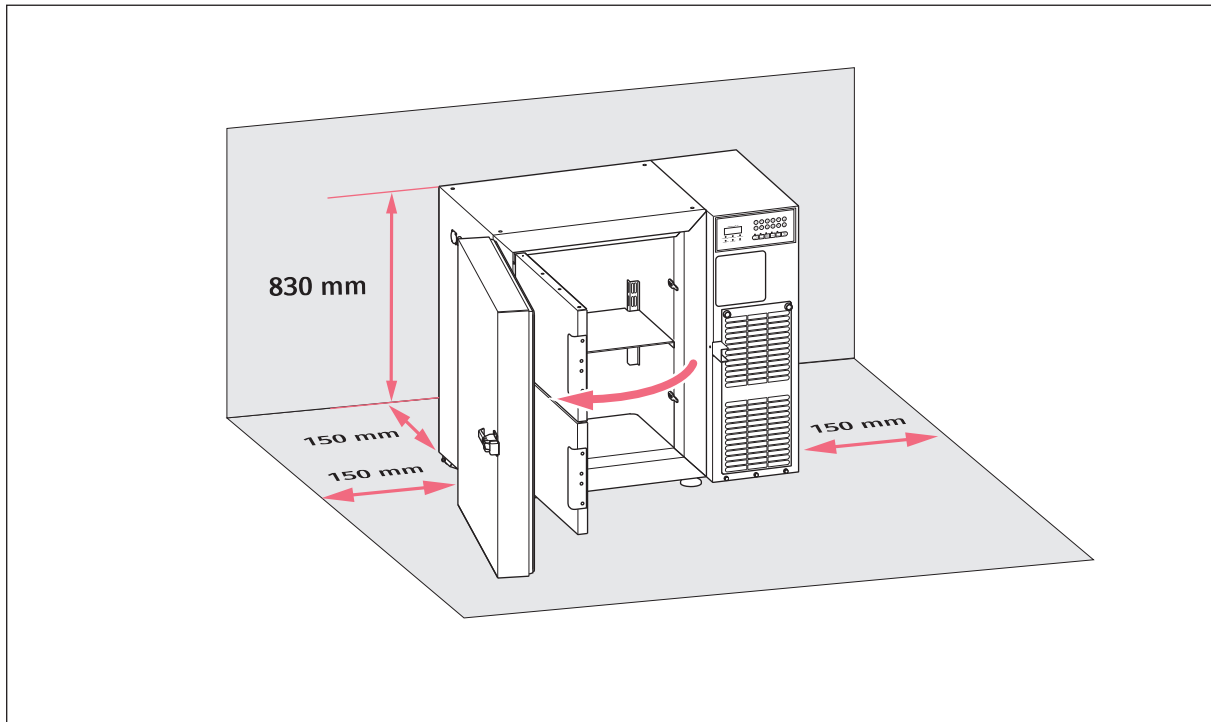

Information on ambient conditions, dimensions and weights can be found in the technical data.

Location in general

- The ambient conditions match the specifications set out in the Technical data chapter.
- The location is well ventilated or air-conditioned.
- The location is not next to heat sources.
- The location is protected against sparks and open fire.
- The location is protected against sparks and open fire.
- The floor space corresponds to the requirements in the technical data.
- The floor space is level, vibration-free and designed for the weight of the device.

Electrical connection

- Mains/power connection in accordance with the name plate
- The mains/power switch of the device and the disconnecting device of the power system circuit (e.g., residual current circuit breaker) are accessible during operation.



Contact your safety officer for information on further requirements when installing the device.

Installation

CryoCube® F101h
English (EN)

4.2 Preparing installation

4.2.1 Unpacking the device

1. Check the packaging for damage.
2. Unpack the device in accordance with the unpacking instructions.

4.2.2 Checking the delivery

1. Check the delivery for completeness.
2. Check the device and accessories for transport damage.
3. Do not commission the device if the packaging or the device is damaged. Contact the Eppendorf AG customer service or your Eppendorf partner.

4.2.3 Transporting the device to the location

**CAUTION! Risk of injury due to lifting and carrying of heavy loads**

The device is heavy. Lifting and carrying the device can lead to back injuries.

- ▶ Transport and lift the device with an adequate number of helpers only.
 - ▶ Use a transport aid for transporting the device.
-

Personal protective equipment

- Protective clothing, safety shoes

Prerequisites

- The location meets the requirements.
- ▶ Transport the device to the location (see *Preparing the device for transport on p. 48*).

4.2.4 Setting up the device

**NOTICE! Risk of material damage**

The device must not be stacked. Improper use may cause material damage.

- ▶ Do not install the device stacked on another device.
-

Prerequisites

- The device is placed in a suitable location.

1. Use the leveling feet to align the device. Rotate the leveling feet downward to do this.

4.3 Connecting the device to the voltage supply



WARNING! Danger due to incorrect voltage supply.

- ▶ Only connect the device to voltage sources which correspond with the electrical requirements on the name plate.
 - ▶ Only use earth/grounded sockets with a protective earth (PE) conductor.
 - ▶ Only use the mains/power cord supplied.
-

Prerequisites

- Mains/power connection in accordance with the name plate
1. If multiple mains/power cords have been supplied, select the appropriate one for the power supply voltage.
 2. Connect the mains/power cord at the rear of the device.

4.4 Connecting the device to external systems

4.4.1 Remote alarm interface



NOTICE! Risk of material damage

- ▶ Do not connect hazardous voltages to the remote alarm interface. Maximum nominal values are 24 V, 1 A.

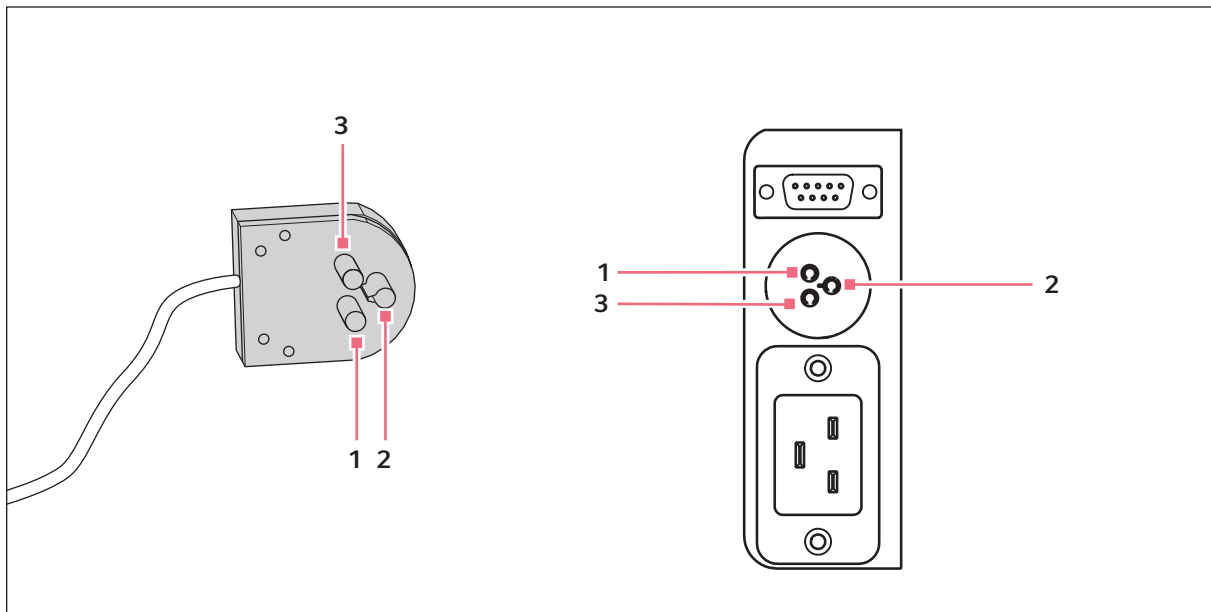

1 Pin 1 and socket 1

2 Pin 2 and socket 2

3 Pin 3 and socket 3

You can connect the device to a building management system via the remote alarm interface.

The following alarms are transferred to the building management system:

- Alarm in case of a mains/power outage
- Alarm indicating that the temperature inside the device is too high
- Alarm indicating that the temperature inside the device is too low

The plug is included in the delivery package. Connections must have double or reinforced insulation as described in DIN EN 61010-1.

4.4.2 RS-485 interface

You can connect the device to external monitoring systems via the RS-485 interface.

The RS-485 interface can be used to read out various parameters, such as the interior temperature. You can forward all alarms to an external system.

Connections must have double or reinforced insulation as described in DIN EN 61010-1.

4.5 Switching the device on



WARNING! Electric shock due to damage to the device or mains/power cord.

- ▶ Only switch on the device if the device and mains/power cord are undamaged.
- ▶ Only operate devices which have been installed or repaired properly.
- ▶ In case of danger, disconnect the device from the mains/power supply voltage. Disconnect the mains/power plug from the device or the earth/grounded socket. Use the isolating device intended for this purpose (e.g. the emergency switch in the laboratory).



NOTICE! Damage to electronic components due to condensation.

Condensate may form in the device when it has been transported from a cool environment to a warmer environment.

- ▶ After installing the device, wait for at least 6 h. Only then connect the device to the mains/power line.



NOTICE! Improper door sealing due to ice

Humidity inside the device causes ice formation. Ice causes damage to the seals of the inner and outer doors.

1. Dry the interior, inner doors or inner lids as well as outer doors or outer lids and all seals of the device.
 2. Switch on the device afterwards.
-

Installation

CryoCube® F101h
English (EN)

4.5.1 Enabling the back-up circuit

The back-up circuit is battery-powered. In the event of a mains/power outage, the battery will supply power to the control panel and the alarm for 72 hours.

Tools and auxiliary equipment

- Key for the switch locking plate

Prerequisites

- The device has been installed and connected according to the operating manual.

1. Unlock the switch locking plate and remove the cover.
2. Switch on the battery switch.

The back-up circuit is activated.

- An alarm is triggered in the event of a mains/power outage.
- In the event of a mains/power outage, power will still be supplied to the control panel.
- The software settings are saved in the event of a mains/power outage.
- The battery is charged with mains power. The battery is fully charged after approx. 24 hours.

3. Fit the cover and lock it.

4.5.2 Switching the device on at the mains/power switch

Tools and auxiliary equipment

- Key for the switch locking plate

Prerequisites

- The device has been installed and connected according to the operating manual.
- The device has been acclimatized for at least 6 h.
- The interior, seals, doors and lids are dry.

1. Unlock the switch locking plate and remove the cover.
2. Switch on the mains/power switch.
 - The display shows the software version number.
 - The compressor starts running after a short time delay.

3. Fit the cover and lock it.

4.6 Basic device settings

To commission the device, set the following values. Further settings are described in the Software chapter.

1. Set the desired temperature for the interior of the device.
2. Set the temperature offset.
3. Set alarm limits.
4. Set a delay time for the alarm.
5. Check the alarms.

5 Operation

5.1 Opening the outer door

Prerequisites

- The outer door is not locked.
- Pressure compensation has finished.

1. Unlock the cylinder lock, where applicable.
2. Pull the door handle forwards.
The outer door is unlocked.

5.2 Loading the device



CAUTION! Risk of crushing the hand when closing the inner door

- ▶ Do not place your fingers between the device and the inner door.



NOTICE! Longer pull-down time because the device is loaded too early

The pull-down time is the time needed for the device to cool the interior from the ambient temperature to the set temperature.

If you load the device during the cooling phase, the pull-down time will be longer. The pull-down time specified in the technical data cannot be achieved.

1. Allow the device to cool down from ambient temperature to the set temperature.
2. Place the samples in the device after the device has reached the set temperature.



The interior temperature of the device increases when loading it:

- Outer and inner doors are open.
- The sample temperature differs from the interior temperature.

- ▶ To minimize the temperature increase in the interior, load the device step by step.

Prerequisites

- Racks and accessories have been placed in the compartments.
- Device, racks and accessories have reached the set temperature.

1. Open the outer door.
2. Open the inner door of the compartment in which you want to place the samples.
3. Place the samples in the device.

Information on the maximum carrying capacity of the inner shelves can be found in the technical data.

4. Close the inner door.
5. Close the outer door.

5.3 Locking the outer door



CAUTION! Risk of crushing the hand when closing the outer door

- ▶ Do not place your fingers between the device and the outer door.
- ▶ Proceed slowly and carefully when locking the door handle.

1. Push the door handle to the back.
2. Close the outer door.
3. Lock the outer door. To do so, allow the door handle to engage.
Automatic pressure compensation takes place as soon as the outer door is closed.
4. Check if the door handle is engaged in locked position.

5.4 Pressure compensation

If you leave the outer door open for a while, the temperature in the interior will increase. After closing the outer door, the air in the interior will cool down and the atmospheric pressure will decrease. Negative pressure may occur in the device. If negative pressure occurs, the outer door can no longer be opened.

Pressure compensation takes place automatically to reestablish ambient pressure in the device. Pressure compensation takes 1 – 2 hours. Pressure compensation starts as soon as the outer door is closed.

1. To speed up pressure compensation, press the *auto vent* valve.
With the *auto vent* valve, pressure compensation takes up to 1 min.

5.5 Switching off the device



WARNING! Electric shock due to damage to the device or mains/power cord.

- ▶ Only switch on the device if the device and mains/power cord are undamaged.
- ▶ Only operate devices which have been installed or repaired properly.
- ▶ In case of danger, disconnect the device from the mains/power supply voltage. Disconnect the mains/power plug from the device or the earth/grounded socket. Use the isolating device intended for this purpose (e.g. the emergency switch in the laboratory).

5.5.1 Disabling the back-up circuit

Tools and auxiliary equipment

- Key for the switch locking plate

1. Unlock the switch locking plate and remove the cover.
2. Switch off the battery switch.

The back-up circuit is disabled.

- No alarm is triggered in the event of a mains/power outage.
- During a mains/power outage, there will be no power supply to the control panel.
- The battery is not charged.

5.5.2 Disconnecting the device from the voltage supply

Tools and auxiliary equipment

- Key for the switch locking plate

1. Unlock the switch locking plate and remove the cover.
2. Switch off the battery switch.

The back-up circuit is disabled.

- No alarm is triggered in the event of a mains/power outage.
- During a mains/power outage, there will be no power supply to the control panel.
- The battery is not charged.

3. Switch off the mains/power switch.

6 Software

6.1 Overview of the control panel

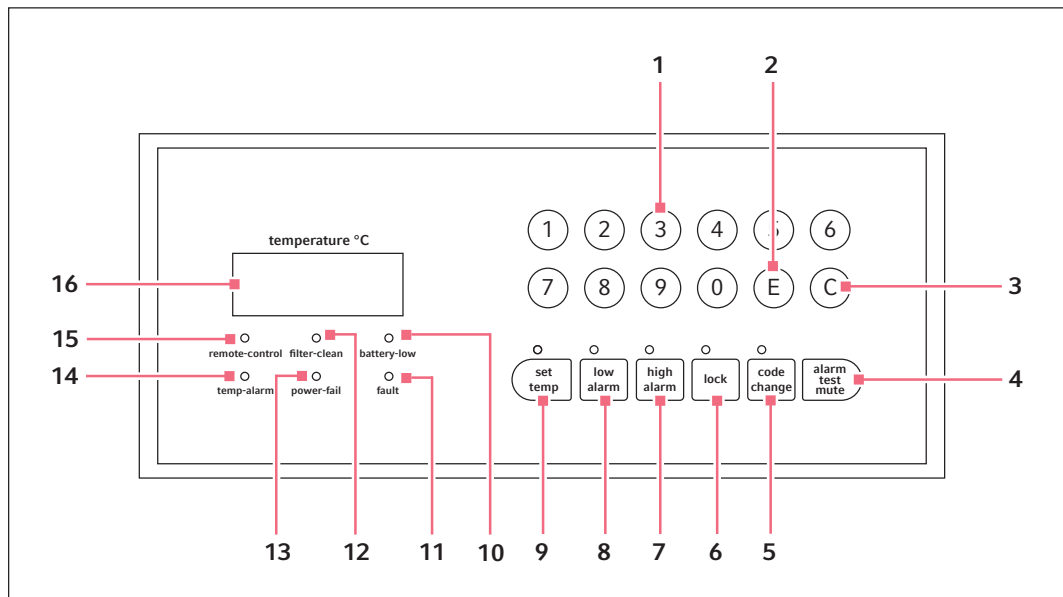

Fig. 6-1: Control panel

- | | |
|--|--|
| <p>1 Numerical keys
0 – 9</p> <p>2 E key
Used to enter data</p> <p>3 C key
Used to delete data</p> <p>4 Alarm test/mute key
Sounds the audible alarm.
Mutes the audible alarm if an alarm condition occurs.</p> <p>5 Code change key
Changes the lock code for the device</p> <p>6 Lock key
Locks and unlocks the control panel for programming</p> <p>7 Button for the alarm if the temperature is too high
The LED lights up as soon as the set temperature value is exceeded.</p> <p>8 Button for the alarm if the temperature is too low
The LED lights up as soon as the set temperature value is undercut.</p> | <p>9 Temperature setting key
Changes the temperature setting</p> <p>10 Rechargeable battery low
LED lights up: Rechargeable battery low</p> <p>11 Error
LED lights up: The device has a system error.</p> <p>12 Filter cleaning
LED lights up: blocked or contaminated filter</p> <p>13 Mains/power outage
LED flashes: Set value is exceeded or undercut</p> <p>14 Temperature alarm
Set value is exceeded or undercut</p> <p>15 Remote control
LED lights up: Device is being remotely controlled via RS-485 and laboratory data collection software.</p> <p>16 Temperature
displays the current freezing temperature in steps of 1 °C</p> |
|--|--|

6.2 Checking parameters

6.2.1 Displaying the set temperature for the interior of the device

- ▶ Press the **set temp** softkey.

The set temperature for the interior of the device is displayed.
The factory setting is -80 °C.

6.2.2 Displaying the offset for the interior temperature

- ▶ Press the **C** softkey.

The display shows the offset for the interior temperature.

6.2.3 Displaying the alarm limits for the interior temperature

- ▶ To display the alarm limit for the maximum interior temperature, press the **high alarm** softkey.
- ▶ To display the alarm limit for the minimum interior temperature, press the **low alarm** softkey.
The display shows the alarm limit.

6.2.4 Displaying the alarm delay time

- ▶ To display the delay time for the on-site alarm, press the **8** softkey.
- ▶ To display the delay time for the remote alarm, press the **9** softkey.
The delay time is displayed.

6.2.5 Displaying the ambient temperature

- ▶ Press the **0** softkey.

The ambient temperature is displayed.

6.3 Working with a lock code

To prevent unauthorized programming of the device, you can use a four-digit lock code.

6.3.1 Unlocking and locking the device

Unlocking the device

Prerequisites

- The lock code is activated.

1. Press the **lock** softkey.

If the **lock** indicator light flashes, a lock code has been set.

2. Enter the lock code.

The actual temperature is displayed.

The **lock** indicator light glows. The device is in programming mode. The parameters can be changed.

Locking the device

Prerequisites

- The lock code is activated.

3. After programming is completed, press the **lock** softkey.

The **lock** indicator light goes out. The device is no longer in programming mode. The parameters are saved.



If you press a softkey, e.g., **set temp**, while the **lock** indicator light is flashing, ---- appears on the display. The control panel is locked.

6.3.2 Activating and changing the lock code



NOTICE! No software access due to lost lock code

If you lose the lock code, reprogramming of the device will no longer be possible. The lock code will have to be reset by an authorized service technician.

- ▶ Keep the lock code in a safe place.

In the factory setting, the lock code is deactivated. To activate or change the lock code, proceed as follows.

1. Press the **lock** softkey.
2. When the **lock** indicator light flashes, enter the lock code.
The **lock** indicator light glows. The device is in programming mode. The parameters can be changed.
3. Press the **code change** softkey.
The **code change** indicator light flashes. The display is empty.
4. Enter a lock code using the numerical keys.
The lock code is displayed.
5. Check the lock code on the display.
6. To delete the entry, press softkey **C**.
7. Confirm the entry. To do so, press softkey **E**.
The **code change** indicator light goes out.
The new lock code is active.
8. Exit programming mode. To do so, press the **lock** softkey.
The **lock** indicator light goes out. The device is no longer in programming mode. The parameters are saved.

6.3.3 Deactivating the lock code

To deactivate the lock code, set it to **0000**.

1. Press the **lock** softkey.
The **lock** indicator light flashes.
2. Enter the current lock code.
The actual temperature is displayed.
The **lock** indicator light glows. The device is in programming mode. The parameters can be changed.
3. Press the **code change** softkey.
The **code change** indicator light flashes. The display is empty.
4. Enter the lock code **0000** using the numerical keys.
Entering the lock code **0000** will deactivate the lock code.
The lock code *0000* is displayed.
5. Check the lock code on the display.
6. To delete the entry, press softkey **C**.
7. Confirm the entry. To do so, press softkey **E**.
The **code change** indicator light goes out.
The new lock code is deactivated.
8. Exit programming mode. To do so, press the **lock** softkey.
The **lock** indicator light goes out. The device is no longer in programming mode. The parameters are saved.

6.4 Programming parameters

6.4.1 Setting the set temperature value for the interior

You can set the set temperature for the interior of the device to a range from -50 °C to -86 °C.

Prerequisites

- The device is not protected by a lock code.

1. Press the **lock** softkey.
The **lock** indicator light lights up. The device is in programming mode. The parameters can be changed.
2. Press the **set temp** softkey.
The **set temp** indicator light flashes. *0* is displayed.
3. Enter the set temperature with the numerical keys.
The set temperature is displayed. The set temperature is automatically displayed as a negative value.
4. To delete the entry, press the **C** softkey.
5. Confirm the entry. To do so, press the **E** softkey.
The **set temp** indicator light goes out.
6. Exit programming mode. To do so, press the **lock** softkey.
The **lock** indicator light goes out. The parameters are saved.

6.4.2 Setting an offset for the set temperature in the interior

You can set an offset of 0 °C to -5 °C for the set temperature value in the interior. The offset is added to the set temperature. The device temperature cannot fall below -86 °C.

Prerequisites

- The device is not protected by a lock code.

1. Press the **lock** softkey.
The **lock** indicator light lights up. The device is in programming mode. The parameters can be changed.
2. Press the **C** softkey.
3. Enter the offset using the numerical keys.
The offset is displayed.
To deactivate the offset, enter the value 0.
4. To delete the entry, press the **C** softkey.
5. Confirm the entry. To do so, press the **E** softkey.
6. Exit programming mode. To do so, press the **lock** softkey.
The **lock** indicator light goes out. The parameters are saved.

6.4.3 Setting alarm limits

You can set alarm limits for the interior temperature. If the interior temperature exceeds an alarm limit, an alarm will be triggered.

	Minimum value	Maximum value
Alarm limit for the minimum temperature in the interior	-91 °C	5 °C below the set temperature
Alarm limit for the maximum temperature in the interior	5 °C above the set temperature	-10 °C

Prerequisites

- The device is not protected by a lock code.

1. Press the **lock** softkey.
The **lock** indicator light lights up. The device is in programming mode. The parameters can be changed.
2. To set the alarm limit for the maximum interior temperature, press the **high alarm** softkey.
The **high alarm** indicator light flashes. The display shows 0.
3. To set the alarm limit for the minimum interior temperature, press the **low alarm** softkey.
The **low alarm** indicator light flashes. 0 is displayed.
4. Enter the alarm limit using the numerical keys.
The display shows the alarm limit.
5. To delete the entry, press the **C** softkey.
6. Confirm the entry. To do so, press the **E** softkey.
The **high alarm** indicator light goes out.

7. Exit programming mode. To do so, press the **lock** softkey.
The **lock** indicator light goes out. The parameters are saved.

6.4.4 Setting an alarm delay time

You can set a delay time for the "Interior temperature too high" and "Interior temperature too low" alarms. The delay time can be set for the on-site alarm and the remote alarm.

	Minimum value	Maximum value	Factory setting
On-site alarm	0 min	40 min	30 min
Remote alarm	0 min	40 min	30 min

If you set the delay time to 0 min, the delay time will automatically be set to 15 s.

Prerequisites

- The device is not protected by a lock code.

1. Press the **lock** softkey.
The **lock** indicator light lights up. The device is in programming mode. The parameters can be changed.
2. To set the delay for the on-site alarm, press the **8** softkey.
3. To set the delay for the remote alarm, press the **9** softkey.
PP is displayed.
4. Enter the delay time using the numerical keys.
The delay time is displayed.
5. To delete the entry, press the **C** softkey.
6. Confirm the entry. To do so, press the **E** softkey.
--- is displayed. The value is saved.
7. If the entered value is outside the limit values, *EE* is displayed. Repeat the entry.
8. Exit programming mode. To do so, press the **lock** softkey.
The **lock** indicator light goes out. The parameters are saved.

7 Maintenance

7.1 Service schedule

Service	Service cycle
Defrost the device.	As required
Clean the interior and exterior of the device.	As required
Clean the seals.	Once a month
Clean the air filter and the air intake grille.	Every 3 months under normal ambient conditions. Clean more frequently if the surroundings are very dusty or dirty.

7.2 Defrosting the device



CAUTION! Risk of slipping due to melt water

Puddles may form on the laboratory floor when defrosting the device.

- ▶ Wipe up melt water immediately.



NOTICE! Risk of device damage due to scraping off ice

Removing ice with a sharp object may damage the device.

- ▶ Wait until the ice has thawed by itself.



NOTICE! Improper door sealing due to ice

Humidity inside the device causes ice formation. Ice causes damage to the seals of the inner and outer doors.

1. Dry the interior, the inner and outer doors and all device seals.
2. Switch on the device afterwards.

Tools and auxiliary equipment

- Personal protective equipment: Cold protection gloves, protective goggles, dust protection mask
- Material for absorbing the melt water
- "Defrosting device" notice sign

Prerequisites

- The samples have been transferred to another ULT freezer.
- The device has been switched off and disconnected from the mains/power line(see p. 30).

1. Put up the notice sign.
2. Open the outer and inner doors.
3. Wait until the ice has thawed.
4. Wipe up the melt water.
5. Dry the interior, the inner and outer doors and all device seals.

7.3 Cleaning and decontamination



DANGER! Electric shock.

- ▶ Switch off the device and disconnect the mains/power plug before commencing any service or cleaning operations.
-



NOTICE! Damage from the use of aggressive chemicals.

- ▶ Do not use any aggressive chemicals on the device or its accessories, such as strong and weak bases, strong acids, acetone, formaldehyde, halogenated hydrocarbons or phenol.
 - ▶ If the device has been contaminated by aggressive chemicals, clean it immediately using a mild cleaning agent.
-

7.3.1 Cleaning the device

Tools and auxiliary equipment

- Water
- Mild cleaning agent
- Soft, lint-free cloth

Prerequisites

- For cleaning the interior: The device has been switched off and disconnected from the mains/power line.
- The device is defrosted.

1. Moisten the lint-free cloth with water and cleaning agent.
2. Clean the surfaces.

7.3.2 Cleaning and disinfecting the control panel

Tools and auxiliary equipment

- Laboratory cleaner
- Lint-free cloth
- Disinfectant: Ethanol 70%, sodium hypochlorite solution 1%, Dismozon pur, Hexaquart S, Biozid ZF or another suitable disinfectant

1. To lock the control panel, press the **lock** softkey.
2. Moisten the lint-free cloth with laboratory cleaner or disinfectant.
3. Wipe the control panel with the cloth.
4. Unlock the locked control panel.

7.3.3 Removing the inner door

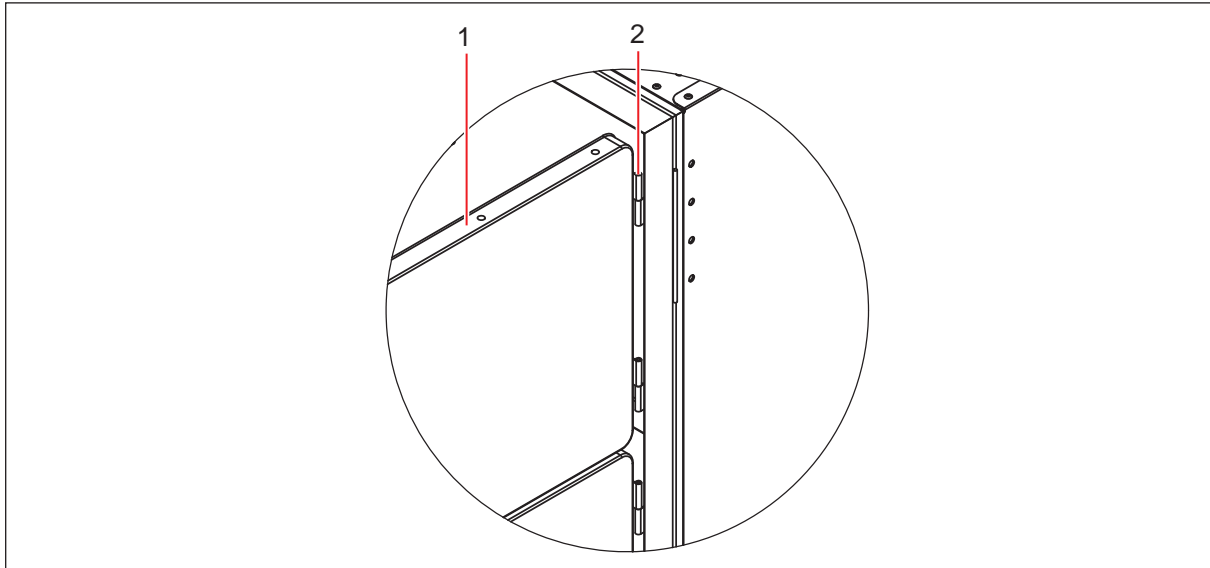

Fig. 7-1: Lifting out the inner door

1 Inner door

2 Lift-off hinge

1. Fully open the outer door of the freezer.
2. Fully open the inner door.
3. Lift the inner door out of the hinges and carefully set it aside.
4. Clean the inner door.

7.3.4 Installing the inner door again

1. Fully open the outer door of the freezer.
2. Fit the inner door on the hinge pins and close it.
3. Check that the inner door seal sits firmly around the edge of the freezer.
4. Close the outer door.

7.3.5 Cleaning the seals

Tools and auxiliary equipment

- Dry soft lint-free cloth

1. Wipe the seal with a soft, lint-free cloth.
2. Wipe the surface on which the seal rests with a soft, lint-free cloth.

7.3.6 Cleaning the air filter and the air intake grille



NOTICE! Refrigeration failure due to blocked air filter

If the air filter is blocked, the refrigerant will not be liquefied. This will damage the compressor.

- ▶ Regularly check that the air flow into the device is not obstructed.
-

Tools and auxiliary equipment

- Vacuum cleaner
- Warm water

1. Loosen the rotary knobs on the air intake grille.
The air intake grille folds down.
2. Remove the air intake grille.
3. Clean the air intake grille with a vacuum cleaner or alternatively with a soft brush.
4. Remove the coarse dirt from the air filter by vacuuming or tapping it.
5. Clean the air filter with warm water.
6. Let the air filter dry.
7. Insert the air filter.
8. Insert the air intake grille and fold it upwards. Tighten the rotary knobs.

7.3.7 Decontaminating the interior

The interior is made of stainless steel.

Tools and auxiliary equipment

- Decontamination agent consisting of 70 % isopropyl alcohol and 30 % distilled water
- Soft, lint-free cloth

Prerequisites

- The device has been switched off and disconnected from the mains/power line.
- The device is defrosted.

1. Moisten the lint-free cloth with decontamination agent.
2. Clean the surfaces using a lint-free cloth.
The surfaces are coated with a decontamination agent.
3. Allow the decontamination agent to take effect.
4. Wipe off the decontamination agent with deionized water.
5. Allow the surfaces to dry.

7.4 Checking the alarm

7.4.1 Checking indicator lights and the signal tone

- ▶ Press the **alarm test/mute** softkey.

As long as the **alarm test/mute** softkey is pressed, all indicator lights are lit. The signal tone sounds.
The display shows 8888.

7.4.2 Checking the alarm in the case of a mains/power outage

Prerequisites

- The back-up circuit is activated.

- ▶ Switch off the device using the mains/power switch.

The **power fail** indicator light lights up.

The display shows the interior temperature and flashes at intervals of 10 s.

The signal tone sounds on the device.

If the device is connected to a building management system via the remote alarm interface, the alarm is forwarded to the building management system.

7.5 Safety checklist

1. Fill in the safety checklist prior to repair or service of the device.
2. Hand a copy of the safety checklist to the authorized service technician.



1. Freezer contents Yes No
 Risk of infection Yes No
 Risk of toxicity Yes No
 Risk from radioactive sources Yes No

(List all potentially hazardous materials that have been stored in this unit.)
 Notes:

2. Contamination of the unit:
 Unit interior Yes No
 No contamination Yes No
 Decontaminated Yes No
 Contaminated Yes No
 Others

3. Instructions for safe repair/maintenance of the unit:
 a) The unit is safe to work on Yes No
 b) There is some danger (see below) Yes No
 Procedure to be adhered to in order to reduce safety risk indicated in b) below.

Date :
 Signature :
 Address, Division :
 Telephone :

Product name :
 Model :
 Serial number :
 Date of installation :

Please decontaminate the unit yourself before calling the service engineer.

8 Troubleshooting

8.1 General errors

If your freezer is experiencing a problem, first check the following troubleshooting advices before contacting your authorized Eppendorf service technician.

Symptom/message	Possible cause	Solution
Door does not open	<ol style="list-style-type: none"> 1. The door handle is locked. 2. The heated ventilation nozzle is clogged. 	<ol style="list-style-type: none"> 1. Unlock the door handle. 2. Use the plunger to break the ice in the ventilation nozzle. <p>If the door will not open:</p> <ul style="list-style-type: none"> ▶ Contact the Eppendorf customer service.
LED FILTER CLEAN is illuminated	<ul style="list-style-type: none"> • Filter is clogged. 	<ul style="list-style-type: none"> ▶ Clean the filter (see <i>Cleaning the air filter and the air intake grille on p. 42</i>). <p>If the LED continues to be illuminated:</p> <ul style="list-style-type: none"> ▶ Contact the Eppendorf customer service.

8.2 Error messages

Your electronically controlled freezer is equipped with the unique self-diagnostics software "Systems Monitoring And Reporting Technology" (S.M.A.R.T. Plus™) for the self-diagnosis of faults in electronic systems, probes and/or the cooling system.

The following table lists and explains the error codes that may appear on the control panel display:

Symptom/message	Possible cause	Solution
E -01	<ul style="list-style-type: none"> • Fault on PT100 probe 1. This probe is located in the interior of the freezer and monitors the interior temperature. 	<ul style="list-style-type: none"> ▶ Please contact the Eppendorf customer service.
E -02	<ul style="list-style-type: none"> • Fault on probe 2. This probe monitors the cascade condenser. 	<ul style="list-style-type: none"> ▶ Please contact the Eppendorf customer service.
E -03	<ul style="list-style-type: none"> • This probe monitors the air-cooled condenser. 	<ul style="list-style-type: none"> ▶ Please contact the Eppendorf customer service.

Symptom/ message	Possible cause	Solution
E -04	<p>Air-cooled condenser temperature is too high:</p> <ol style="list-style-type: none"> 1. The filter may be clogged. 2. The ambient temperature may be too high. <p>If the alarm persists:</p> <ul style="list-style-type: none"> • The fan may have broken down. 	<ol style="list-style-type: none"> 1. Clean the filter in accordance with the instructions (see <i>Cleaning the air filter and the air intake grille on p. 42</i>). 2. Reduce the temperature in the room. <p>► Please contact the Eppendorf customer service.</p>

8.3 After a mains/power failure

If mains/power is interrupted, the **POWER-FAIL** indicator will illuminate. In addition, the audible alarm will sound and the display will flash at approximately 10-second intervals.

When mains/power is restored, both alarm and indicator will automatically be cancelled.

If mains/power has been interrupted for only a short time, the internal temperature of the freezer will not have risen above the temperature setpoint (the user-set alarm threshold), so normal operation will be resumed immediately.

If the interruption was long enough for the internal temperature to rise above the temperature setpoint, the **TEMP-ALARM** indicator will illuminate. If the internal temperature does not fall below the temperature setpoint within the programmed time after mains/power was restored, the audible alarm will sound again. The TEMP-ALARM indicator will extinguish when the internal temperature reaches the High Alarm temperature set point.

8.4 Heating up of the interior

Leaving the door open long enough for the inside temperature to rise above the set temperature will have the same consequences as a power failure (see above).

To minimize the risk that this will happen, the door should only be opened when needed and only as brief as possible.

The freezers have internal doors to minimize the temperature increase when the outer door is open.

9 Transport, storage and disposal

9.1 Decommissioning

Tools and auxiliary equipment

- Adhesive tape

Prerequisites

- Racks and samples have been transferred to another ULT freezer.
1. Disable the back-up circuit (see p. 31).
 2. Disconnect the device from the voltage supply (see p. 25).
 3. Remove the safety clamp of the mains/power cord. Remove the mains/power cord from the device.
 4. Defrost the device.
 5. Decontaminate the device.

9.2 Transport



NOTICE! Risk of device damage due to lifting the device without the original pallet

Lifting the device without the original pallet will damage the base of the device.

1. Place the device on the original pallet.
2. Secure the device.
3. Use a transport aid to lift the device.



NOTICE! Damage to the compressor and refrigeration cycle during transport

Tilting the device or transporting it in a horizontal position will damage the compressors and the refrigeration cycle. Refrigerant and oil may leak out. Shocks may dislodge the compressors from the brackets.

- ▶ Transport the device in upright position.
- ▶ Move the device with due caution and care. Do not knock the device into anything.
- ▶ Protect the device from impacts.
- ▶ After setting up the device, wait for 6 h before switching it on.



NOTICE! Damage to electronic components due to condensation.

Condensate may form in the device when it has been transported from a cool environment to a warmer environment.

- ▶ After installing the device, wait for at least 6 h. Only then connect the device to the mains/power line.



NOTICE! Damage to the door handle due to too high loads

Pulling or pushing the device on the door handle during transport may damage the door handle.

- ▶ Grip the device at the housing to pull or push it.
-

Transport, storage and disposal

CryoCube® F101h

English (EN)

9.2.1 Preparing the device for transport

Tools and auxiliary equipment

- Open-end wrench
- Adhesive tape

Prerequisites

- Racks and samples have been transferred to another ULT freezer.

1. Disable the back-up circuit (see p. 30).
2. Disconnect the device from the voltage supply (see p. 31).
3. Remove the safety clamp of the mains/power cord. Remove the mains/power cord from the device.

9.2.2 Transporting the device

Personal protective equipment

- Protective clothing, safety shoes

Tools and auxiliary equipment

- Transport aid
- Original pallet

General transport

1. Transport the device in an upright position.
2. Grasp the device by the housing and place it at its new location.

Do not grasp the device at the door handle.

Lifting the device

3. Place the device on the original pallet and secure it.
4. Lift the device with a transport aid.



If you need help to transport the device, contact the authorized service.

9.3 Shipment

9.3.1 Shipping regulations

ULT freezers have the UN number 3358 (Refrigerating machines, containing flammable, non-toxic, liquefied gas) and are subject to the relevant regulations. ULT freezers which contain less than 100 g of flammable refrigerant are exempt from these regulations.

All other ULT freezers can be declared non-hazardous goods. These ULT freezers can be shipped by air, by sea and by land.

9.3.2 Shipping the device



WARNING! Risk of personal injury due to contamination.

If a contaminated device is stored or shipped, people can become contaminated.

- ▶ Clean and decontaminate the device before shipping or storing.



NOTICE! Risk of damage due to incorrect packing.

Eppendorf AG is not liable for damage caused by improper packing.

- ▶ Only store and transport the device in its original packaging.
 - ▶ If you no longer have the original packaging, it can be requested from Eppendorf AG.
-

Prerequisites

- The device has been decommissioned (see p. 30).
- The device has been cleaned and decontaminated.
- The original packaging is available.

1. Download the "Decontamination declaration for product returns" from the www.eppendorf.com website.
2. Fill out the decontamination certificate.
3. Package the device.
4. Put the decontamination certificate into the packaging.
5. Ship the device according to the shipment regulations.



For service and repairs, send the device to Eppendorf AG or to an authorized service partner.

9.4 Disposal

If the product needs to be disposed of, the relevant legal regulations must be observed.

Information on the disposal of electrical and electronic devices in the European Community:

Within the European Community, the disposal of electrical devices is regulated by national regulations based on EU Directive 2012/19/EU pertaining to waste electrical and electronic equipment (WEEE).

According to these regulations, any devices supplied after August 13, 2005, in the business-to-business sphere, to which this product is assigned, may no longer be disposed of in municipal or domestic waste. To document this, they have been marked with the following marking:



Do not dispose of batteries together with domestic waste. Dispose of batteries in accordance with local, legal regulations.

Because disposal regulations may differ from one country to another within the EU, please contact your supplier if necessary.

10 Technical data

10.1 Power supply

Mains/power supply voltage	230 V
Mains/power frequency	50 Hz
Current consumption	5 A
Power consumption The device is empty. The interior temperature is -80 °C. The ambient temperature is 20 °C.	6.3 kWh/day
Electromagnetic compatibility (EMC)	The device meets the following requirements: <ul style="list-style-type: none"> • IEC/EN 61326-1 • EN 55011 (CISPR 11)
Overvoltage category	II
Degree of pollution	2

10.2 Ambient conditions

10.2.1 Operation

Ambience	For indoor use only
Ambient temperature	10 °C – 32 °C
Relative humidity	Maximum 80 %, non-condensing
Atmospheric pressure	80 kPa – 106 kPa

10.2.2 Storage

	Air temperature	Relative humidity	Atmospheric pressure
Without transport packaging	-20 °C – 35 °C	10 % – 91 %	70 kPa – 106 kPa

10.3 Dimensions

10.3.1 External dimensions

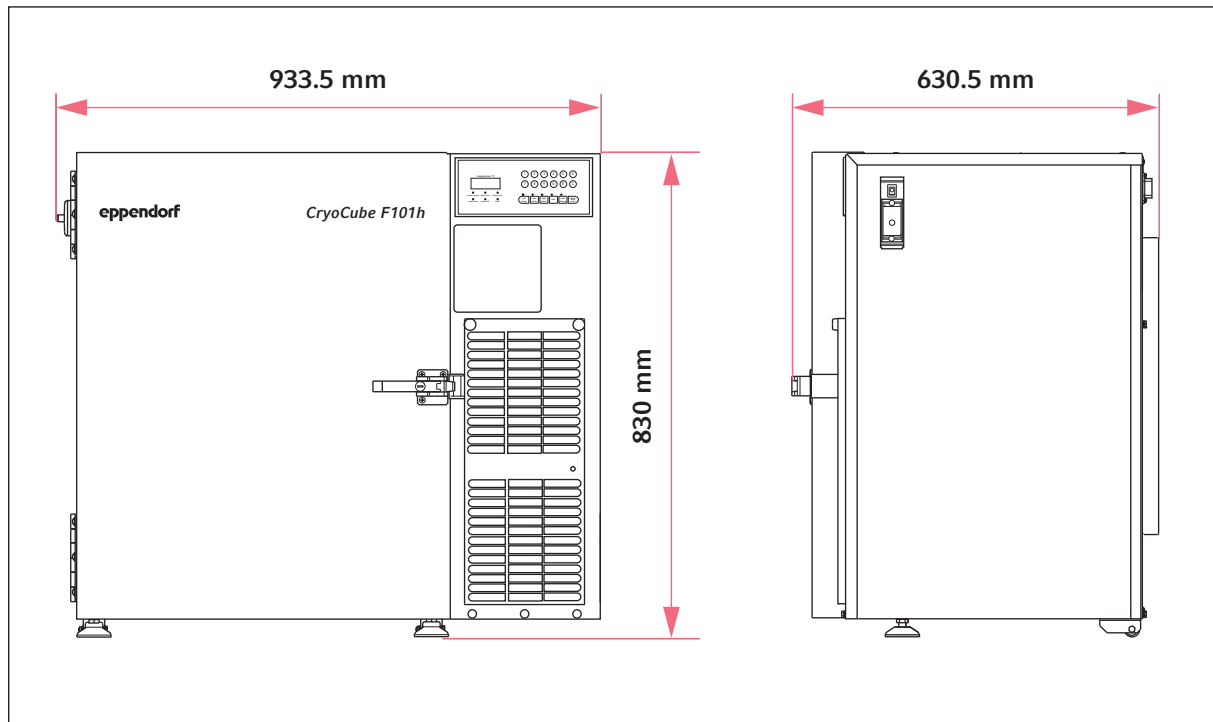

10.3.2 Internal dimensions

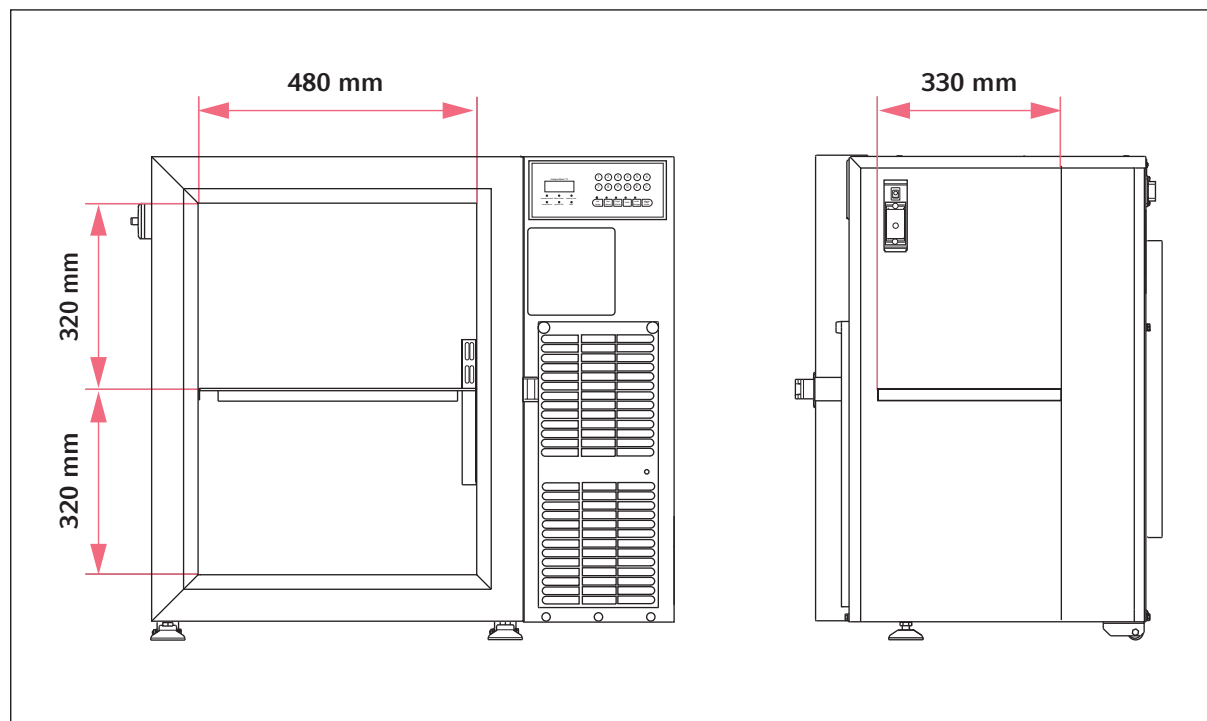

10.3.3 Packing dimensions

Width	1142 mm
Depth	773 mm
Height	1055 mm

10.4 Weight

Device	123 kg
Packaged device	152 kg

10.5 Noise level

Noise level	52.8 dB (A)
-------------	-------------

10.6 Interfaces

BMS	Remote alarm, 24 V, 1 A
Serial interface	RS-485

Only connect devices to the interfaces that comply with the IEC 60950 (UL 60590) standards.

10.7 Temperature control

10.7.1 Temperature range

Setting range	-50 °C to -86 °C
---------------	------------------

10.7.2 Times for cooling and heating the interior

Pull down time from 20 °C to -80 °C (freezer empty)	140 min
Warm up time from -80 °C to 0 °C (freezer 2/3 full)	18 h

10.7.3 Cooling of the refrigeration cycle

Cooling	Air cooling
---------	-------------

10.7.4 Refrigerant

Refrigeration cycle 1	Refrigeration cycle 2
R-290 (78 g)	R-170 (65 g)
Refrigerant	Components
R-170	Ethane
R-290	Propane

10.8 Additional specifications

10.8.1 Capacity and carrying capacity

Capacity	101 L
Shelf	1
Racks per compartment	3

10.8.2 Materials

Outer door insulation	Polyurethane foam
Device insulation	Vacuum insulation panels Polyurethane foam
Interior	Stainless steel (304 2B)

11 Ordering information

11.1 Accessories

11.1.1 Back-up systems

Order no. (International)	Description
	CO2 back-up system
F652999005	100 V/50 Hz - 60 Hz
U9043-0002	120 V - 220 V/60 Hz
U9043-0004	230 V/50 Hz
	LN2 back-up system
F652999006	100 V/50 Hz - 60 Hz
U9044-0002	120 V - 220 V/60 Hz
U9044-0004	230 V/ 50 Hz

11.1.2 Chart recorder

Order no. (International)	Description
	Chart recorder type 2
	Connection to mains/power supply in the ULT freezer
F652999001	100 V/120 V, 50 Hz – 60 Hz
F652999002	208 V – 230 V, 50 Hz – 60 Hz
	Discs for chart recorder type 2
	-100 °C – 0 °C
F625999003	60 pieces

11.1.3 Racks

Order no. (International)	Description
	Rack with drawers
	material stainless steel
6001 062.210	drawer height 53 mm
6001 062.910	drawer height 64 mm
6001 062.310	drawer height 76 mm
6001 062.410	drawer height 102 mm
6001 062.510	drawer height 127 mm
	Rack with side access
	material stainless steel
6001 061.210	drawer height 53 mm
6001 061.910	drawer height 64 mm
6001 061.310	drawer height 76 mm
6001 061.410	drawer height 102 mm
6001 061.510	drawer height 127 mm

Ordering informationCryoCube® F101h
English (EN)**11.1.4 Cardboard boxes and box dividers**

Order no. (International)	Description
B50-SQ B75-SQ B95-SQ	Cardboard box width 133 mm, depth 133 mm, height 50 mm width 133 mm, depth 133 mm, height 75 mm width 133 mm, depth 133 mm, height 100 mm
D49 D64 D81 D100	Box divider for 7 × 7 vessels, maximum vessel diameter 17.4 mm for 8 × 8 vessels, maximum vessel diameter 15 mm for 9 × 9 vessels, maximum vessel diameter 13 mm for 10 × 10 vessels, maximum vessel diameter 11.8 mm

11.1.5 Eppendorf Storage Boxes

Order no. (International)	Description
0030 140.508	Eppendorf Storage Box 10 × 10, 2 inch height 52.8 mm, for 100 cryogenic tubes with internal thread 3 pieces
0030 140.516	Eppendorf Storage Box 9 × 9, 2 inch height 52.8 mm, for 81 screw cap (cryogenic) tubes 1 mL - 2 mL 3 pieces
0030 140.524	Eppendorf Storage Box 8 × 8, 2 inch height 52.8 mm, for 64 micro test tubes 1 mL - 2 mL 3 pieces
0030 140.532	Eppendorf Storage Box 8 × 8, 2.5 inch height 63.5 mm, for 25 micro test tubes 5 mL 4 pieces
0030 140.540	Eppendorf Storage Box 9 × 9, 3 inch height 76.2 mm, for 81 screw cap (cryogenic) tubes 3 mL 2 pieces
0030 140.567	Eppendorf Storage Box 9 × 9, 4 inch height 101.6 mm, for 81 screw cap (cryogenic) tubes 4 mL - 5 mL 2 pieces
0030 140.583	Eppendorf Storage Box 5 × 5, 5 inch height 127 mm, for 25 conical tubes 15 mL 2 pieces
0030 140.591	Eppendorf Storage Box 3 × 3, 5 inch height 127 mm, for 9 conical tubes 50 mL and 4 conical tubes 15 mL 2 pieces
0030 140.613	Eppendorf Storage Box 5 × 5, 3 inch height 76.2 mm, for 25 screw cap tubes 5 mL 2 pieces

11.1.6 VisioNize system

Further information about the Eppendorf VisioNize system can be found on the www.eppendorf.com webpage. Contact your local Eppendorf partner for more information.

Index**A**

Alarm20

B

Battery switch

Switching off30

Switching on28

D

Degree of pollution.....51

Device

Switching off31

Switching on28

Disposal50

E

Electromagnetic compatibility (EMC)51

Error codes45

M

Mains/power failure46

Mains/power supply51

N

Noise level53

R

Rise in temperature46

S

S.M.A.R.T. Plus45

Setpoint, temperature.....46

Storage51, 51

Switching off

Back-up circuit.....30

Battery switch30

Device	31
Switching on	
Back-up circuit.....	28
Battery switch	28
Device	28
T	
Technical data	
Ambient conditions.....	51
Noise level.....	53
Technical data	
Mains/power supply.....	51
Temp alarm.....	46
Temperature setpoint	46
Troubleshooting	45
W	
Warming.....	46
Weight	53

Index

CryoCube® F101h
English (EN)

Evaluate Your Manual

Give us your feedback.
www.eppendorf.com/manualfeedback