

Esco Frontier® Duo™ Laboratory Fume Hood,
Model EFD-4B_
(Shown with optional base cabinet)

Frontier® DUO™

General Purpose Laboratory Fume Hoods

Introduction

The Esco Frontier® Duo™ Fume Hood offers a solution representing design and engineering innovations that are at the forefront of fume hood technology. It provides superior containment of noxious chemical fumes at a face velocity of 0.5 m/s while addressing worker comfort through improved ergonomic design. Work zone baffles and aerodynamic airfoil were designed with Computational Fluid Dynamics (CFD) for enhanced safety, improved airflow uniformity and reduction in noise levels.

Superstructure

- Rugged dual-wall construction allows service fixtures to be remotely-controlled and electrical outlets to be mounted outside the work zone within easy reach.
- Main body is constructed of electrogalvanized steel (zinc coated to prevent rusting even if the powder coat is abraded, and phosphated for better adhesion of the powder coating).
- It has Isocide™ powder coating for chemical abrasion and weathering resistance.
- State-of-the-art baffle system constructed of phenolic resin laminate delivers maximum containment by ensuring airflow uniformity throughout the main chamber.
- Corrosion-resistant epoxy powder-coated electrogalvanized steel airfoil safely ventilates fumes generated towards the front of the hood for superior operator protection.
- Has a vertical-rising sash constructed of tempered laminated glass with fail-safe counterbalanced mechanism. The safety mechanism causes sash to tilt and lock if a cable snaps.
- Dished work top provides spill retention and is constructed of phenolic resin, a highly corrosion-resistant material.
- Standard service fixtures include 1 water fixture and 1 gas fixture.
- 2 electrical outlets are provided in every hood (total rating: 5 A).

Aesthetics and Ergonomics Design

- Perfect Pitch Profile - The gentle pitch of the hood enhances visibility and enables users to work further into the hood without strain.
- The 8° sloped sash allows users to lean forward with minimal glare and reflections.
- Complementary color scheme (neutral white with blue accents) blends the hood with any casework, metal or wood.
- Energy-efficient hood lighting through a pre wired, electronic ballast. Typical light intensity on work surface is >900 lux in zero ambient conditions.
- Color temperature is tuned to provide a gentle and comfortable work environment for the user.

Serviceability

- Removable front panel enables easy access to lighting and other electrical components mounted above the hood work chamber.

Safety Certified and Tested

All Esco fume hoods are manufactured for the most demanding laboratory applications.

- Independently tested and certified by Invent, UK to meet the requirements of the ANSI/ASHRAE 110-1995 Standard.
- Sash is clearly labeled with all operating instructions and illustrations.

Accessories and Options

Esco offers a variety of options and accessories to meet application requirements.

- Additional service fixtures and electrical outlets (specify Amperes required) can be installed.
- Fully configurable optional Esco Sentinel™ Silver Microprocessor controller provides a continuous display of face velocity. The alarm system is triggered once the face velocity within the work zone falls to a low level that compromises operator safety.
- Optional motorized sash window for improved operator convenience.
- Base cabinetry is available for additional storage area in the laboratory.
- Optional distillation grids can be ordered separately for factory installation.

Guide to Models

EFD - 4 - A - 8

External Width	Code	Controller	Code	Electrical	Code
1200 mm (47.2")	4	Rocker Switches	A	220-240 VAC, 50/60 Hz, 1Ø	8
1500 mm (59.0")	5	Sentinel™ Silver Microprocessor Control System	B	110-120 VAC, 50/60 Hz, 1Ø	9
1800 mm (70.9")	6				
2400 mm (94.5")	8				

General Specifications, Frontier® Duo™ Fume Hoods

Model	220-240 VAC, 50/60 Hz, 1Ø	EFD-4A8 2090098	EFD-4B8 2090105	EFD-5A8 2090311	EFD-5B8 2090114	EFD-6A8 2090120	EFD-6B8 2090312	EFD-8A8 2090128	EFD-8B8 2090132	
	110-120 VAC, 50/60 Hz, 1Ø	EFD-4A9 2090097	EFD-4B9 2090103	EFD-5A9 2090109	EFD-5B9 2090113	EFD-6A9 2090119	EFD-6B9 2090124	EFD-8A9 2090524	EFD-8B9 2090523	
Nominal size	1.2 meter (4')		1.5 meter (5')		1.8 meter (6')		2.4 meters (8')			
External Dimensions (W x D x H)	1200 x 793 x 1500 mm (47.2" x 31.2" x 59.0")		1500 x 793 x 1500 mm (59.0" x 31.2" x 59.0")		1800 x 793 x 1500 mm (70.9" x 31.2" x 59.0")		2400 x 793 x 1500 mm (94.5" x 31.2" x 59.0")			
Internal Work Area, Dimensions (W x D x H)	1000 x 592 x 1259 mm (39.4" x 23.3" x 49.6")		1300 x 592 x 1259 mm (51.2" x 23.3" x 49.6")		1600 x 592 x 1259 mm (63" x 23.3" x 49.6")		2200 x 592 x 1259 mm (86.6" x 23.3" x 49.6")			
Exhaust Volume/ Static Pressure Required Face Velocity of 0.5 m/s (100 fpm) at Full Open Sash	1296 cmh at 70 Pa 763 cfm at 0.28" WG		1400 cmh at 75 Pa 824 cfm at 0.30" WG		1543 cmh at 86 Pa 908 cfm at 0.34" WG		2372 cmh at 80 Pa 1396 cfm at 0.32" WG			
Exhaust Outlet Diameter	305 mm (12")									
Number of Exhaust Collars	1		1		1		2			
Fluorescent Light Intensity	970 lux (90 foot-candles)		955 lux (89 foot-candles)		915 lux (85 foot-candles)		968 lux (90 foot-candles)			
Construction	Main Body EG steel with oven-baked Epoxy-polyester hybrid Isocide™ powder coating									
	Internal Liner & Baffle System Esco Resinate phenolic resin laminates									
	Work Top Phenolic Resin									
Sash Specification	Sash Material Tempered Laminated and Framed Sash Glass									
	Sash Configuration Vertical									
	Sloping 8° slope									
	Maximum Sash Opening 550 mm (21.7")									
Power Consumption	25 W (Fluorescent Lighting Only) / 60 W (Fluorescent Lighting and Microprocessor Control System)									
Electrical*	Cabinet Full Load Amps (FLA)		7 A	6 A	7 A	6 A	7 A	6 A	7 A	6 A
	Cabinet BTU/Hr**		205	341	341	341	341	341	410	341
Net Weight***	157 Kg (346 lbs)		181 Kg (399 lbs)		205 Kg (452 lbs)		283 Kg (624 lbs)			
Shipping Weight***	212 Kg (467 lbs)		243 Kg (536 lbs)		287 Kg (633 lbs)		294 Kg (648 lbs)			
Shipping Dimensions, Maximum*** (W x D x H)	1300 x 950 x 1940 mm (51.2" x 37.4" x 76.4")		1600 x 950 x 1940 mm (63.0" x 37.4" x 76.4")		1950 x 950 x 1940 mm (76.8" x 37.4" x 76.4")		2500 x 950 x 1940 mm (98.4" x 37.4" x 76.4")			

*The maximum rating of all the electrical outlets combined is 5 Amp. Please contact Esco if you need electrical outlets with higher capacity.

**Cabinet BTU = Cabinet nominal power x 3.41214

***Fume hood unit only. Excludes base cabinet/ optional stand.

General Specifications, Base Cabinet for Frontier® Duo™ Fume Hoods

Model	EBD-4A0 2090044	EBD-5A0 2090045	EBD-6A0 2090046	EBD-8A0 2090048
Nominal size	1.2 meter (4')	1.5 meter (5')	1.8 meter (6')	2.4 meters (8')
External Dimensions (W x D x H)	1200 x 770 x 860 mm (47.2" x 30.3" x 33.9")	1500 x 770 x 860 mm (59.0" x 30.3" x 33.9")	1800 x 770 x 860 mm (70.9" x 30.3" x 33.9")	2400 x 770 x 860 mm (94.5" x 30.3" x 33.9")
Net Weight	76 Kg (168 lbs)	82 Kg (181 lbs)	98 Kg (216 lbs)	136 Kg (300 lbs)
Shipping Weight	109 Kg (240 lbs)	145 Kg (320 lbs)	207 Kg (456 lbs)	236 Kg (520 lbs)
Shipping Dimensions, Maximum (W x D x H)	1350 x 750 x 1100 mm (53.1" x 29.5" x 43.3")	1600 x 750 x 1100 mm (63.0" x 29.5" x 43.3")	1950 x 750 x 1100 mm (76.8" x 29.5" x 43.3")	2500 x 780 x 1100 mm (98.4" x 30.7" x 43.3")

Model EFD (B-Series) Frontier® Duo™ Fume Hood Engineering Drawing

Top View (for EFD-4, EFD-5, EFD-6)

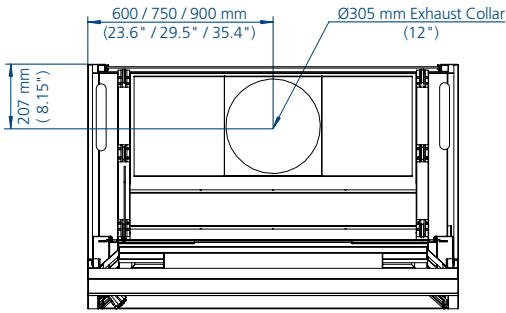

Top View (for EFD-8)

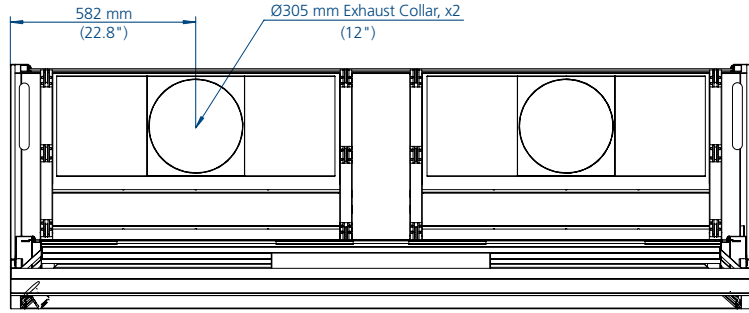

Front View

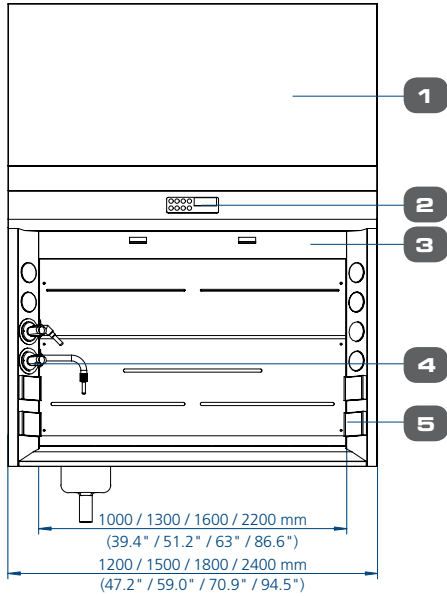

Side View

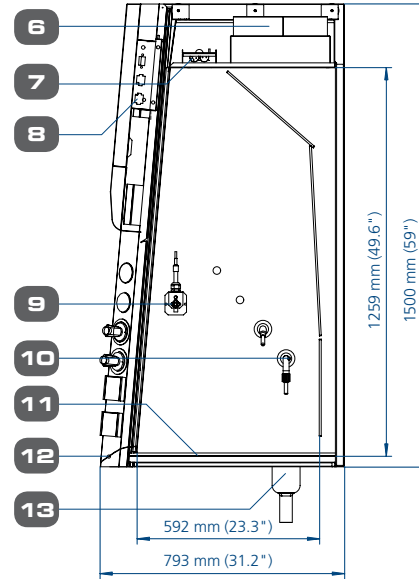

- 1. Removable Front Panel
- 2. Sentinel™ Silver Microprocessor Control System/ Rocker Switches
- 3. Sash Window
- 4. Service Fixture Remote Control

- 5. Electrical Outlet
- 6. Exhaust Collar
- 7. Fluorescent Lamp
- 8. Electrical Panel
- 9. Airflow Sensor (optional)

- 10. Service Fixture Outlet
- 11. WorkTop
- 12. Ergonomic Airfoil
- 13. Drip Cup

Model EBD Base Cabinet for Frontier® Duo™ Fume Hood Engineering Drawing

Top View

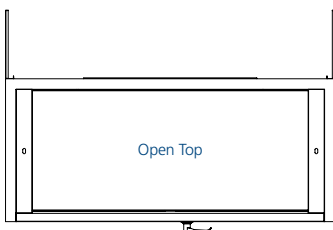

Rear View

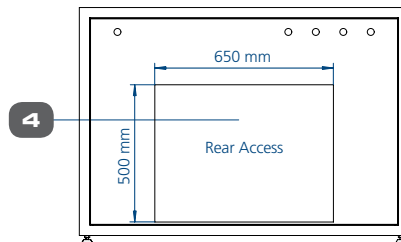

Front View

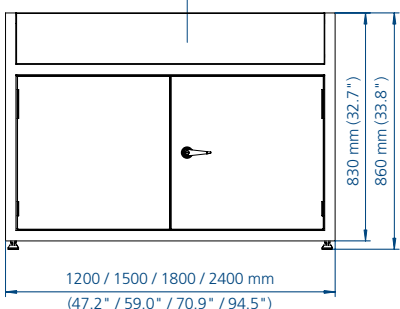

Side View

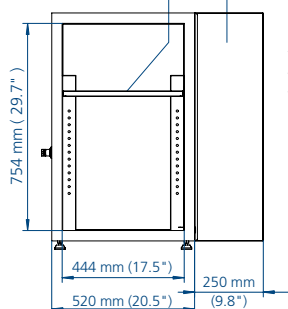

- 1. Removable Front Panel
- 2. Adjustable Shelf
- 3. Side Filler Panel
- 4. Rear Access for plumbing

Fume Hood Installation Requirements

- Proper location (refer to Esco recommendations)
- Exhaust system capable of delivering airflow and pressure drop requirements
 - Exhaust ductwork and connection accessories
 - Exhaust blower (or building exhaust system)
 - Contractor (if applicable)
 - Means of adjusting exhaust flow (damper or frequency inverter)
- Sufficient laboratory supply air
- Base cabinet or other means of support
- Plumbing and electrical hook-up
- Unless otherwise specified, items and services specified above are not provided by Esco

ESCO GLOBAL NETWORK



- ART Equipment
- Biological Safety Cabinets
- CO₂ Incubators
- Compounding Pharmacy Equipment
- Containment / Pharma Products
- Ductless Fume Hoods
- Freeze Dryer
- Lab Animal Research Products
- Laboratory Fume Hoods
- Laboratory Ovens and Incubators
- Laminar Flow Clean Benches
- PCR Cabinets
- PCR Thermal Cyclers
- Powder Weighing Balance Enclosures
- Ultra-low Freezers

The Esco Group of Companies is a global life sciences tools provider with sales in over 100 countries. The group is active in lab equipment, pharma equipment and medical devices. Manufacturing facilities are located in Asia and Europe. R&D is conducted worldwide spanning the US, Europe and Asia. Sales, service and marketing subsidiaries are located in 12 major markets including the US, UK, Singapore, Japan, China and India. Regional distribution centers are located in the US, UK, and Singapore.

Life Science • Chemical Research • Assisted Reproductive Technology (ART) • Pharmaceutical Equipment • General Equipment

ESCO

WORLD CLASS. WORLDWIDE.

Esco Micro Pte. Ltd. • 21 Changi South Street 1 • Singapore 486 777
 Tel +65 6542 0833 • Fax +65 6542 6920 • mail@escoglobal.com
 www.escoglobal.com

Esco Technologies, Inc. • 903 Sheehy Drive, Suite F, Horsham, PA 19044, USA
 Toll-Free USA and Canada 1-877-479-3726 • Tel 215-441-9661 • Fax 484-698-7757
 eti.sales@escoglobal.com • www.escolifesciences.us

Esco Global Offices: Sydney, Australia | Manama, Bahrain | Beijing, China | Chengdu, China | Guangzhou, China | Shanghai, China
 Kowloon, Hong Kong | Bangalore, India | Delhi, India | Mumbai, India | Jakarta, Indonesia | Rome, Italy | Osaka, Japan
 Kuala Lumpur, Malaysia | Melaka, Malaysia | Manila, Philippines | Moscow, Russia | Singapore | Midrand, South Africa
 Seoul, South Korea | Bangkok, Thailand | Barnsley, United Kingdom | South Yorkshire, United Kingdom | Philadelphia, PA, USA | Hanoi, Vietnam