



Fisherbrand CO₂ Incubators

50153099 May 2017

© 2017 Thermo Fisher Scientific. All rights reserved.

This Instruction Manual is copyright protected. Rights resulting thereof, particularly reprint, photomechanical or digital post-processing or reproduction, even in part, are only allowed with the written consent of Thermo Fisher Scientific.

This regulation does not apply to reproductions for in-plant use.

The contents of this document are subject to change without notice. Concerning translations into foreign languages, the English version of these operating instructions is binding.

Trademarks

All trademarks are the property of Thermo Fisher Scientific and its subsidiaries unless otherwise specified.

Trademarks used are owned as indicated at fishersci.com/trademarks.

Thermo Fisher Scientific

300 Industry Drive

Pittsburgh, Pennsylvania 15275

United States

Thermo Fisher Scientific provides this document to its customers with a product purchase to use in the product operation. This document is copyright protected. This document is copyright protected and any reproduction of the whole or any part of this document is strictly prohibited, except with the written authorization of Thermo Fisher Scientific.

The content of this document are subject to change without notice.

All technical information in this document is for reference purposes only. System configurations and specifications in this document supersede all previous information received by the purchaser.

Contents

Chapter 1 General notes	1
Overview of the Thermo Fisher international sales organizations	1
Identification of the device and of the documentation	2
Instruction of the operating personnel	2
Applicability of the instructions	2
Warranty	3
Explanation of safety information and symbols.....	4
Safety information and symbols used in the operating instructions	4
Additional symbols for safety informations:	4
Symbols on the device	5
Intended purpose of the device.....	6
Correct use	6
Incorrect use	6
Standards and directives.....	7
Safety notes on gases.....	7
Safety notes on carbon dioxide (CO ₂)	8
Chapter 2 Delivery of the device	9
Packaging.....	9
Acceptance inspection.....	9
Standard equipment components	10
Chapter 3 Installation of the device	11
Ambient conditions	11
Room ventilation.....	12
Space requirements.....	13
Transport	14
Stacking	14
Retrofitting/Modifications	16
Chapter 4 Description of the device	17
Front view of the Fisherbrand CO ₂ incubator	17
Rear view Fisherbrand CO ₂ incubator	19
Safety devices.....	20
Work space atmosphere	21
Door switch.....	22
Sensor system	23
Supply interface	24
Work space components.....	26
Interior container	26
Water reservoir	27
Heating system	27
Rear panel openings	28
Shelf system	29
Water pump	30

Chapter 5 Start-up	33
Let the device adapt to the ambient conditions	33
Preparing the work space	33
Installing the shelf system	33
Installation/removal of the support rail	34
Installing the shelf supports:	35
Levelling the device	35
Gas connection	36
Installing gas pressure hoses	36
Gas connection	37
Power supply connection	38
Connecting the RS 232 interface.....	39
Connecting the alarm contact.....	39
Chapter 6 Operation	43
Preparing the device.....	43
Starting operation.....	44
Chapter 7 Handling and control (touchscreen controller)	45
Power switch	45
Operating panel and operating structure	46
Factory presettings of the Touchscreen controls	49
Heat-up phase of the control loop sensors	49
Event actions for settings	50
Setting the temperature set value	51
Setting the CO ₂ set value	53
Auto-start routine	55
Activating auto start	57
Interrupting the auto-start routine	59
Running the 90°C routine	60
User configuration	60
Settings	61
Options	69
Icon description	74
Enabling/disabling the keypad lock	76
Software versions	77
Error messages	78
Response to an error message event	78
Resetting the overtemperature protection mechanism	79
Troubleshooting	80
Chapter 8 Shut-down	83
Shutting the device down.....	83
Chapter 9 Cleaning and disinfection	85
Cleaning	85
Decontamination procedures.....	85

Wipe/spray disinfection	86
90°C decontamination routine	89
Activating the 90°C routine	92
Interrupting the 90°C routine	94
90°C routine interruption due to error	95
Completing the 90°C routine	96
Chapter 10 Maintenance	97
Inspections and checks	97
Service intervals	97
Preparing the temperature calibration	98
Temperature calibration procedure	100
Preparing the CO ₂ calibration	102
CO ₂ calibration procedure	104
Replacing the gas inlet filter	106
Replacing the device fuses	107
Replacing the door seal	108
Chapter 11 Disposal	109
Chapter 12 Technical data	111
Chapter 13 Device log	113

Figures

Figure 1. Device dimensions.....	13
Figure 2. Lift points.....	14
Figure 3. Stacking	15
Figure 4. Front view Fisherbrand CO ₂ incubator.....	17
Figure 5. Rear view Fisherbrand CO ₂ incubator.....	19
Figure 6. Looped-through gas supply Fisherbrand CO ₂ incubator.....	20
Figure 7. Door switch.....	22
Figure 8. Temperature, CO ₂ sensors.....	23
Figure 9. Supply interface.....	24
Figure 10. Work space components.....	26
Figure 11. Water reservoir.....	27
Figure 12. Rear panel openings.....	28
Figure 13. Shelf system	29
Figure 14. Water pump.....	30
Figure 15. Support rail installation/removal.....	34
Figure 16. Shelf support installation.....	35
Figure 17. Installing gas pressure hoses.....	36
Figure 18. Gas connection.....	37
Figure 19. Power supply connection.....	38
Figure 20. Connection example	41
Figure 21. Power switch.....	45
Figure 22. Pressure-sensitive areas.....	46
Figure 23. Touchscreen	47
Figure 24. Menu structure overview.....	48
Figure 25. Heat-up phase display	49
Figure 26. Setting the temperature set value	51
Figure 27. Setting the CO ₂ set value	53
Figure 28. Activating the auto-start routine.....	57
Figure 29. Interrupting the auto-start routine	59
Figure 30. Changing the code.....	61
Figure 31. Date / time setting	63
Figure 32. Display contrast setting	64
Figure 33. Key tone setting.....	65
Figure 34. Language setting.....	66
Figure 35. Reminder interval setting.....	67
Figure 36. Error table display.....	69

Figure 37. Alarm relay setting.....	70
Figure 38. Low humidity setting.....	71
Figure 39. Water level setting.....	72
Figure 40. Alarm relay setting.....	73
Figure 41. Icon description overview.....	74
Figure 42. Enabling/disabling the keypad lock.....	76
Figure 43. Software versions.....	77
Figure 44. Event error messages.....	78
Figure 45. Event error overtemperature.....	79
Figure 46. Decontamination routine phases.....	91
Figure 47. Activating the 90°C routine.....	92
Figure 48. Interrupting / canceling 90°C.....	94
Figure 49. 90°C decontamination routine completion.....	96
Figure 50. Preparing the temperature calibration.....	99
Figure 51. Temperature calibration procedure.....	100
Figure 52. Preparing CO ₂ calibration.....	102
Figure 53. Measurement opening.....	103
Figure 54. CO ₂ calibration procedure.....	104
Figure 55. Gas inlet filter installation.....	106
Figure 56. Device fuse replacement.....	107
Figure 57. Magnetic door seal replacement.....	108

General notes

Overview of the Thermo Fisher Scientific international sales organizations

Sales enquiries from Europe:

Austria	+43 (0)800-20 88 40
Belgium	+32 (0)56 260 260
Denmark	+45 70 27 99 20
Germany	+49 (0)2304 9325
Ireland	+353 (0)1 885 5854
Italy	+39 02 950 59 478
Finland	+358 (0)9 8027 6280
France	+33 (0)3 88 67 14 14
Netherlands	+31 (0)20 487 70 00
Norway	+47 22 95 59 59
Portugal	+351 21 425 33 50
Spain	+34 902 239 303
Sweden	+46 31 352 32 00
Switzerland	+41 (0)56 618 41 11
UK	+44 (0)1509 555 500

Technical enquiries from Europe, Middle East and Africa:

Phone	+ 49 (0) 6184 / 90-6940
Fax	+ 49 (0) 6184 / 90-7474
E-Mail	info.labequipment.de@thermofisher.com

Sales enquiries from the United States:

Phone	+1 800-766 7000	for customer service
Fax	+1 800-926 1166	to fax an order
URL	fishersci.com	to order online

Technical enquiries in the United States:

Phone	+1 800-879 7767
Fax	+1 828-658 0363
URL	info.labequipment@thermofisher.com

Sales enquiries from Canada:

Phone	+1 800-234 7437	for customer service
Fax	+1 800-463 2996	to fax an order
URL	fishersci.ca	to order online

Technical enquiries in Canada:

Phone	+1 800-234-7437
Fax	+1 828-658 0363
URL	info.labequipment@thermofisher.com

Identification of the device and of the documentation

Identification of the device

Device name: Fisherbrand CO₂ Incubators

Allocation of product documentation

User information: Operating instructions 50153099

Valid: 05.2017

Certifications and quality audit:

Certification: CE Certification

Test mark: VDE-GS

C_{CSA}US

Instruction of the operating personnel

These operating instructions describe the Fisherbrand CO₂ incubator. The CO₂ incubator has been manufactured in keeping with the latest technological developments and is operationally safe. However, the device may present potential hazards, particularly if it is operated by inadequately trained personnel or if it is not used in accordance with the intended purpose. Therefore, the following must be observed to prevent accidents:

- The CO₂ incubator must be operated only by trained and authorized personnel.
- For any operation of this device, the operator must prepare clear and concise written instructions in the language of the operating and cleaning personnel based on these operating instructions, applicable safety data sheets, plant hygiene guidelines, and technical regulations, in particular:
 - which decontamination measures are to be applied for the CO₂ incubator and accessories,
 - which protective measures apply when specific agents are used,
 - which measures are to be taken in the case of an accident.
- Repairs to the device must be carried out only by trained and authorized expert personnel.

Applicability of the instructions

- The contents of the operating instructions are subject to change without further notice.
- Concerning translations into foreign languages, the German version of these operating instructions is binding.

- Keep these operating instructions close to the device so that safety instructions and important information are always accessible.

Should you encounter problems that are not detailed adequately in these operating instructions, please contact Thermo Fisher Scientific immediately for your own safety.

Warranty

Thermo Fisher Scientific warrants the operational safety and functions of the CO₂ incubator only under the condition that:

- the device is operated and serviced exclusively in accordance with its intended purpose and as described in these operating instructions,
- the device is not modified,
- only original spare parts and accessories that have been approved by Thermo Fisher Scientific are used,
- inspections and maintenance are performed at the specified intervals.

The warranty is valid from the date of delivery of the device to the operator.

Explanation of safety information and symbols

Safety information and symbols used in the operating instructions



Indicates a hazardous situation which, if not avoided, could result in minor or moderate injuries.



Indicates a hazardous situation which, if not avoided, could result in damage to equipment or property!

NOTE

Is used for applicational hints and useful information.

Additional symbols for safety informations:



Wear safety gloves!



Wear safety goggles!



Harmful liquids!



Electric shock!



Hot surfaces!



Fire hazard!



Explosion hazard!



Suffocation hazard!

Symbols on the device



CE conformity mark: confirms conformity according to EU Guidelines



VDE test mark



Mark of conformity USA/Canada



Observe operating instructions!

Intended purpose of the device

Correct use

This CO₂ incubator is designed for preparing and cultivating cell cultures, but it is not to be used for medical applications or for in-vitro-diagnostics. To that end, a controlled set of physiological ambient conditions is produced in the workspace of the device by exerting precise control of the following parameters:

- temperature,
- CO₂ content,
- and increased relative humidity.

Typically, this CO₂ incubator has been designed for installation and operation in the following areas:

- Laboratories for cytobiological and biotechnological experiments of safety levels L1, L2, and L3.
- Medical-microbiological laboratories in accordance with DIN EN 12128.
- Laboratories in the central area of clinics and hospitals.

This device is intended for professional use only and must only be operated by trained staff.

Incorrect use

Do not use cell or tissue cultures in the device that are not in accordance with the regulations of safety levels L1, L2, and L3.

Do not use tissues, substances or liquids that:

- are easily ignitable or explosive,
- release vapors that form combustible or explosive mixtures when exposed to air,
- release poisons.

Standards and directives

The device complies with the following standards and directives:

- DIN EN 61010 - 1: 2011, DIN EN 61010 - 2 - 010: 2015
- Low Voltage Directive 2014/35/EU
- EMC Directive 2014/30/EU
- China EEP Hazardous Substances Information
<http://www.thermofisher.com/us/en/home/technical-resources/rohs-certificates.html>.

The following safety regulations must be observed if the device is operated within the territory of the Federal Republic of Germany:

- DGUV Guideline 100-500
- TRBS 3145/TRGS 725
- Safety data sheets of the gas suppliers with regard to the particular characteristics of CO₂.
- Principles of good microbiological proceedings, notice of the trade association of the German chemical industry.

For other countries, the applicable national regulations are binding.

Safety notes on gases

NOTE

Installation work:

Any work to supply lines and pressurized gas containers, cylinders or containers used for storing CO₂ must only be carried out by expert personnel using the appropriate tools.

Instruction of the personnel:

Personnel operating devices with CO₂ supply must be instructed about the particularities in the handling of CO₂ before starting their work:

- **correct operation of pressurized gas containers and gas supply systems,**
- **obligation to report damages and shortcomings in CO₂ supply lines,**
- **measures to be taken in case of accidents or failures.**

These instructions must be repeated at appropriate intervals and must comprise the particular operating instructions of the gas supplier.

Safety notes on carbon dioxide (CO₂)

Since CO₂ is rated as a harmful gas, certain safety instructions must be observed when the CO₂ incubator is started up and when the device is operated.

Suffocation hazard!

Large amounts of CO₂ released into the room atmosphere may cause suffocation.



If CO₂ is released, initiate safety measures immediately!

- Leave the room immediately and do not allow others to enter the room!
- Inform security service or fire department!

Delivery of the device

Packaging

The CO₂ incubator is delivered in a stable packaging box. All packaging materials can be separated and are reusable:

- Packaging carton: Recycled paper
- Foam elements: Styrofoam (CFC-free)
- Pallet: Untreated wood
- Packaging film: Polyethylene
- Packaging ribbons: Polypropylene

Acceptance inspection

After the device has been delivered, check the delivery immediately for:

- completeness,
- possible damage.

If components are missing or damage is found on the device or the packaging, esp. damages caused by humidity and water, please contact the line-hauler as well as the Technical Support of Thermo Scientific immediately.

Standard equipment components

Quantity of the delivered components (in pieces)	Fisherbrand CO ₂ incubator
	Solid glass door and continuous shelves
Shelf	3
Support rail for shelf	4
Shelf supports for shelf	6
Insert for pressure compensation opening	1
Plug for pipe channel	1
Power supply cable	1
Connector, potential-free contact	1
Spare caps, set	1
CO ₂ connecting hose set	1
Open-end wrench, 24 mm	1
Allen wrench 2 mm for blower wheel	1
Allen wrench 3 mm for blower wheel cover	1
Operating instructions	1
Summarized Safety Instructions	1
Water pump	1

Installation of the device

Ambient conditions

The device must only be operated at locations that meet the particular ambient conditions listed below:

Requirements:

- Draft-free and dry location.
- The dust burden may not exceed the contamination category 2 based on EN 61010-1. Using the incubator in an atmosphere with electrically conductive dust is prohibited.
- The minimal distance to adjacent surfaces must be observed on all sides (see “Space requirements” on page 13).
- The operating room must be equipped with appropriate room ventilation.
- Solid, level, fire-proof surface; no flammable materials opposite to the rear panel of the incubator.
- Vibration-proof substructure (floor stand, lab table) capable of bearing the dead weight of the device and of accessories (particularly if several devices are stacked).
- The electrical system of the device has been designed for an operating height of up to 2000 m above sea level.
- To ensure a constant incubation temperature of 37 °C, the ambient temperature must be within a range of +18 °C to +33 °C.
- Relative humidity up to 80% (max.).
- No direct exposure to sunlight.
- Devices that produce excessive heat must not be placed near the location of the CO₂ incubator.
- Place the refrigerated incubator on a floor stand (option; to be ordered separately), never on the lab floor. This prevents the penetration of dust or dirt into the device.
- Power line voltage variations must not exceed ±10 % of the nominal voltage.
- Transient surges must lie within the range of levels that normally occur in the power supply system. The impulse withstand voltage based on surge category II of IEC 60364-4-443 shall be applied at the nominal voltage level.

	 WARNING	Humidity
<p>After transport or storing under humid conditions a drying-out process must be performed. During the drying-out process the equipment cannot be assumed to meet all the safety requirements of the IEC 61010-2-010 standard. The drying-out period is 2 hours.</p>		

Room ventilation

When CO₂ is supplied, the work space of the incubator is slightly pressurized. The pressure is released through the pressure compensation opening into the operating room.

Pressure compensation and any opening of the glass door/gas-tight screen during the operation of the device will release very small quantities of CO₂ into the operating room; the room ventilation must be capable of carrying the released gas safely off into the open.

In addition, heat dissipating from the device during continuous operation may cause a change in the room climate.

- Therefore, the CO₂ incubator must only be installed in rooms with sufficient ventilation.
- Do not install the device in room recesses without ventilation.
- The room ventilation should be a technical ventilation that complies with the requirements of DGUV Information 213-850 (Guidelines for laboratories, Germany) or some other suited ventilation system with appropriate capacity.

Space requirements



WARNING EMERGENCY STOP!

The mains socket must always be accessible for the case of an EMERGENCY STOP.

When installing the device, make sure that the installation and supply connections are freely accessible.

The control box on the rear panel of the device may serve as a spacer to adjacent objects. The side distances given are minimal distances.

To protect the CO₂ incubator against contamination, use a floor stand even if the device is installed near the floor. The height of the floor stand should not fall below 200 mm.

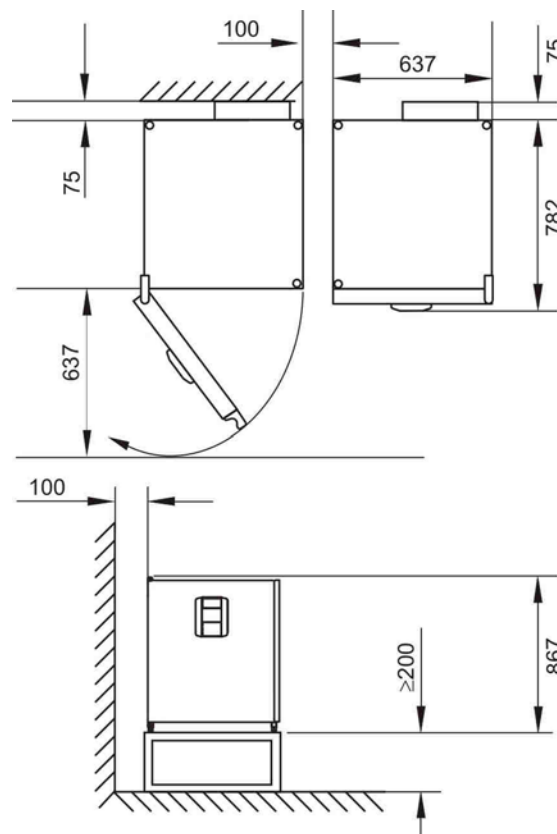

Figure 1. Device dimensions

NOTE

Accessibility of the devices:

To ensure the accessibility for care and maintenance works, keep larger side and rear distances.

Transport

For transport, do not lift the device using the doors or components attached to the device (e.g. control box on rear panel) as lift points.

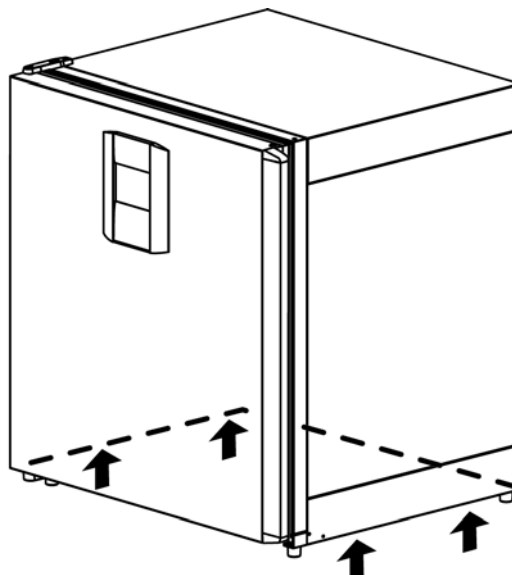



Figure 2. Lift points

NOTE

Lift points:

Lift the device only using the lift points.

	 WARNING	<p>Humidity</p> <p>After transport or storing under humid conditions a drying-out process must be performed. During the drying-out process the equipment cannot be assumed to meet all the safety requirements of the IEC 61010-2-010 standard. The drying-out period is 2 hours.</p>
--	--	--

Stacking

The CO₂ incubator is suited for stacking up to two devices of the same device type.

- Place the device to be stacked with the device stands [1] onto the stacking elements [2] at the top of the lower unit.

The devices are secured to one another by their own weight.

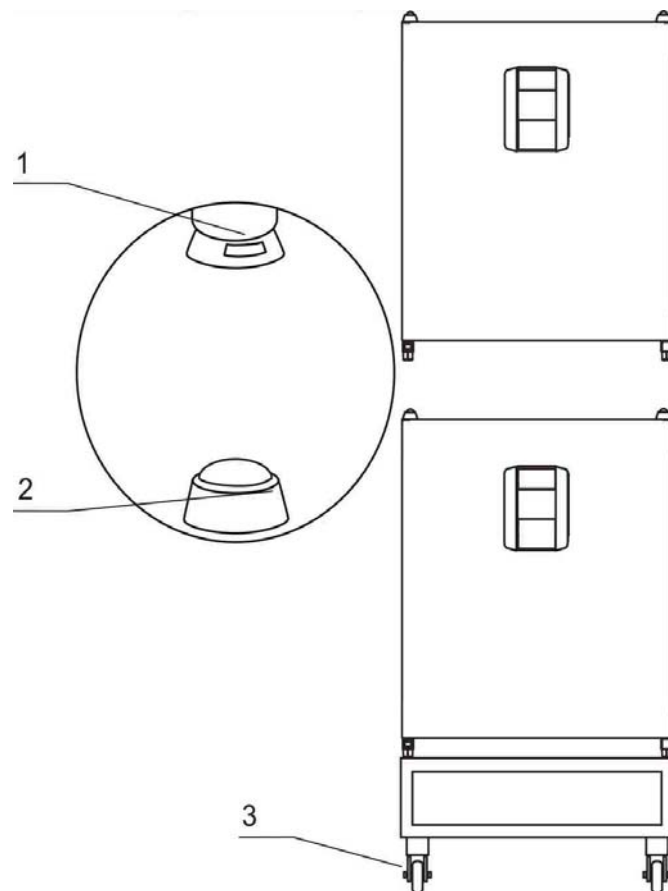

Figure 3. Stacking

NOTICE

Transporting stacked devices!

The stacking elements are not locking elements. Therefore, it is not permitted to transport stacked devices.

NOTE

Fastening on mobile racks:

If the devices are installed onto mobile racks, make sure that the rollers [3] are secured with a locking brake during the operation of the incubators and that the rollers are oriented toward the front for increased stability.

Condensate formation during the operation of stacked devices:

If stacked devices are operated at an ambient temperature of more than 26 °C, condensate formation may occur on the upper device while the 90°C decontamination routine is run for the lower device.

Retrofitting/Modifications

The following components can be retrofitted to the standard version:

- door hinge replacement on outer door and glass door (RH / LH door opening),
- infrared (IR) sensor,

NOTE

Modifications:

Retrofittings and modifications must only be performed by the Technical Service of Thermo Fisher Scientific.

Description of the device

Front view of the Fisherbrand CO₂ incubator

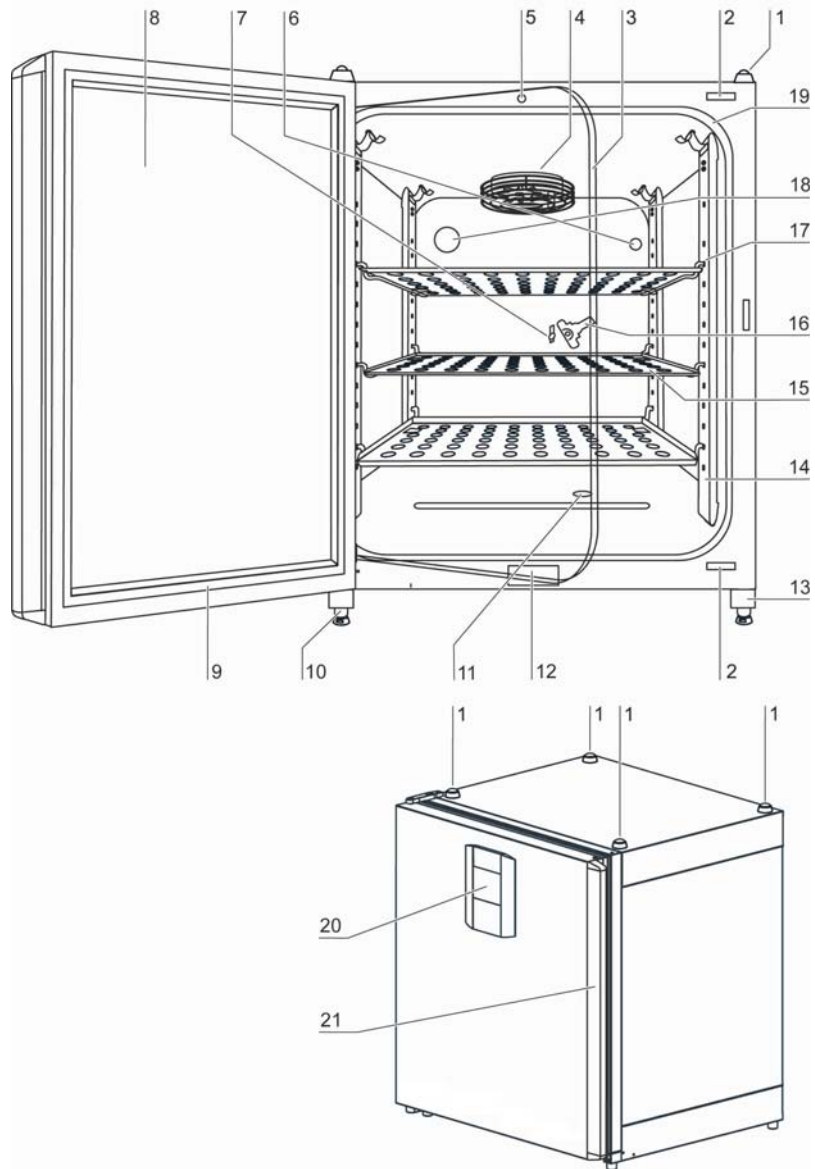

Figure 4. Front view Fisherbrand CO₂ incubator

1. Stacking elements
2. Plug caps
3. Glass door
4. Measuring cell with blower wheel and sensors
5. Door switch
6. Pressure compensation opening with insert
7. Measuring opening

8. Outer door
9. Outer door seal, replaceable
10. Stand, height-adjustable
11. Water level sensor
12. Nameplate
13. Power switch
14. Support rail
15. Shelf
16. Latch, glass door
17. Support hook for shelf
18. Access port with plug
19. Glass door seal, replaceable
20. Operating panel (touchscreen)
21. Door handle

Rear view Fisherbrand CO₂ incubator

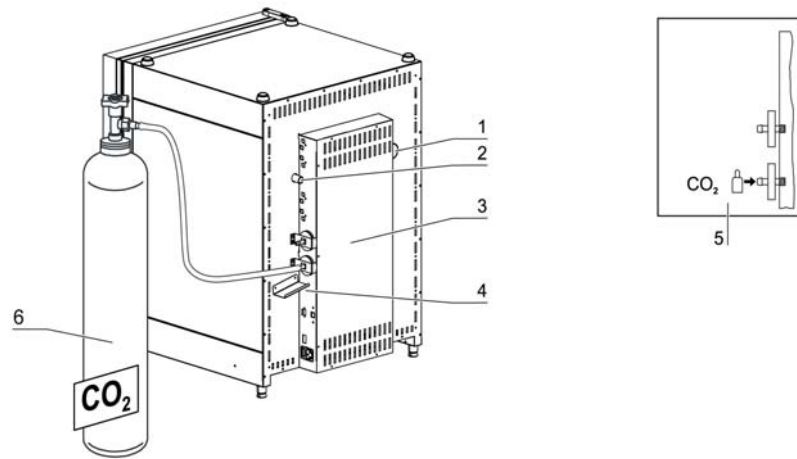

Figure 5. Rear view Fisherbrand CO₂ incubator

1. Access port, Ø 42 mm
2. Pressure compensation opening
3. Control box with supply interface for gas connection CO₂
4. Condensate drain gutter
5. Diagram: Gas connection CO₂
6. CO₂ gas cylinder

Looped-through gas supply for CO₂ incubator:

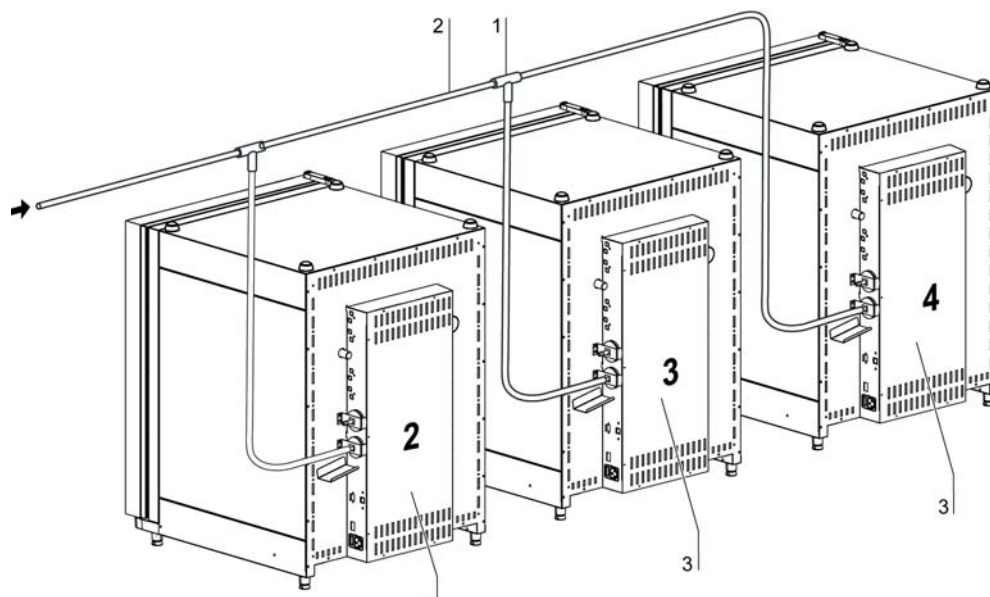

Figure 6. Looped-through gas supply Fisherbrand CO₂ incubator

1. Tee joint for fitting the gas pressure hoses together
2. Gas pressure hose for looping-through the gas supply
3. Fisherbrand CO₂ incubator with looped-through gas supply; therefore device must only be equipped with combined gas connection (optional) CO₂.

Safety devices

The device is equipped with the following safety devices:

- A door switch interrupts the CO₂ supply and the work space heating when the glass door is opened.
- The optional gas detector switches the gas supply over to a full gas cylinder.
- An independent thermal protection protects the samples from harmful overheating in case of failures.
- A pressure compensation opening ensures pressure compensation in the device work space.
- The alarm relay circuit uses audible and visual alarms to indicate errors during operation.

Work space atmosphere

In the work space of the incubator, the particular physiological ambient conditions for the preparation and cultivation of cell and tissue cultures are simulated. The work space atmosphere is determined by the following factors:

- Temperature
- Relative humidity
- CO₂ concentration

Temperature:

To ensure undisturbed operation, the temperature in the operating room must be at least 18 °C and the incubation temperature must exceed this temperature by at least 3 °C.

The heating system controls the incubation temperature from this temperature threshold up to 55 °C. The principle of air jacket heating and the additional, separate heating of the outer door and glass door/gas-tight screen minimize the risk of condensate formation at the side walls, at the ceiling of the work space, and at the glass door/gas-tight screen.

Relative humidity:

The heating of the work space promotes the condensation of the water, thereby ensuring a constant humidity within the work space. For the running operation, always keep a sufficient quantity of 3.0 l of processed water of the following quality available:

Water quality recommendation:

For trouble-free operation of the equipment, fill the water reservoir with sterilized distilled water or equivalent. The acceptable conductivity should be within the range of 1 to 20 µS (resistivity within the range of 50 kΩ to 1 MΩ).

NOTICE

Termination of warranty!

Using chlorinated tap water or additives that contain chlorine will void the manufacture warranty. Similarly, the use of ultrapure water whose conductivity is out of the range of 1 to 20 µS/cm (and whose resistivity is out of the range of 50 kΩ to 1 MΩ) will void the manufacture warranty.

If you should have any questions, please contact Technical Support of Thermo Fisher Scientific.

Under normal operating conditions and at the usual incubation temperature of 37 °C, a constant relative humidity of approx 93% is achieved in the work space.

If dew formation occurs on the culture containers due to elevated relative humidity, the humidity in the work space can be adapted to a lower value by enabling the Low Humidity feature. The relative humidity in the work space is lowered from approx. 93% to approx. 90%. The modification requires an extended adaption phase. To ensure that it effectively prevents dew formation on culture containers, it must be used as a permanent setting.

CO₂ supply:

To ensure the growth conditions for the cell and tissue cultures, the work space is supplied with CO₂.

The pH of the bicarbonate-buffered culture media largely depends on the CO₂ content of the work space atmosphere.

The CO₂ content of the work space atmosphere can be controlled within a range of 0 to 20%.

The supplied CO₂ must have one of the following quality characteristics:

- Purity 99.5% min.,
- medical gas quality.

Door switch

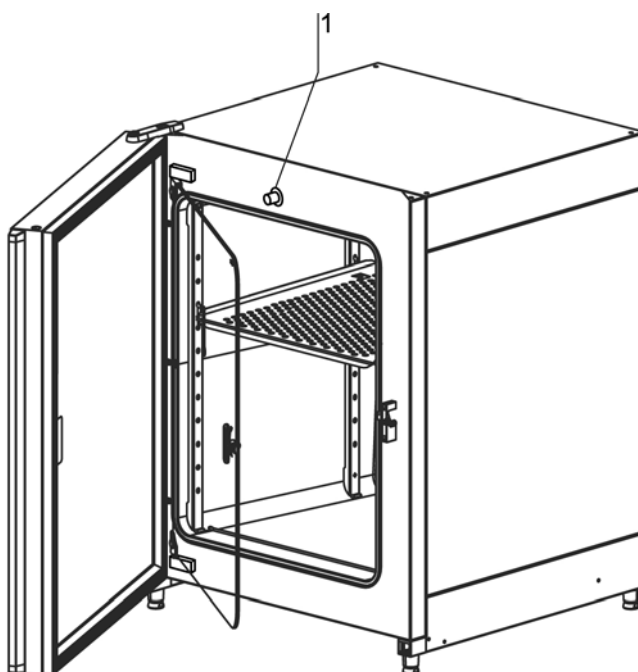

Figure 7. Door switch

A door switch [1] is installed at the upper edge of the work space opening. If the door switch is activated by opening the glass door, the gas supply and the heating of the work space are interrupted and the display shows a corresponding message.

If the door remains open for more than 30 seconds, a short audible alarm sounds. If the door remains open for more than 10 minutes, an audible alarm sounds and the alarm relay responds.

The outer door can only be closed after the glass door has been latched properly.

Sensor system

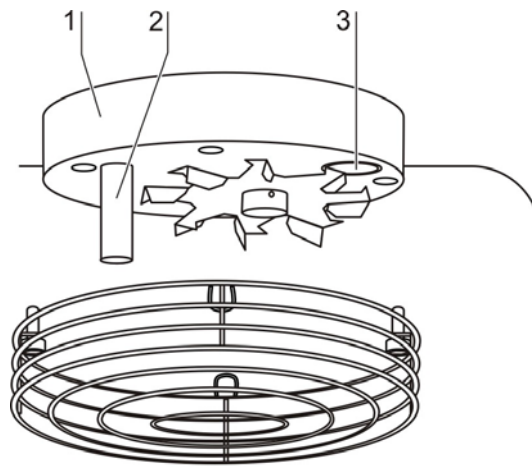

Figure 8. Temperature, CO₂ sensors

The blower wheel and two sensor modules are integral to the baseplate [1] of the measuring cell:

- Sensor [2] for the acquisition of the work space temperature and the thermal protection,
- CO₂ sensor [3] for the CO₂ acquisition of the work space

The sensor for the acquisition of the work space temperature as well as the CO₂ sensor are integral to the control system of the device. Their measured values are compared to the selected set values. Based on this data, the control system controls heating and CO₂ supply.

The blower intermixes the supplied gas and ensures an even temperature distribution within the work space.

The thermal protection has been preprogrammed at the factory and cannot be changed. It protects the stored cultures from overheating.

If the set temperature is exceeded by more than 1°C, the thermal protection responds and the work space temperature is automatically reduced to the selected set value so that the incubation process can be continued even in case of a failure. Any response of the thermal protection will simultaneously trigger a visual alarm.

If the thermal protection is enabled:

- an error message is issued,
- the alarm relay responds.

If the error message is accepted, the display shows the Overtemperature icon to indicate the response of the thermal protection, and the temperature display is highlighted in red.

Supply interface

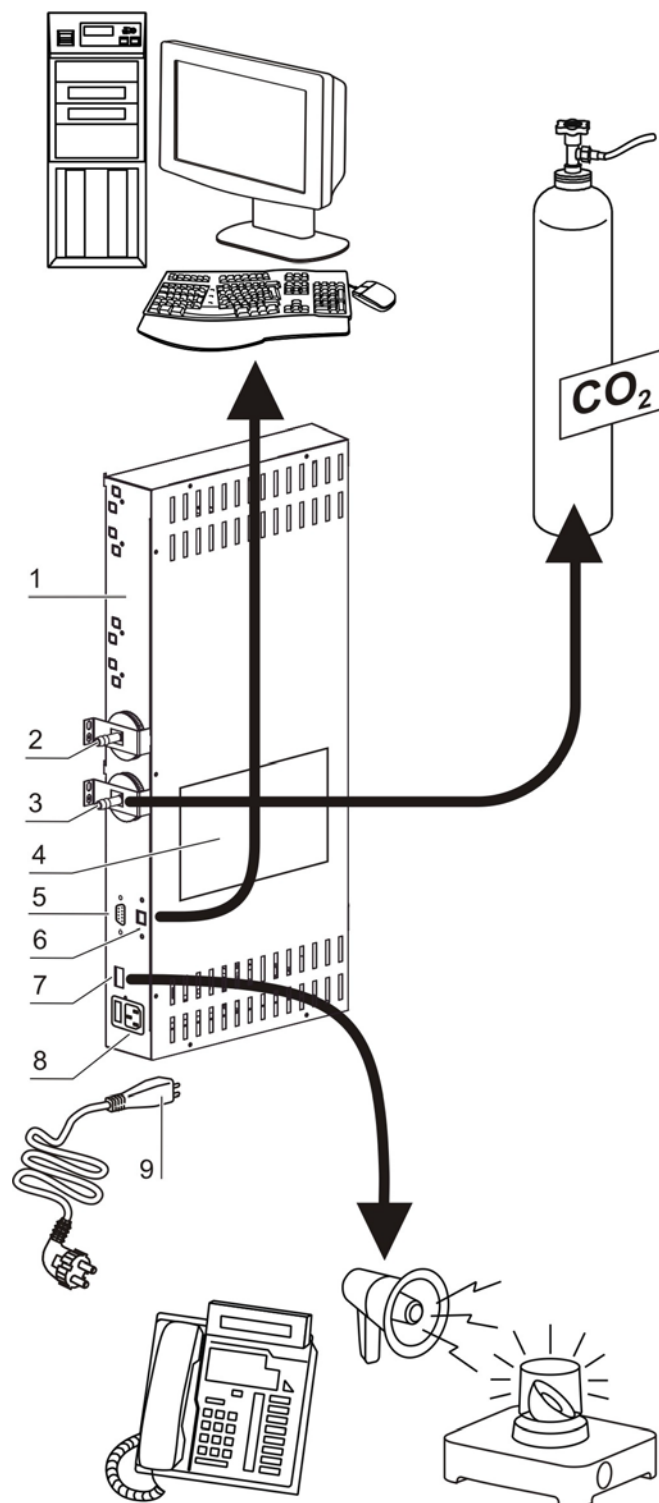

Figure 9. Supply interface

All supply connections are installed in the supply interface (control box [1]) in the rear of the device.

Gas connection:

The gas supply lines between the device and the gas supply system are connected using the supplied connecting hoses. CO₂ is connected to sleeve [3].

The process gas must be supplied to the device at a fixed pressure that has been preset within a range of 0.8 to 1.0 bar and must remain unchanged.

Before the gas is fed into the work space, they flow through a gas inlet filter with a separation rate of 99.97% for a particle size of 0.3 µm (HEPA filter quality).

Label:

The label [4] contains information about gas supply, an alarm contact terminal legend, and notes about the electrical fusing of the device.

RS 232 interface:

Via the RS 232 interface [5], the incubator can be connected to the serial interface of a PC. This connection allows the computer-aided acquisition and documentation of the major operating parameters (temperature, CO₂ concentration, error codes, etc.).

Alarm contact:

The device can be connected to an on-site, external alarm system (e.g. telephone system, building monitoring system, visual or audible alarm system).

For this purpose, a potential-free alarm contact [7] is preinstalled in the device.

NOTE**Alarm contact:**

The alarm contact responds for all errors reported by the control loops (see “Error messages” on page 78).

Power supply connection:

The connection to the power supply system is established by connecting a cable with plug for IEC connector [9] to the socket [8]. The receptacle for the two device fuses is integral to the socket.

Work space components

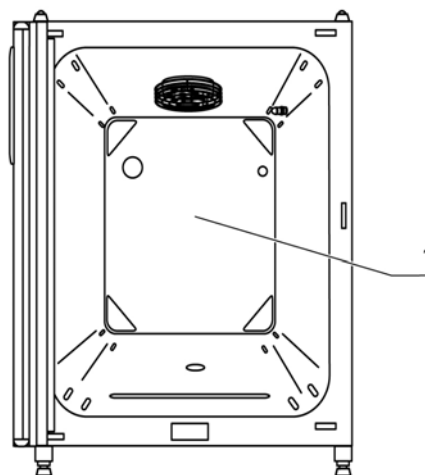

Figure 10. Work space components

The work space of the incubator has only a minimum of surface, thereby supporting both the prevention of contamination and easy, effective decontamination.

Interior container

All components of the work space are made of stainless steel and have a high-gloss polished, absolutely smooth and easy-to-clean surface. Any embossings have a large radius.

As an option, the interior container, the shelf system, and the blower wheel with its cover can be made of copper material.

Materials of the interior container

The standard version is equipped as follows:

- Interior container made from stainless steel.

Material with increased contamination protection are optionally available:

- Interior container made from stainless steel, with transparent iONGURAD™ silver ion coating,

The components of the shelf system can be removed easily so that only the easily treatable, surface-reduced interior container [1] remains in the work space for cleaning and manual disinfection works.

Water reservoir

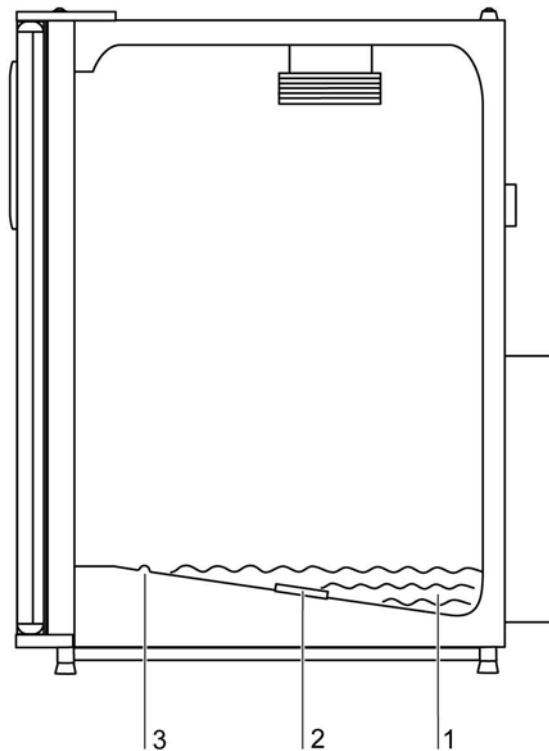

Figure 11. Water reservoir

The water reservoir [1] is integral to the interior container floor and inclines toward the rear. The water level is monitored by a water level sensor [2] that issues an alarm message at the display and an audible signal when the water falls below the minimal level. The embossings [3] in the water tray are used as indicators for the maximal level.

Heating system

An air jacket heating is used for heating the work space. The arrangement of the heating elements ensures that condensate formation above the water reservoir is prevented as far as possible.

The outer door of the device is also heated. The heat radiated onto the interior glass door prevents condensate formation. The work space of the device always remains visible, despite high humidity.

Rear panel openings

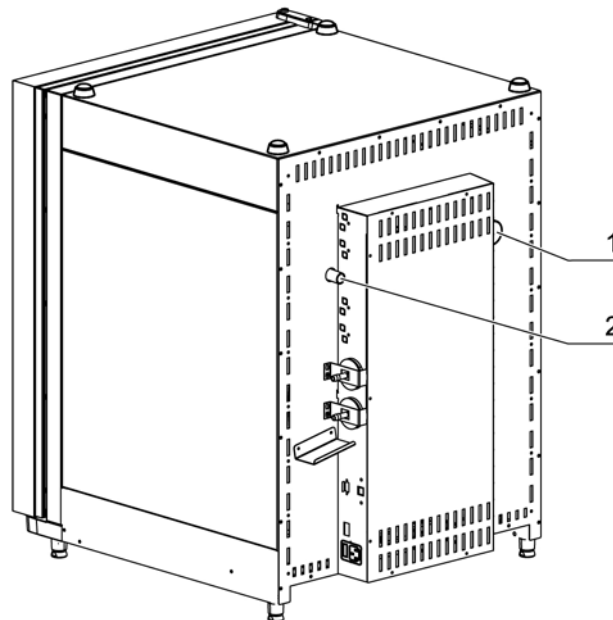

Figure 12. Rear panel openings

A pressure compensation opening with insert in the rear panel of the device allows a compensation between the pressures in the work space and in the operating room.

A sealable access port allows cables, hoses or additional sensors to be routed into the work space of the device.

- access port, Ø 42 mm [1]
- pressure compensation opening [2]

NOTE

Operating conditions:

When accessories are to be operated in the work space of the CO₂ incubator, the ambient condition requirements must be observed (see table below). The energy introduced into the work space affects the beginning of the temperature control range. When additional heating sources are introduced into the work space, condensation (e.g. at the glass door) may occur.

Introduced energy	Control range of the temperature	
	General	Example: RT* = 21° C
0 W	RT + 3° C	24° C
5 W	RT + 6,5° C	27,5° C
10 W	RT + 9,5° C	30,5° C
15 W	RT + 13° C	34° C
20 W	RT + 16° C	37° C
*RT = Ambient temperature		

Shelf system

The support rails [1] of the shelf system are perforated every 42 mm so that the support hooks [3] can be inserted variably for any culture container size required. The shelves [2] have an integrated tilt protection and withdrawal stop. For details of the shelf system, see Section „Start-up“.

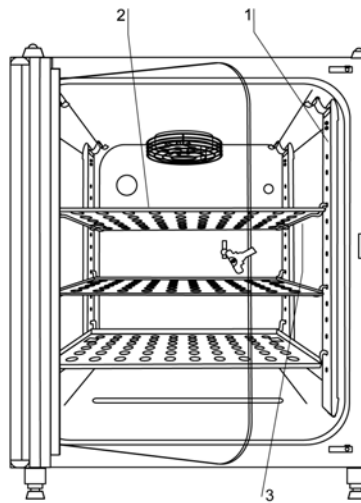

Figure 13. Shelf system

Water pump

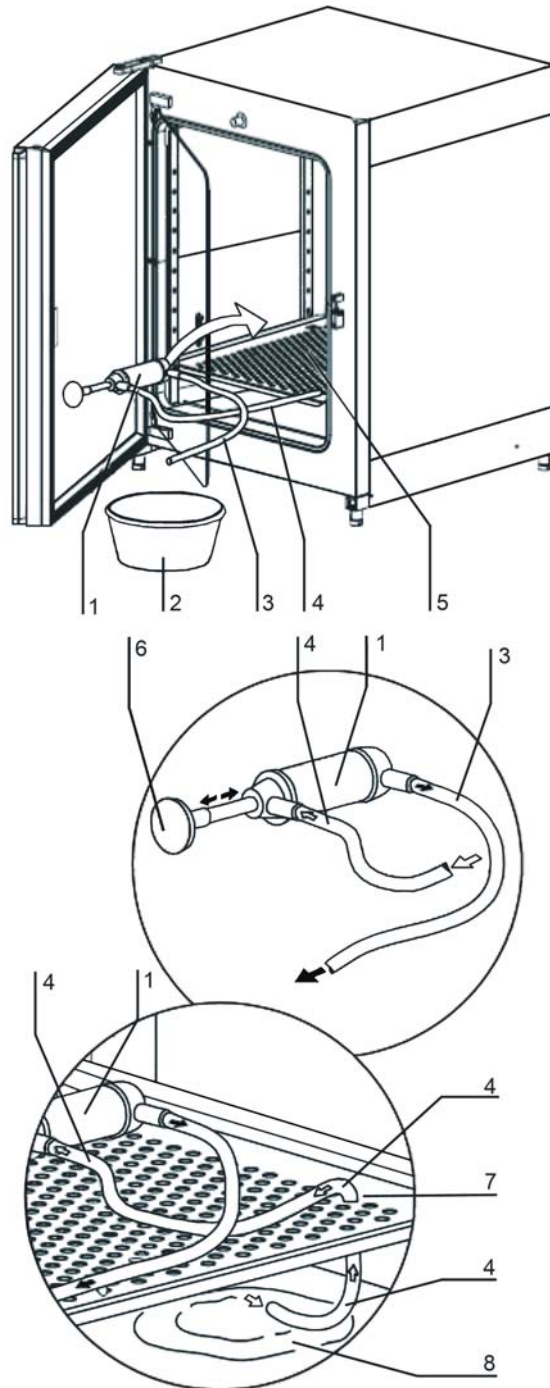

Figure 14. Water pump

The water pump serves for suction cleaning of the remaining water in the water reservoir. The water drain works through gravity.

1. Place the water pump [1] on lowest shelf [5].
2. Feed the inlet hose [4] through a hole [7] of the lowest shelf to the water reservoir [8].
3. Prepare a bucket [2].
4. Suck the water, therefore pump the water pump using the hand grip [6] about four times until water flows in the outlet hose.
5. Let the water run into the bucket [2] through gravity.
6. Wipe out the rests of the water at the floor plate of the water reservoir.

Start-up

Let the device adapt to the ambient conditions

NOTICE

Let the device adapt to the ambient conditions!

The device must adapt to ambient conditions prior to start-up.

- Set up the device in the operating room and let it adapt to the expected operating room temperature.
- After transport or storing under humid conditions a drying-out process must be performed. During the drying-out process the equipment cannot be assumed to meet all safety requirements of the IEC 61010-2-010 standard. The drying-out period is at least 2 hours.
- For a period of approx. 2 hours prior to switching it on.
- Open the device doors.

Preparing the work space

Upon delivery, the CO₂ incubator is not in a sterile state. Before the initial start-up, the device must be decontaminated.

Before the decontamination is performed, the following work space components must be cleaned:

- Support rails,
- support hooks,
- shelves,
- work space surfaces,
- work space seals and gaskets,
- glass door.

NOTE

Decontamination:

For details about the cleaning and disinfection of the device (see “Cleaning and disinfection” on page 85).

Installing the shelf system

Tools are not required for the installation of the shelf system. The support rails are secured using spring pressure. After the support hooks have been inserted into the rail, the shelves are pushed onto the support hooks.

Installation/removal of the support rail

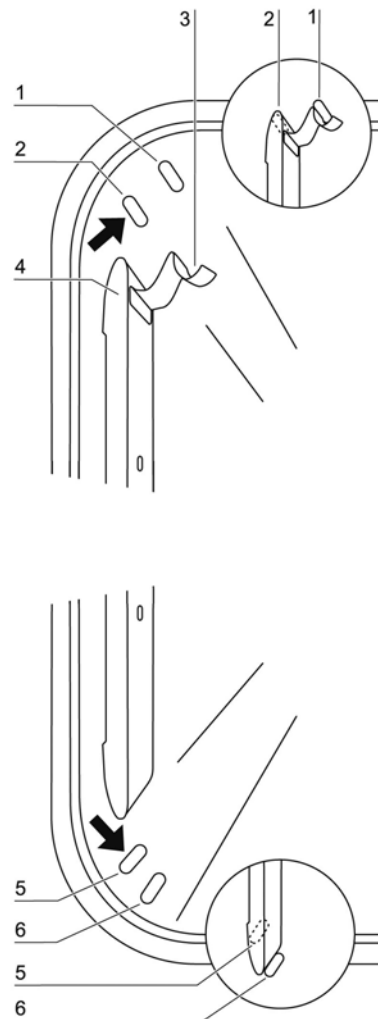

Figure 15. Support rail installation/removal

The support rails are held at the sides by the embossings [2] and [5] and secured by the embossings [1] and [6]. The support rails marked with the diamond shape are inserted at the rear panel of the device with the locksprings [3] facing upward.

1. Position the support rail [4] onto the lower embossing [6] and tilt it toward the work space side wall so that the rail is positioned over the two embossings [5] and [2].
2. Clamp the lockspring [3] behind the upper embossing [1].
3. To remove the support rails, pull the lockspring tab down out of the embossing and remove the rail.

Installing the shelf supports:

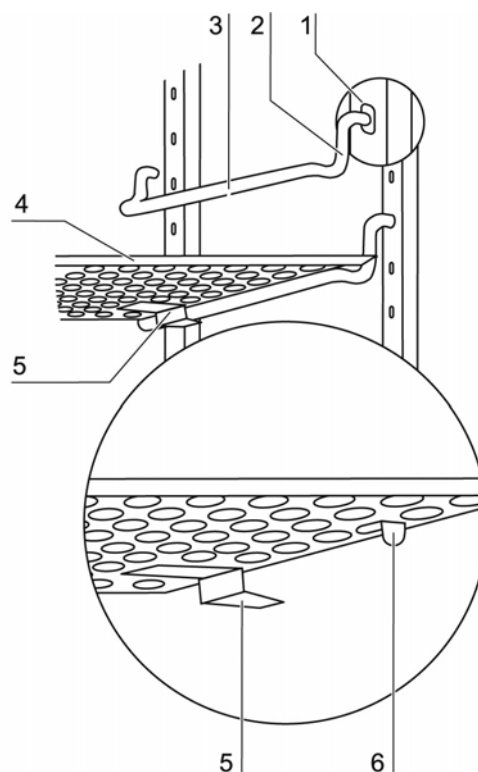

Figure 16. Shelf support installation

1. Insert the shelf supports [3] into the perforations [1] of the support rail with the bar facing down.
2. Make sure that the two vertical elements [2] of the shelf support are flush with the support rail.

Installing the shelves:

1. Push the shelf [4] onto the shelf supports with the tilt protection [5] facing the rear panel of the device. The tilt protection [5] is also used as a guide for the shelf.
2. Slightly raise the shelf so that the withdrawal stop [6] can be routed over the shelf supports.
3. Make sure that the shelf support is positioned in the two tilt protections in a way that allows it to move freely.

Levelling the device

1. Position a bubble level onto the center shelf or onto the roller holder.
2. Rotate the adjustable device stands using the supplied 24 mm wrench until the shelf is positioned horizontally in all directions. Perform the adjustment of the device stands from left to right and from rear to front.

Gas connection

NOTE

Gas quality:

The gas must have one of the following qualities:

- Purity 99.5 % min,
- medical gas quality.



CAUTION:

Overpressure!

The operating pressure of the gas applied to the device must not exceed 1 bar. If the gas is supplied at a higher pressure, the valves integral to the device may not close correctly and the gas supply control may be impaired.

Set the gas supply to a range between 0.8 bar min. and 1.0 bar max. and make sure that this pressure setting cannot be changed!

Installing gas pressure hoses

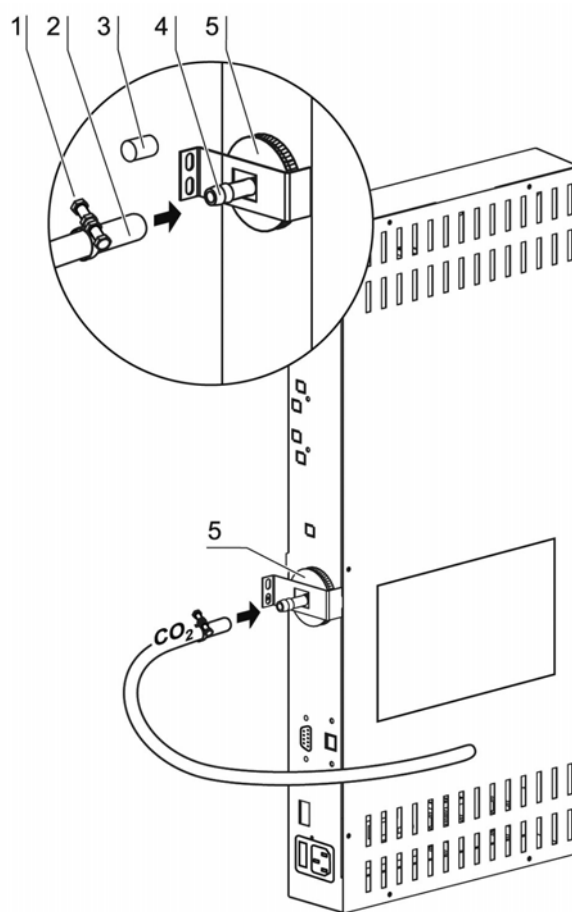

Figure 17. Installing gas pressure hoses

The gas supply from the gas supply system to the device is achieved using the supplied flexible gas pressure hoses:

1. Connect the gas pressure hose [2] to the sleeve of the gas supply system.
2. Remove the protective cap [3] from the sterile filter.
3. Slide the hose clamp [1] onto the gas pressure hose and connect hose to the sleeve [4] of the sterile filter [5].
4. Secure the gas pressure hose to the sleeve of the sterile filter using the hose clamp.

NOTE

Pressure compensation opening:

To ensure permanent pressure compensation, the pressure compensation opening must not be connected to an exhaust air system. The pipe of the pressure compensation opening must not be extended or redirected.

Gas connection

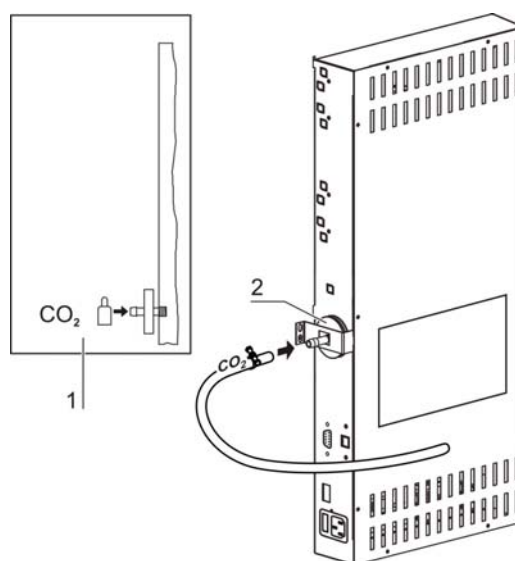

Figure 18. Gas connection

The gas supply from the gas supply system to the device is established using the supplied flexible gas pressure hoses (see “Installing gas pressure hoses” on page 36):

CO₂ connection:

- For a device with CO₂ connection, connect the gas supply to the sterile filter [2] in accordance with the connection diagram [1].

NOTE

Manual gas monitoring:

The filling level of the gas bottles must be checked every day.

Power supply connection



WARNING

Electric shock!

Contact with current-carrying components may cause a lethal electric shock.

Before connecting the device to the power supply, check plug and power supply cable for damage.

Do not use damaged components when connecting the device to the power supply!

The device must be connected only to a correctly installed and grounded power supply source:

- Fusing T 10 A
- Circuit breaker G 16

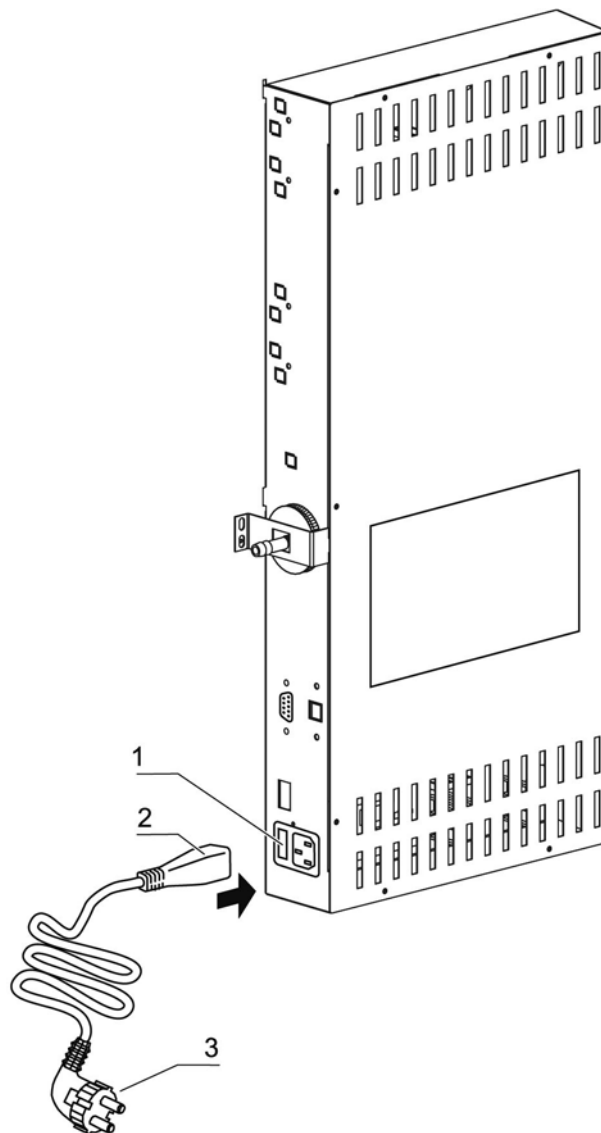

Figure 19. Power supply connection

Connection to the power supply system:

1. Before connecting the device to the power supply, check to see if the voltage of the power supply corresponds with the specifications on the nameplate on the front of the device. If the ratings given for voltage (V) and current (A) are not correct, the device must not be connected to the power supply.
2. Connect the IEC connector [2] to the socket [1] of the control box of the device.
3. Connect the grounding plug [3] of the power supply cable to a correctly grounded and fused socket.
4. Make sure the power supply cable is not subjected to tensile or compressive force.

Connecting the RS 232 interface

The RS 232 data communication interface has been designed for a cable connection with 9-pin connector and a contact assignment of 1:1.

Data exchange is accomplished by a predefined structure of command sequences (see annex at the end of this section).

NOTE

Data communication diagram:

The command sequence syntax as well as the RS 232 interface data communication diagram are described in the annex at the end of this section.

Connecting the devices:

1. Turn the PC off.
2. Connect the serial interface cable connector (not included in the standard equipment) to the socket at the device supply interface at the rear of the device.
3. Connect the second connector to an unassigned serial port COM 1 / COM 2 etc. at the PC.
4. Turn the PC on.

Connecting the alarm contact

NOTE

Skilled work:

Thermo Scientific warrants the operational safety and the operativeness of the device only if installation and repairs are performed properly.

The connection of the device to an external alarm system must only be carried out by adequately trained and authorized expert electrical/telecommunication personnel!

Function:

When system errors and failures occur in the temperature or gas control circuits, an alarm message is issued to the connected alarm/monitoring system. The potential-free contact (1 changeover contact) has been designed for the following circuits:

Alarm relay:

Circuit	Voltage	External fusing
Circuits with system voltage	max. 250 V ~	max. 6 A
SELV circuits (cf. VDE 0100, Part 410)	25 V ~	max. 2 A
	60 V =	max. 1 A
SELV-E circuits (cf. VDE 0100, Part 410)	50 V ~	max. 1 A
	120 V =	max. 0.5 A

Operating states	Contact 4 - 1	Contact 4 - 3
Operating state power failure "off"	X	O
Operating state power failure "on"	O	X
Failure: power failure "off"	O	X
Failure: power failure "on"	X	O
X: Contact closed / O: Contact open		

NOTE**Switching structure:**

The alarm relay switches for all failures reported by the control loops (see "Error messages" on page 78).

Connection example:

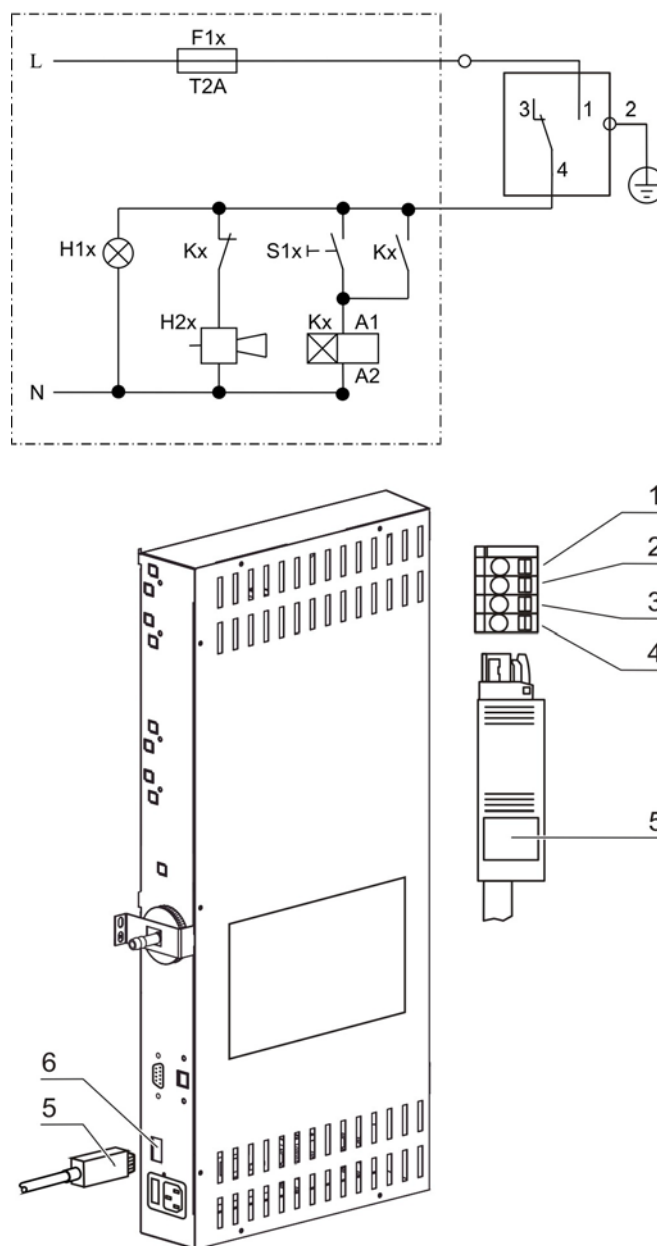

Figure 20. Connection example

The connector [5] for the connecting cable is included in the standard equipment. The values for the operating voltage of the external circuits and of the fusing of the alarm system are given in the table on the previous page.

1. Connect the individual conductors [1] to [4] of the connecting cable as shown in the wiring diagram.
2. Connect the connector [5] of the alarm system connecting cable to the interface [6] at the control box at the rear panel of the device.

Operation

Preparing the device

The device must only be released for operation after all major measures for the start-up have been taken.

Device check:

Prior to starting operation, the following device components must be checked for their correct function

- Gas hoses must be seated tight on the connecting filter and must be secured using a hose clamp.
- The access port must be capped.
- The pressure compensation opening must be permeable, its insert must be installed in the work space.
- The glass door seal must not be damaged.
- The glass door measurement opening must be capped.
- The shelf system components must be installed safely.

Decontaminating the device work space:

Run the 90°C decontamination routine (see “Running the 90°C routine” on page 65) or decontaminate the work space according to the hygiene regulations set forth by the operator.

NOTE

Hygiene regulations:

Prior to any operation, the user must clean and disinfect the work space in accordance with the hygiene regulations set forth by the operator to protect the cultures.

The “Principles of good microbiological proceedings” at the annex of these instructions can be used as safety information for personnel working with the device.

NOTE

Water supply:

A sufficient quantity of treated water of the following quality must always be available for the running operation:

- distilled, fully demineralized, and
- autoclaved, sterile.

When the filling level drops below a minimum value, it must be possible to top up water during the work process.

Capacity 3.0 l.

Starting operation

1. Fill the water tray with a sufficient quantity of processed water. Do not exceed the upper level mark.
2. Make sure that the CO₂ supply system valves are open.
3. Turn the device on using the power switch.
4. Set the set values for temperature and CO₂ content on the operating panel.
5. Start 90°C routine.

Starting the device:

6. Start the device with the auto-start routine (see “Activating auto start” on page 57).
7. The progress indicator auto-start appears on the display, and the automatic start routine is run.
8. The temperature control adjusts the temperature to the selected set value, humidity rises.
9. When temperature and relative humidity are constant, the automatic adjustment of the CO₂ measuring system is performed.
10. The CO₂ control supplies the set amount of CO₂.
11. If the auto-start routine has been completed, the progress indicator is hidden, and the main menu is displayed. The device is operational.
12. Load the work space with cultures

NOTE

Duration of the auto-start routine:

When the device is cold and when the ambient temperature is low, the auto-start routine may take up to 10 hours.

Loading:

To ensure sufficient air circulation and even heating of the samples, the loading surface within the work space should be used up to 70% max. Voluminous objects in the work space that dissipate heat may impair heat distribution.

Handling and control (touchscreen controller)

Power switch

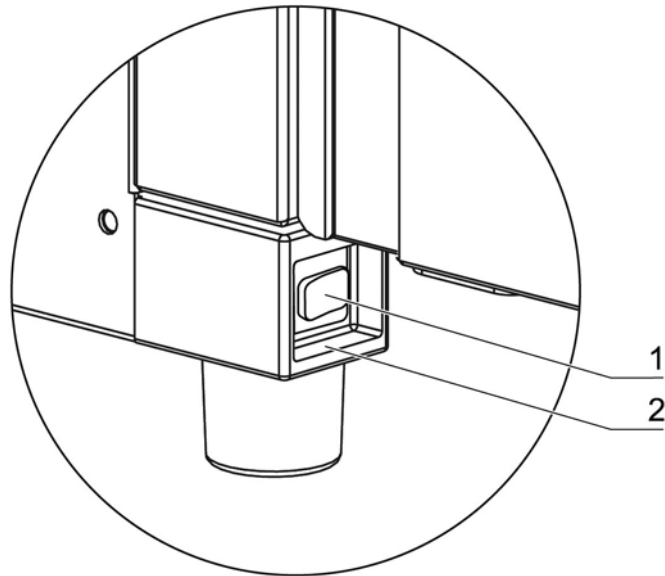

Figure 21. Power switch

Depending on which side the door hinges are installed, the power switch [1] is integral to the front cover [2] of one of the front device stands.

- To turn the device on: Press the power switch [1]; the switch illumination comes on.
 - After a short audible signal and a short dark phase, the touchscreen display appears.
 - The control loop sensors pass the heat-up phase (see “Heat-up phase of the control loop sensors” on page 49).
- To turn the device off: Press the power switch; the switch illumination goes off.

Operating panel and operating structure

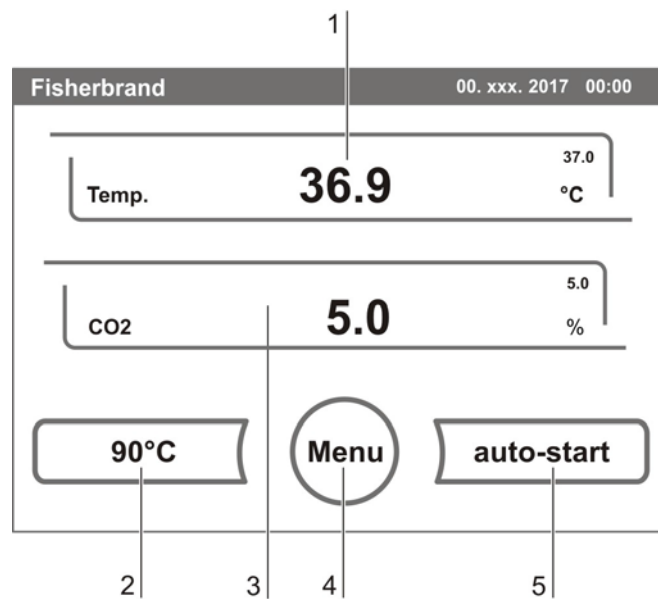

Figure 22. Pressure-sensitive areas

The control panel works as a touchscreen and can be controlled performing light pressure on the pressure-sensitive areas of the screen using a finger or a blunt pin:

- Temperature display [1]
- CO₂ display [3]
- 90°C key [2]
- menu key [4]
- auto-start key [5]

NOTE

Extended pressure-sensitive area:

To accept a failure message, the entire touchscreen can be used as a pressure-sensitive area.

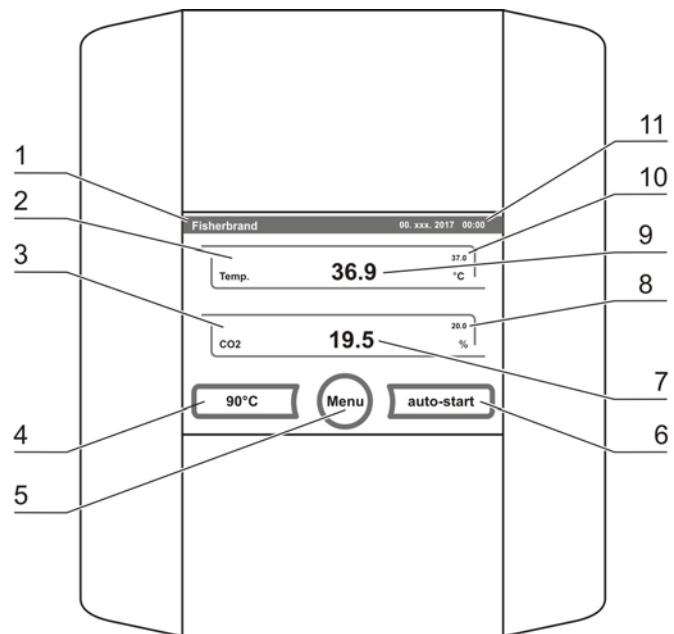
Touchscreen:**Figure 23.** Touchscreen

Function keys and value displays of the operating panel:

1. Type designation of the device
2. Temperature display
3. CO₂ display
4. Key for starting the 90°C decontamination routine
5. Key for opening the menu navigation
6. Key for starting the auto-start routine
7. Actual value CO₂
8. Set value CO₂
9. Temperature actual value
10. Temperature set value
11. Current date and time

Structure of the operating levels:

Operation is divided into three levels:

- **A:** Direct access to the control loop settings: Temperature, CO₂ set value and bottle turning device (optional),
- **B:** Start of the device routines 90°C or auto-start,
- **C:** Navigation through the submenus for device configuration.

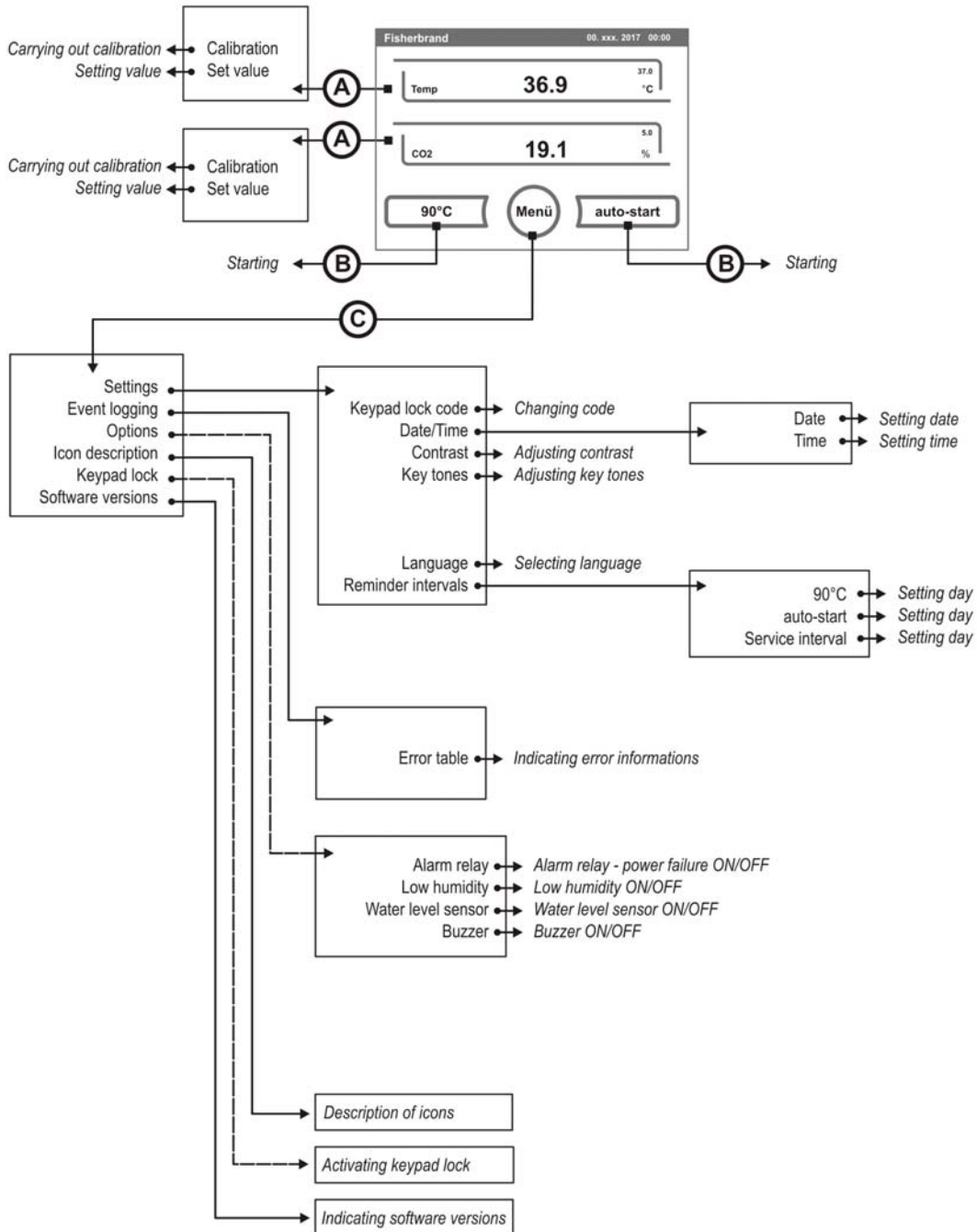

Figure 24. Menu structure overview

Factory presettings of the Touchscreen controls

Upon delivery of the device, the following set values have been preset:

- Temperature: 37°C
- CO₂ content: 0.0%

NOTE

CO₂ control:

Since the CO₂ concentration of the air is nearly 0%, the CO₂ control and the control loop error monitoring system are disabled at a set value of 0%.

Heat-up phase of the control loop sensors

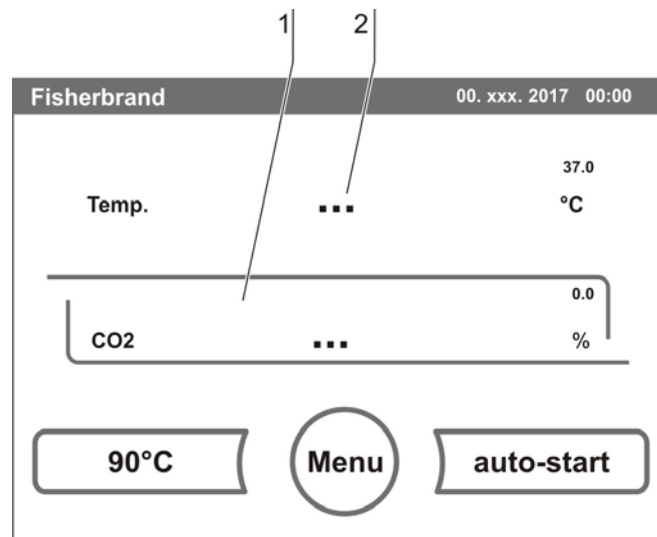

Figure 25. Heat-up phase display

When the device has been switched on, the control loop sensors pass through a heat-up phase of varying duration during the start process:

Temperature control loop	10 s
CO ₂ control loop	10 s
CO ₂ control loop with IR measuring cell	3 min

The start process is indicated by an audible signal. During the heat-up phase, the displays show dots (...) instead of values:

- CO₂ display [1]
- Temperature display [2]

After the heat-up phase has been completed, the control loop actual values are indicated.

Event actions for settings

Key response:

Pressing a key can increase or reduce a value gradually:

- When the – key [4] or the + key [6] is kept depressed, the system switches to quick run,
- after the key has been kept depressed for more than 3 seconds, the quick run speed increases.

NOTE

Saving the settings:

To save changed values, press the Enter key.

Resetting the settings:

Unless a user action (contact with the pressure-sensitive areas and keys) occurs within 30 seconds, the system automatically exits the menu and the most recently confirmed setting defaults.

Setting the temperature set value

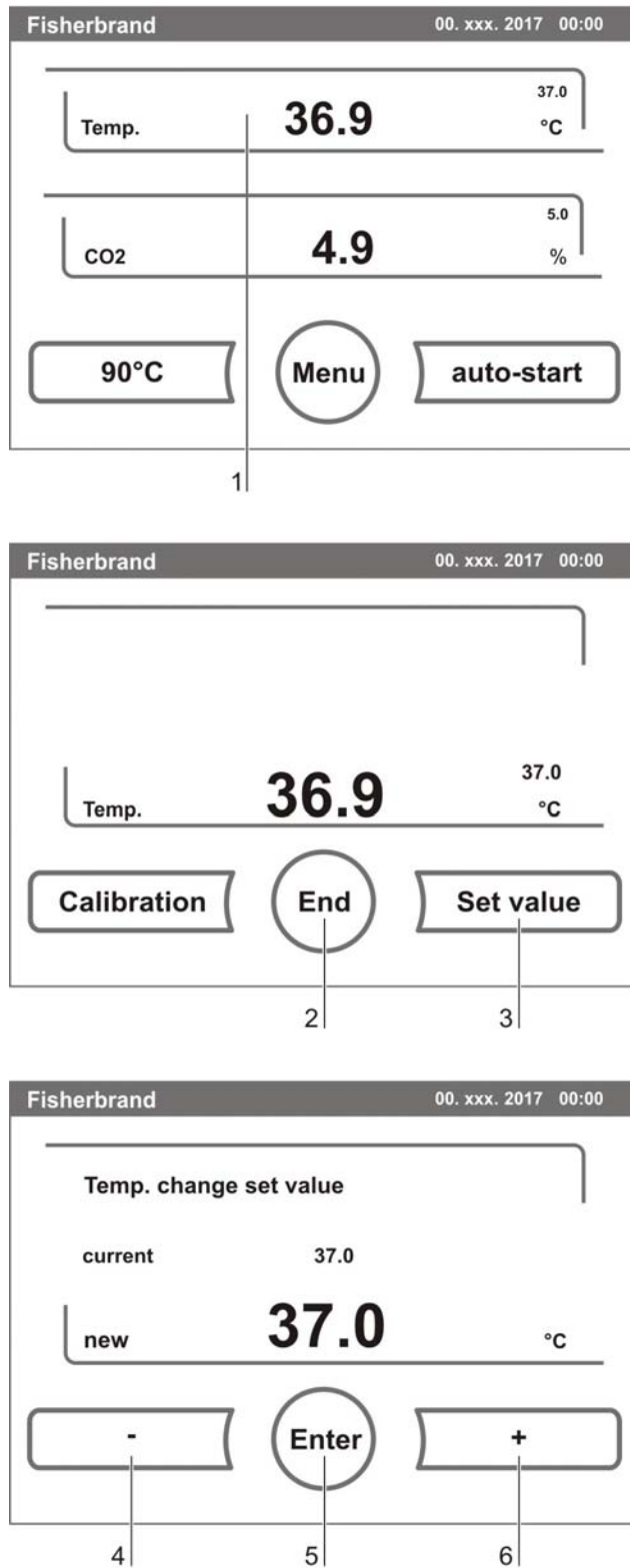

Figure 26. Setting the temperature set value

1. Press the **TEMPERATURE DISPLAY** key [1].

- The Temperature menu is displayed.

2. To exit the Temperature menu:

- Press the **END** key [2].

3. To set the temperature set value:

- Press the **SET VALUE** key [3].

To increase the set value:

- Press the **+** key [6].

To reduce the set value:

- Press the **-** key [4].

4. To accept and save the set value:

- Press the **ENTER** key [5].

- The system returns to the main menu. The temperature displays shows the actual value currently measured in the work space.

Setting the CO₂ set value

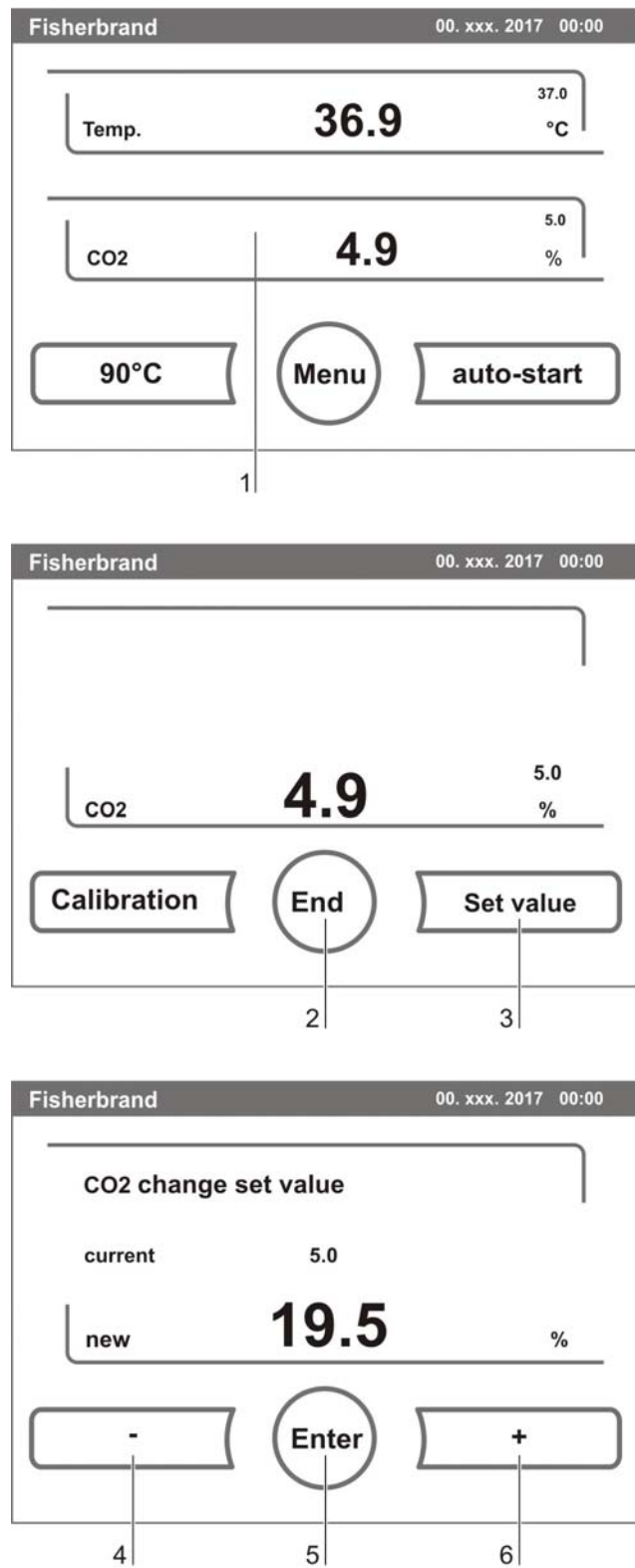

Figure 27. Setting the CO₂ set value

1. Press the CO₂ **DISPLAY** key [1].
 - The CO₂ menu is displayed.
2. To exit the CO₂ menu:
 - Press the **END** key [2].
3. To set the CO₂ set value:
 - Press the **SET VALUE** key [3].

To increase the set value:

 - Press the **+** key [6].

To reduce the set value:

 - Press the **-** key [4].
4. To accept and save the set value:
 - Press the **ENTER** key [5].
 - The system returns to the main menu. The CO₂ display shows the actual value currently measured in the work space.

NOTE

Deactivating the CO₂ control loop:

To deactivate the CO₂ control, the set value is set to 0%.

If the control loop is deactivated, error monitoring is enabled as well.

Gas monitoring:

The switching state of the CO₂ control loop does not affect the function of the optional gas monitoring system. The gas monitoring system remains active even when the CO₂ control is switched off.

The control loop error monitoring system (optional) is enabled.

Auto-start routine

The auto-start function is an automated routine for the start and the subsequent adjustment of the CO₂ measuring system. After the start, the device control adjusts the temperature to the set value while humidity is generated. When temperature and relative humidity have reached constant values, the CO₂ measuring system is automatically adjusted to these values, and the work space is supplied with the preset quantity of CO₂.

NOTE

Application of the auto-start routine:

To ensure that the specified accuracy of the CO₂ measuring system is maintained, the device should always be started using the auto-start routine if

- a difference of more than 1 °C is entered upon setting the temperature set value,
- the Low Humidity function is enabled/disabled,
- the device is restarted after an extended interruption of operation.

The auto-start routine should be run at least every three months on the occasion of cleaning and maintenance works.

Duration of the routine:

Running the routine usually takes 5 to 7 hours. At low room temperatures and when the device is cold, it may take up to 10 hours until the auto-start routine has been completed. If the glass door is opened or if the power supply of the device is interrupted while the routine is running, the routine is interrupted and rerun after the glass door has been closed or the power supply has been reestablished.

Start conditions for the auto-start routine:

Prior to running the auto-start routine, set the CO₂ set values to the desired values and make sure that the atmosphere in the work space only consists of ambient air.

The floorpan of the device must be filled with a sufficient quantity of water.

Conditions that prevent the start of the auto-start routine:

The auto-start routine cannot be started if one of the following failure conditions exists.

Temperature control loop:

- Sensor breakage,
- actual value above set value (excessive deviation),
- actual value below set value (excessive deviation),
- set value not plausible,
- calibration values too high or too low,
- sensor communication failure,
- sensor parameter not plausible,
- no communication with LM 75.

NOTE

Control loop for CO₂ gas supply:

- No communication with sensor.

In this case, the auto-start key is dimmed and its function is not available.

Faulty cancellation of the auto-start routine:

The auto-start is canceled if:

- an error is detected in the temperature control loop,
- an error is detected in the CO₂ control loop,
- the water filling level is insufficient.

auto-start-Dry execution of auto-start routine:

If the auto-start routine is to be run dry (without water in the floorpan of the work space), the water level sensor must be disabled prior to its start (see "Options" on page 69).

Activating auto start

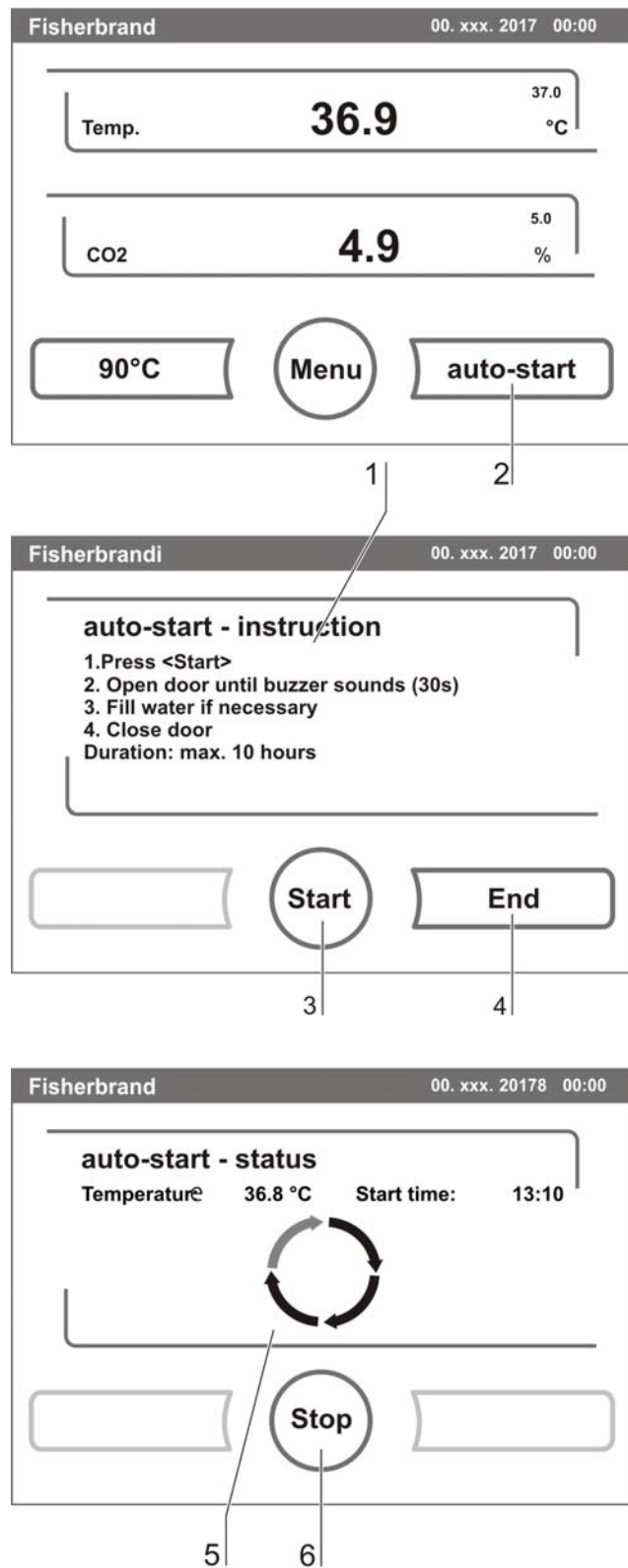

Figure 28. Activating the auto-start routine

Preparations for the start:

1. Make sure that the CO₂ gas supply system valves are open.
2. Fill the floorpan of the work space with a sufficient quantity of water. The filling level must not exceed the upper filling level mark.
3. Set the set values for temperature, CO₂ on the touchscreen.

auto-start routine activation:

1. Press the auto-start key [2].
 - The auto-start-instruction menu [1] is displayed.
2. To exit the auto-start-instruction menu and cancel auto-start:
 - Press the **END** key [4].
3. Activate the auto-start routine:
 - Press the **START** key [3].
4. To air the work space, open both device doors.
5. When the audible alarm sounds after 30 seconds, close both device doors.
 - The trend status indicator [5] is displayed.
6. During the progress, the status indicator displays the following information:
 - Temperature,
 - start time.

NOTE

Cancellation:

The auto-start routine can be canceled at any time!

Press the Stop key [6].

Automatic restart:

The auto-start routine is restarted automatically if the routine is canceled due to one of the following events:

- The glass door is opened,
- the power supply is interrupted.

Interrupting the auto-start routine

If the **STOP** key in the status display is depressed (see above), the auto-start routine is interrupted and the auto-start stop dialog box is displayed for a safety scan. The routine can now be permanently canceled or resumed.

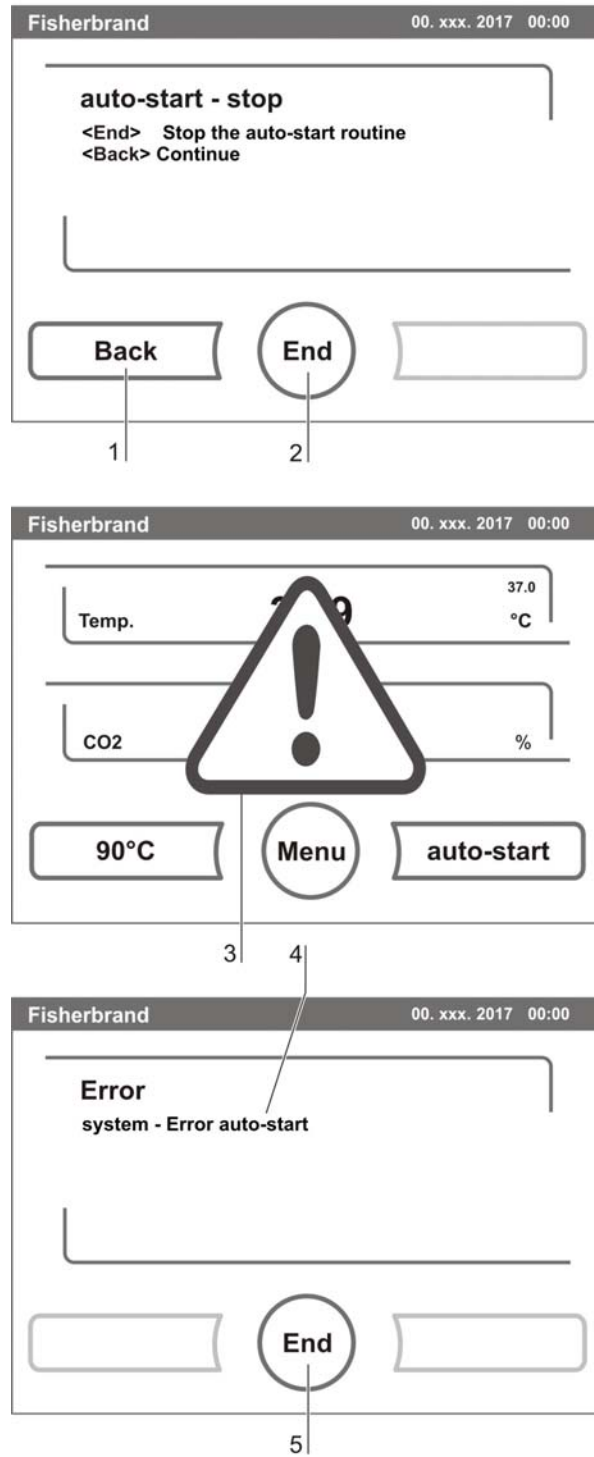

Figure 29. Interrupting the auto-start routine

1. To resume the auto-start routine:
 - Press the **BACK** key [1].
 - The system returns to the status display, and the auto-start routine is resumed.
2. To cancel the auto-start routine:
 - Press the **END** key [2].
 - The warning triangle [3] is displayed as a failure message together with the audible signal.
3. To accept the failure message:
 - Press any position on the display.
 - The **ERROR** dialog box with the description of the error is displayed.
4. To end the auto-start routine:
 - Press the **END** key [4].
 - The system returns to the main menu.

Running the 90°C routine

The 90°C routine is an automatic decontamination routine for disinfecting the device work space. For a detailed description of this device function (see “90°C decontamination routine” on page 89).

User configuration

The user configuration settings allow the user interface and the additional device functions to be adjusted to the requirements of everyday operation. The user configuration menu is split into six categories:

- Settings
- Event logging
- Options
- Icon description
- Keypad lock
- Software versions

To make a user-specific setting in a dialog box, navigate through the submenus listed in the illustrations and open the dialog box.

Settings

The input dialogs of the **SETTINGS** category comprise all settings for the individual configuration of the user display screen and the user interface:

- Keypad lock coding
- Date/time setting
- Contrast setting
- Key tone setting
- Interface configuration
- User display screen language setting
- Reminder interval setting

Changing the keypad lock code:

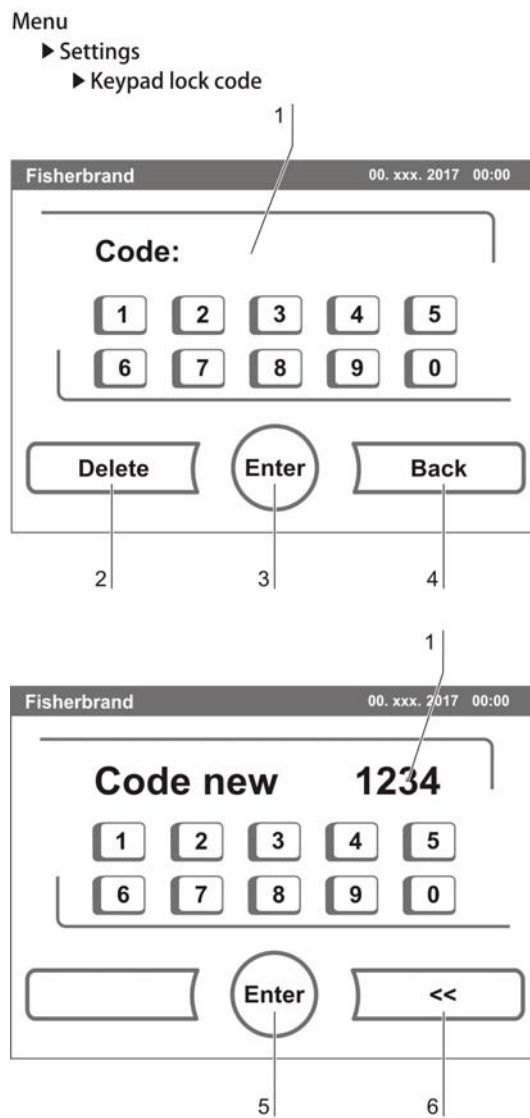

Figure 30. Changing the code

The keypad lock prevents the unauthorized changing of the operational settings. Only those keys are locked where values can be entered.

The keypad is locked by entering four numbers.

- Upon delivery, the default code is: 0000.

This default can be changed into a user-defined code that is then enabled using the **KEYPAD LOCK** dialog box (see “Enabling/disabling the keypad lock” on page 76).

1. To enter the default 0000:
 - Press the corresponding numeric keys.
 - The number combination is displayed hidden in the input box [1].
2. To delete the input numbers:
 - Press the **DELETE** key [2].
3. To exit the menu:
 - Press the **BACK** key [4].
4. To confirm the input:
 - Press the **ENTER** key [3].
 - The system changes to the **CODE NEW** menu.

Entering the new 4-digit code:

- Press the corresponding numeric keys.
- The number combination is displayed in the input box [1].

Fig.30: To set the cursor to the left to overwrite a value:

5. Press the **BACKSPACE** key (<<) [6].
6. To accept and save the input value:
 - Press the **ENTER** key [5].
 - The system returns to the Settings menu.

NOTE

Changing the user-defined code:

The user-defined code can be changed as often as required using the same procedure:

- **Activate the recoding function by entering the valid code,**
- **enter the new code and confirm it.**

Setting date / time:

The input dialog allows date and time to be set to the required time zone.

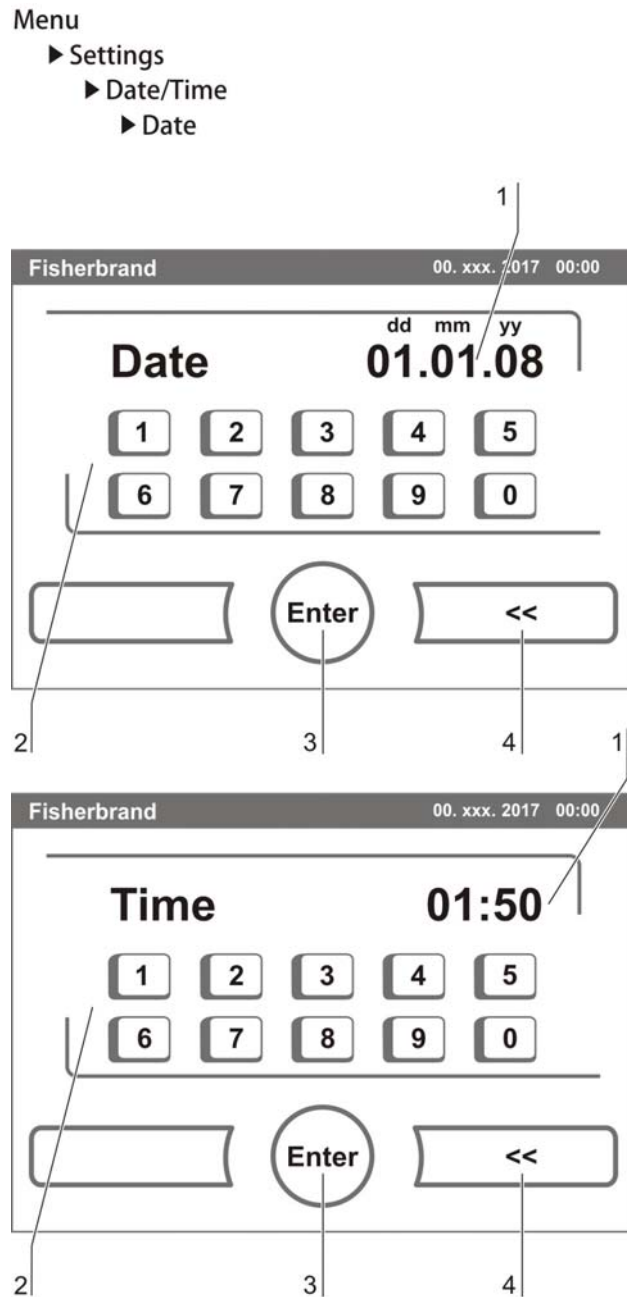

Figure 31. Date / time setting

1. To enter the date:
 - Press the numeric key [2].
 - The input numbers are displayed in the input box [1].
2. To set the cursor to the left to overwrite a value:
 - Press the **BACKSPACE** key (<<) [4].

3. To accept and save the input value:
 - Press the **ENTER** key [3].
4. The system returns to the Date/Time menu.
5. Enter the time accordingly.
6. To accept and save the input value:
 - Press the **ENTER** key [3].
 - The system returns to the Date/Time menu.

Setting the contrast:

The input dialog allows the color contrast of the operating panel to be set within the value range of 48% to 80%.

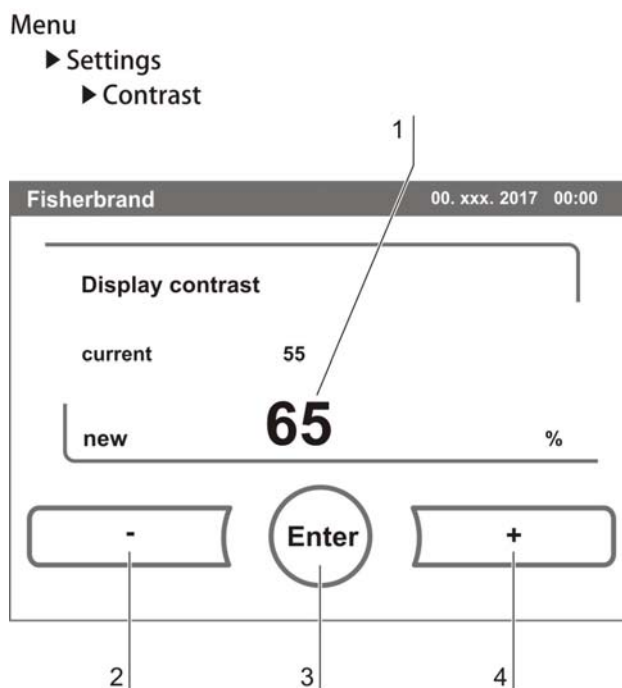

Figure 32. Display contrast setting

1. To increase the value:
 - Press the + key [4].
2. To reduce the value:
 - Press the - key [2].
3. The value change appears in the display [1].
 - To accept and save the change:
 - Press the **ENTER** key [3].
 - The system returns to the Settings/Setup menu.

Setting the key tone:

The input dialog allows the loudness of the key tone that sounds whenever a key is depressed to be set.

The value range is 0 to 100. The change occurs in increments of 5%.

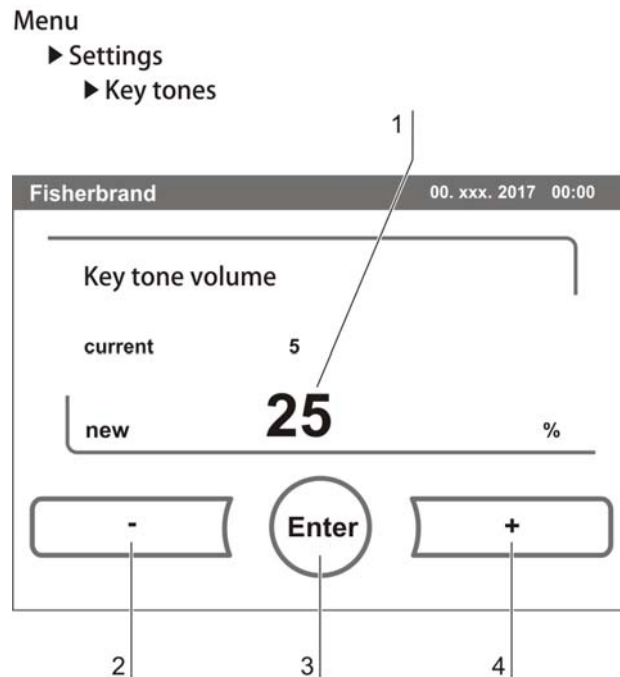

Figure 33. Key tone setting

1. To increase the value:
 - Press the + key [4].
2. To reduce the value:
 - Press the - key [2].
3. The value change appears in the display [1].
4. To accept and save the change:
 - Press the **ENTER** key [3].
 - The system returns to the Settings/Setup menu.

Setting the user display screen language:

The input dialog allows the language of the display screen to be set. Five languages are available:

- German
- English
- Spanish
- French
- Italian

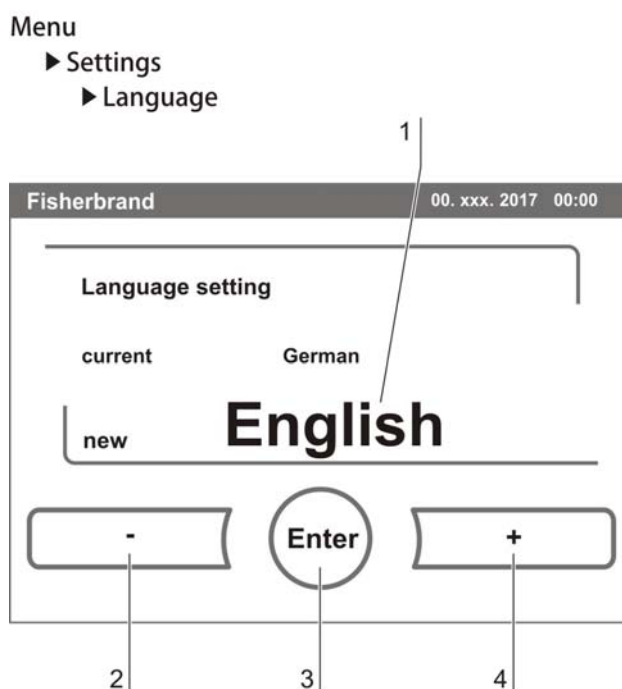

Figure 34. Language setting

1. To browse upward in the selection:
 - Press the + key [4].
2. To browse downward in the selection:
 - Press the - key [2].
3. The new language appears in the display [1].
4. To accept and save the selection:
 - Press the **ENTER** key [3].
 - The system returns to the Settings menu.

Setting the reminder intervals:

The reminder intervals are integral components of the alarm and monitoring system of the device control. For the two essential functions 90°C and auto-start as well as for routine service work, the user can set dates that trigger an alarm whenever they occur.

The counting begins at 00:00 hrs of the day on which the previously set reminder interval has elapsed.

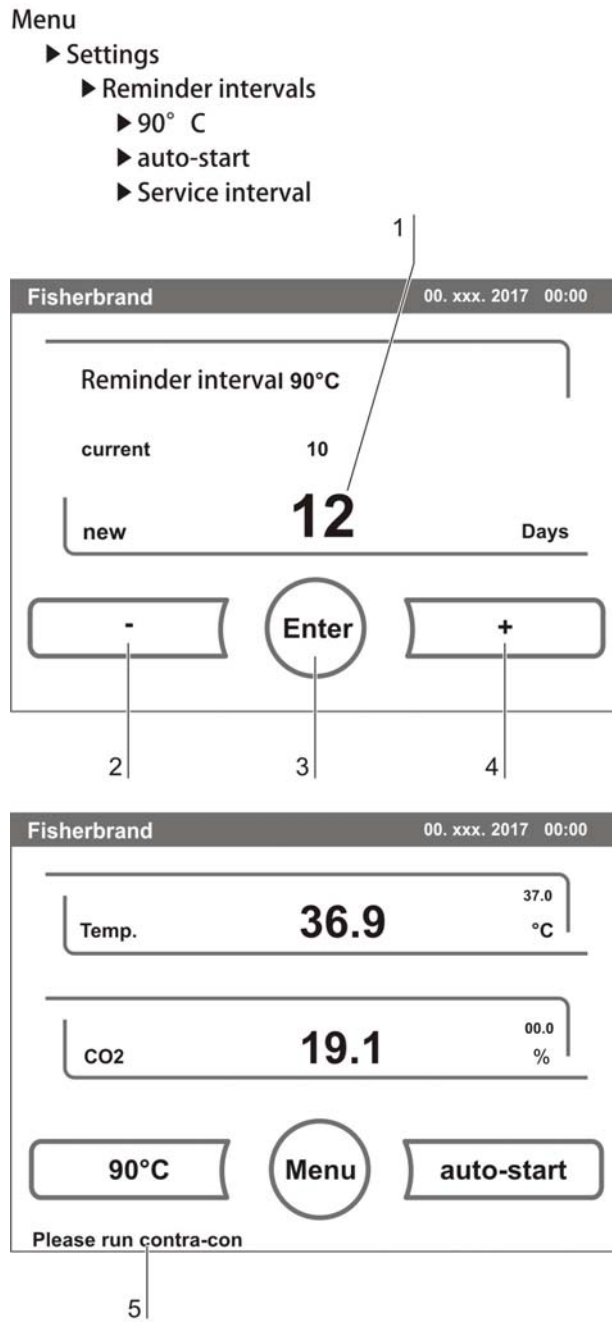

Figure 35. Reminder interval setting

1. To increase the number of days:
 - Press the **+** key [4].
2. To reduce the number of days:
 - Press the **-** key [2].
3. The value change appears in the display [1].
4. To deactivate the reminder interval:
 - Set the value to **OFF**.
 - Press the **-** key [2].
5. To accept and save the change:
 - Press the **ENTER** key [3].
 - The system returns to the Reminder Interval menu.

On the due date, the display shows a reminder message [5] for the activated reminder interval.

- **90°C:** Run 90°C routine.
- **auto-start:** Run auto-start. Is displayed after the 90°C decontamination routine has been run successfully.
- **Service interval:** Request service. The service message can be confirmed. In this case, the Request Service icon is displayed.

After the routines have been run successfully, the reminder messages are hidden.

Factory settings:

90°C decontamination routine	90 days
auto-start routine	Off
Service interval3	65 days

Displaying the error table:

The error table lists the errors detected by the device-integral monitoring system in descending chronological order. The most recently detected error is listed at the top position of 22 possible entries. An entry consists of the control loop in which the error occurred, the date, the time, and an error description. The error table can be displayed but not edited.

If the event display consists of two pages, the user can browse through the list. The status indicator [2] indicates which page of the two is currently being displayed.

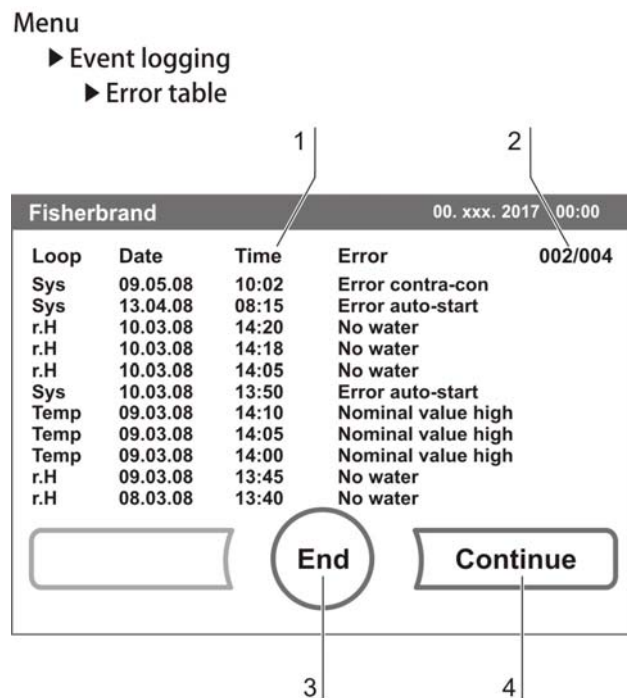

Figure 36. Error table display

1. To browse forward in the error table:
 - Press the **CONTINUE** key [4].
2. To browse backward in the list:
 - Press the **PREVIOUS** key.
3. To exit the display:
 - Press the **END** key [3].
 - The system returns to the Event Logger menu.

NOTE

Troubleshooting:

For a detailed overview of causes for errors and their correction, please refer to the end of this chapter!

Options

The input dialogs of the **OPTIONS** category comprise all settings of the functional device options:

- Alarm relay
- Low humidity
- Water level sensor

- Audible alarm
- CO₂ (optional)

Setting the alarm relay:

The alarm relay is the interface for the connection of the device-integral monitoring system to an external monitoring system. Depending on the required input signal of the external monitoring system, network monitoring can be enabled or disabled. If network monitoring is enabled, a power failure is detected as an error. The relay cannot be switched off (see “Connecting the alarm contact” on page 39).

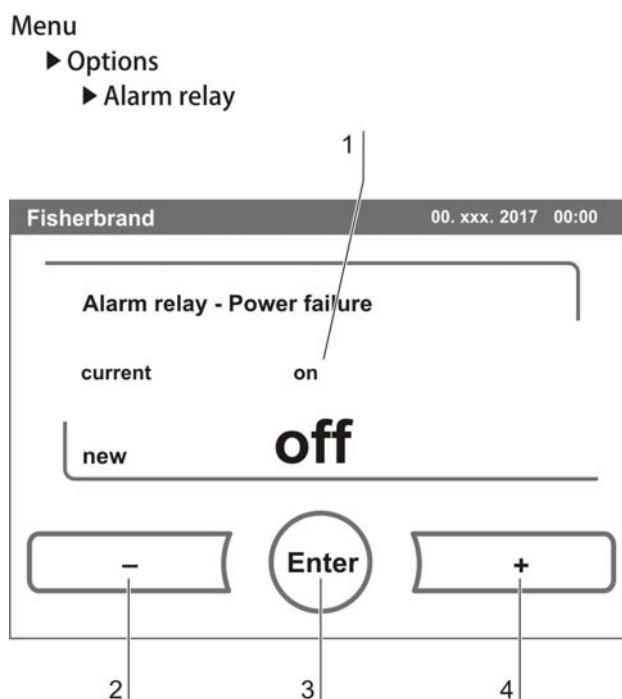

Figure 37. Alarm relay setting

1. To toggle between two states [1]:
 - Press the + key [4].
 or
 - Press the - key [2].
2. To accept and save the change:
 - Press the **ENTER** key [3].
 - The system returns to the Options menu.

Setting low humidity:

If condensation occurs on the culture containers due to high relative humidity, the humidity in the work space can be set to a lower level. At the factory, the device control is preset to high humidity (approx. 93% relative humidity).

By enabling the Low Humidity feature, the relative humidity in the work space is lowered from approx. 93% to approx. 90%. The modification requires an extended adaption phase. To effectively prevent condensation on culture containers, it must be used as a permanent setting.

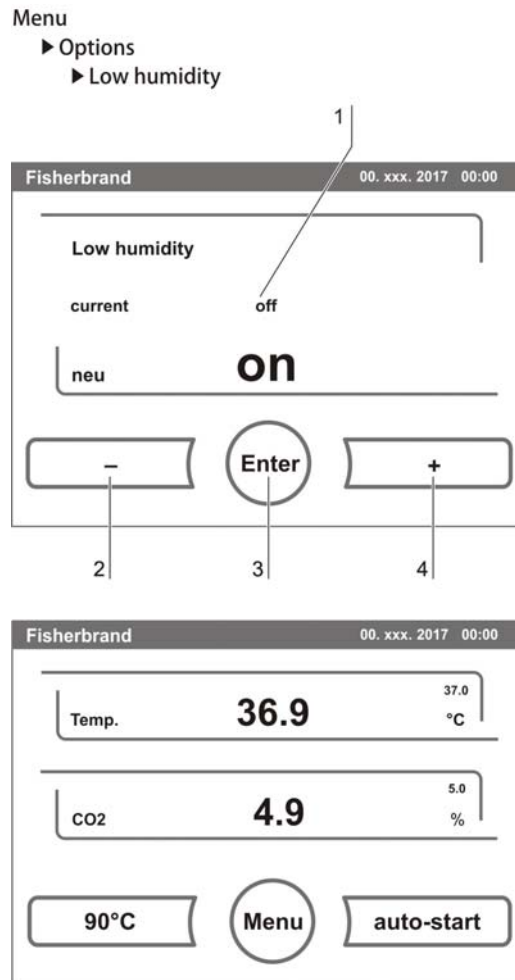

Figure 38. Low humidity setting

1. To toggle between two states [1]:
 - Press the + key [4].
 or
 - Press the - key [2].
2. To accept and save the change:
 - Press the **ENTER** key [3].
 - The system returns to the Options menu.

NOTE

Low humidity:

The enabling/disabling of the Low humidity function is entered into the event list.

If the Low humidity function is enabled, the corresponding icon [5] is displayed in the main menu.

Switching the water level sensor on/off:

For incubation operation with ambient humidity or if the auto-start routine is to be run dry (without water), the water level sensor can be switched off.

This prevents alarm messages for the water level sensor by the device-integral monitoring system from being issued.

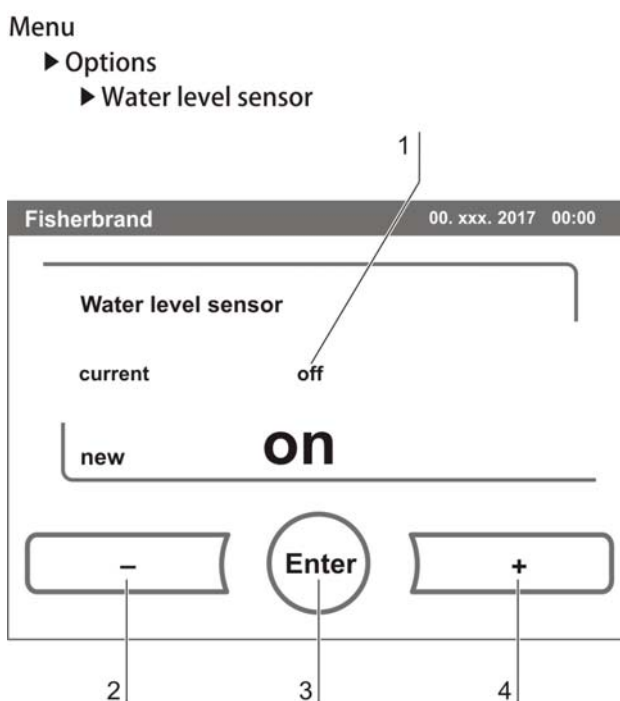

Figure 39. Water level setting

1. To toggle between two states [1]:
 - Press the + key [4].
 or
 - Press the - key [2].
2. To accept and save the change:
 - Press the **ENTER** key [3].
 - The system returns to the Options menu.

Switching the audible alarm on/off:

If the device-integral monitoring system detects an error:

- an audible alarm sounds
- in addition to the visual error message and the switching of the alarm relay.

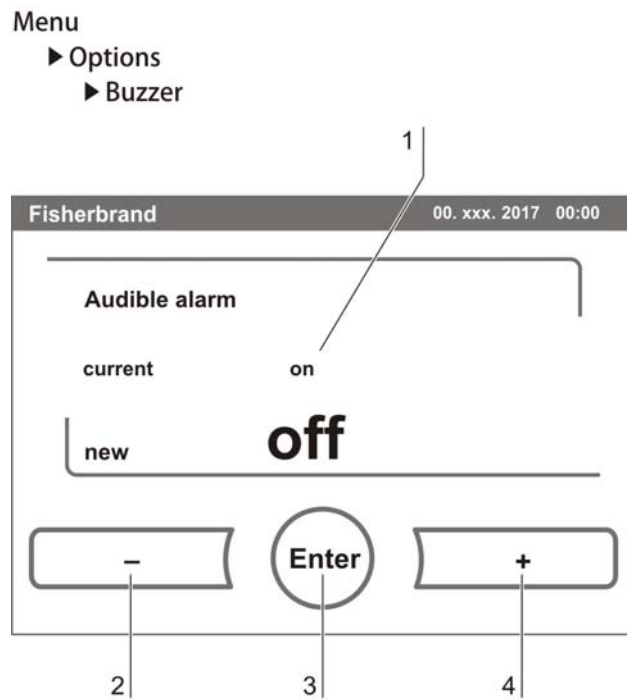

Figure 40. Alarm relay setting

The audible alarm can be permanently disabled:

1. To toggle between two states [1]:
 - Press the + key [4].
 or
 - Press the - key [2].
2. To accept and save the change:
 - Press the **ENTER** key [3].
 - The system returns to the Options menu.

Icon description

Essential operating states or error messages, e.g. keypad lock [3], low humidity [4] or bottle turning device [5] are displayed as icons in the touchscreen main menu in addition to the entries in the event or in the error table.

The Icon Description dialog box [1] explains the meaning of the individual icons.

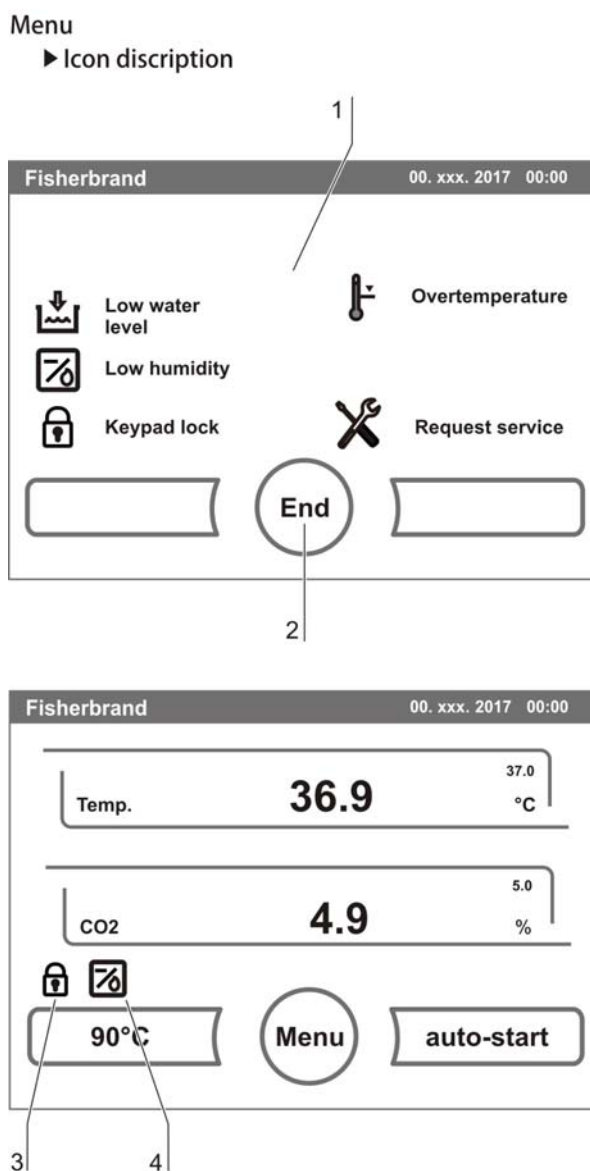

Figure 41. Icon description overview

- To exit the display:
 - Press the **END** key [2].
 - The system returns to the Configuration menu.

Function of the individual icons:**Low water level:**

This error indicator shows that the water level sensor has detected a low water level.

Low humidity:

This function indicator shows that the relative humidity in the work space has been lowered from approx. 93% to approx. 90%.

Keypad lock:

This function indicator shows that the keypad lock has been activated so that currently the settings cannot be changed.

Overtemperature:

This error indicator shows that the device control has activated the overtemperature protection and has switched to backup control.

Gas cylinder empty:

Error message, indicating, that the filling level of one or of several gas cylinders is too low to ensure regular gas supply.

The monitoring function is available only for device versions with the optional gas monitoring system.

Request service:

This indicator shows that the routine service is due. The display of the icon is controlled by the time entry in the **REMINDER INTERVAL** dialog box and it appears after the reminder message has been confirmed.

Enabling/disabling the keypad lock

This input dialog box allows the keypad lock to be enabled or disabled. At the factory, the keypad lock is preset to the standard code 0000.

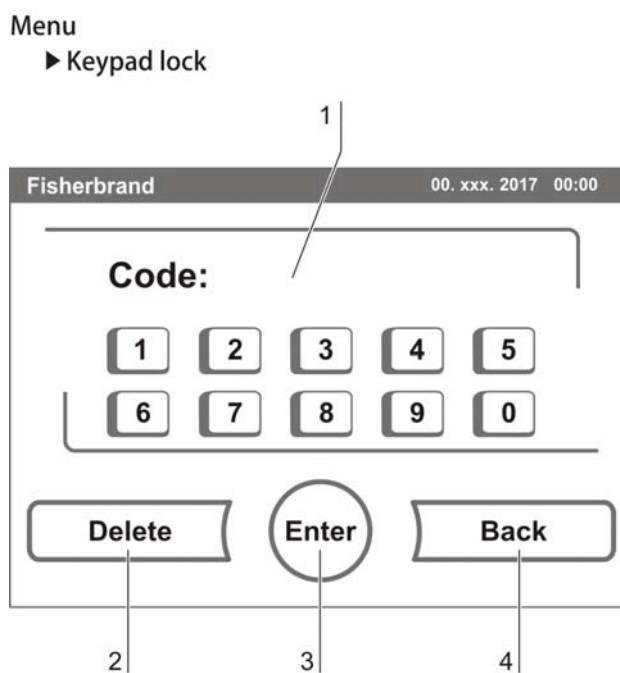

Figure 42. Enabling/disabling the keypad lock

1. Enter the 4-digit code using the keypad. The input appears encrypted in the display [1].
2. To delete complete incorrect input:
 - Press the **DELETE** key [2].
3. To break off the input:
 - Press the **BACK** key[4].

The system returns to the Configuration menu.

4. To confirm the input:
 - Press the **ENTER** key [3].
 - The system returns to the Configuration menu.

NOTE**Changing an existing code:**

The currently valid code can be redefined in the Keypad Lock Code dialog box of the Settings/Setup menu (see “Options” on page 69).

Resetting the code:

If the keypad lock code is no longer available, the code must be reset to the standard code by the Technical Support of Thermo Fisher Scientific.

Software versions

This menu shows the unit software versions in the display [1].

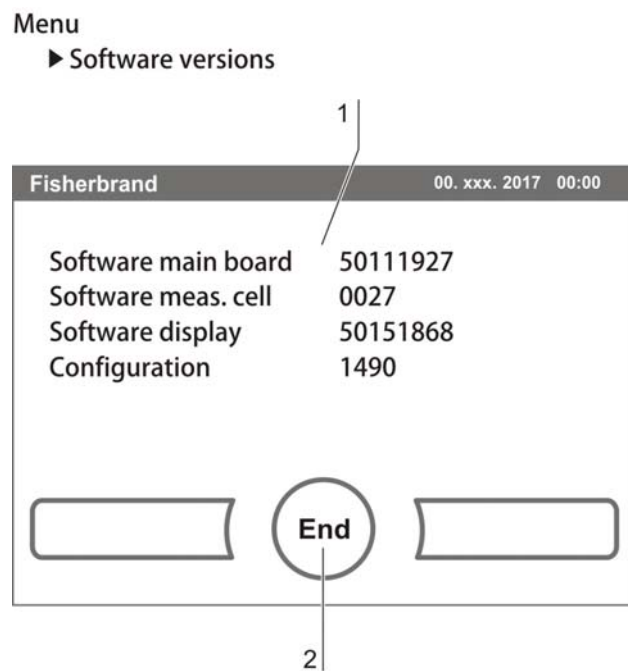

Figure 43. Software versions

- To exit the display:
 - Press the **END** key [2].
 - The system returns to the Configuration menu.

Error messages

The error detection system is an integral element of the device-internal control system. It monitors the control loops and their sensors. If an error is detected in the system, the alarm relay switches and issues the following signals and messages:

- An audible alarm sounds,
- a flashing warning triangle [1] is displayed in the main menu; the value indicators are no longer updated,
- the detected error is listed in the error table,
- the event is entered into the event display.

Response to an error message event

If the alarm relay was switched due to a user action, the switching state can be reset by accepting the error message (e.g. for the manual cancellation of the 90°C decontamination routine).

If the alarm relay was switched due to a technical defect, the switching state remains active until the defect has been corrected (e.g. low water level in work space).

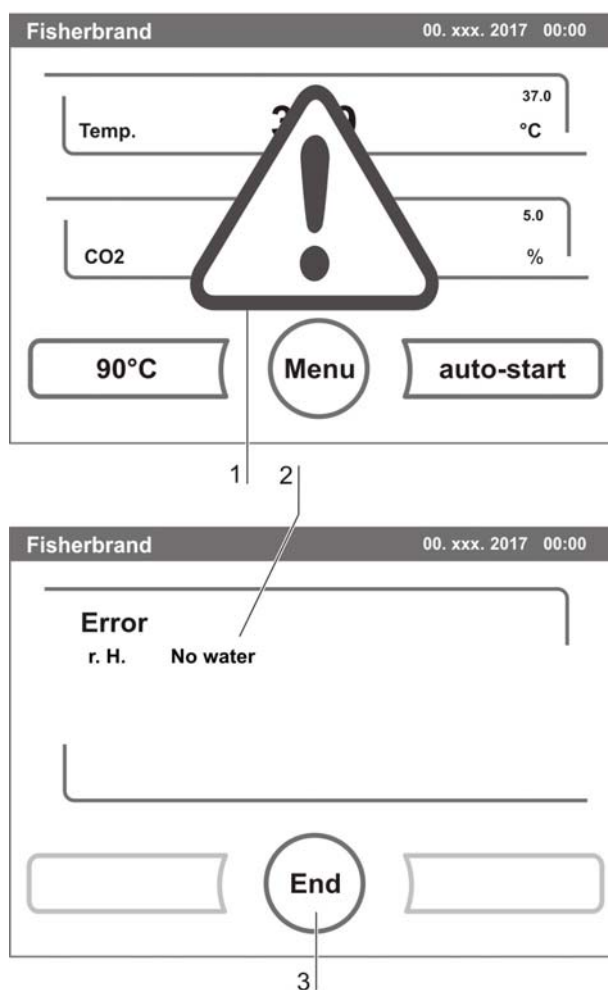

Figure 44. Event error messages

1. To accept the failure message:
 - Press any position on the touchscreen.
 - The Error dialog box [2] appears and the detected error is displayed,
 - the audible alarm is switched off.
2. To exit the error display:
 - Press the **END** key [3].
 - The error message disappears.

Resetting the overtemperature protection mechanism

If the device control has activated the overtemperature protection mechanism and switched over to emergency control mode, a blinking warning triangle [2] and the icon [1] are displayed in the main menu.

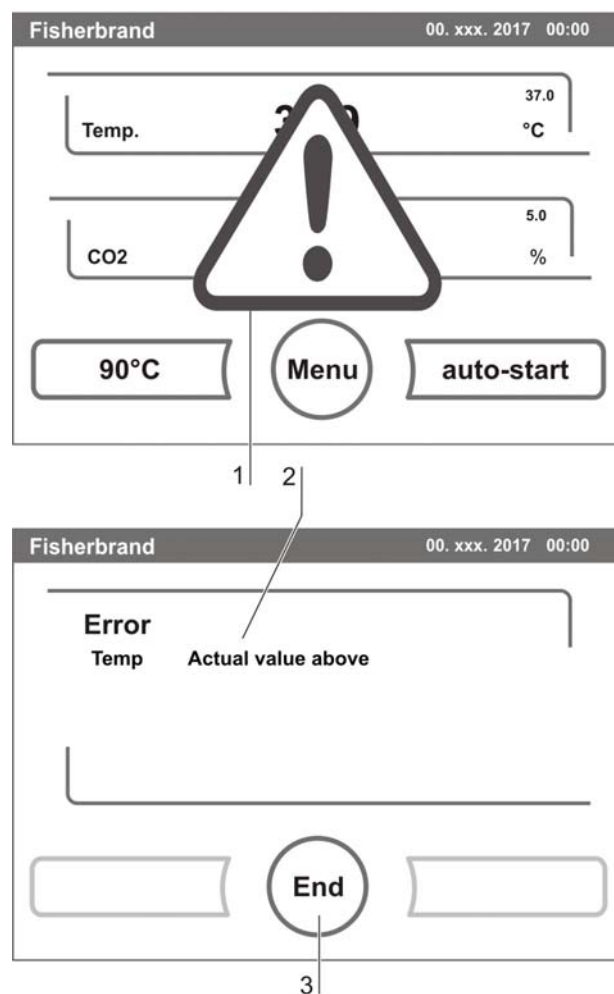

Figure 45. Event error overtemperature

1. 1. To display the fault cause:
 - Touch any position on the touch screen.
 - The Error dialog window [3] opens and the detected fault cause is shown;
 - the acoustic signal is switched off.
2. 2. To close the error display:
 - Press the END [5] key.
 - The error message disappears.
 - The temperature display field [4] is surrounded by a red frame.
3. 3. To reset the error message:
 - Switch off the device.
4. 4. Open the doors and let the work space cool down.
5. 5. Switch on the device.

If the overtemperature protection mechanism is re-activated although the potential fault causes (see error table) have been eliminated, take the device out of service and contact the technical service center.

Troubleshooting

The error tables indicate source of error, cause of error, and possible corrections.

For any communication with the Technical Support of Thermo Fisher Scientific, please have the device data ready.

Error message overview:

Control loop	Error message	Cause	Repair	Alarm relay	Buzzer
System	Device door open too long	Doors open for more than 10 minutes.	Close device doors	x	x
	Failure display	Communication between display and main board	Contact Service when failure is recurring	x	x
	Failure EEPROM main board	EEPROM on main board is faulty.	Contact Service	x	x
	Failure communication mainboard	Communication between display and main board faulty *1)	Contact Service when failure is recurring		
	System - Failure data logger	Failure during recording data logger. Device is still working.	Reset device to cancel failure. When failure is recurring contact Service.		x
	Failure 90°C	Failure in 90°C routine	Reset device to cancel failure. When failure is recurring contact Service.	x	x
	System - Power down during 90°C routine	Power failure during 90°C routine	Reset device and start 90°C routine again.	x	x
	Failure upon auto-start	Failure during auto-start routine	Reset auto-start. When failure is recurring contact	x	x
	System - Safety circuit active	Temperature signal plausibility doubtful *2)	Reset device. When failure is listed several times, contact Service.		
Temperature	Sensor breakage	Detected value is out of limit.	Contact Service	x	x
	Actual value above	Act. val. > nom. val. + 1°C *3)	Do not exceed ambient temperature limit	x	x
	Actual value below	Act. val. < nom. val. - 1°C *4)	Contact Service	x	x
	Calibration values too high / too low	Temperature max. adjustment value exceeded	Contact Service	x	x
	Actual value plausibility doubtful	Temperature signal plausibility doubtful	Contact Service	x	x
	Failure communication\	Measuring cell cannot communicate with	Contact Service	x	x

*1) Error message will be displayed, but not entered in error table.

*2) Error message will be displayed, but not entered in error table.

*3) If failure is detected, a special sample protection controlling will be enabled. To indicate the start of this routine, the icon overtemperature is displayed. The routine will be disabled after a power reset.

*4) After changing the set value, error time will be set on 159 min., after door opening on 45 min.

Error message overview:

Control loop	Error message	Cause	Repair	Alarm relay	Buzzer
Temperatur	Failure LM75	LM75 sensor cannot not communicate with mainboard	Contact Service	x	x
	Failure EEPROM sensor	NV-RAM sensor faulty	Contact Service	x	x
CO ₂	Sensor breakage	Detected value is out of limit.	Reset auto-start. When failure is recurring contact	x	x
	Actual value above	Act. val. > nom. val. + 1% *4)	Check gas supply. Reduce prepressure to 1 bar max.	x	x
	Actual value below	Act. val. < nom. val. - 1% *4)	Check gas supply. Change gas cylinder. Raise prepressure to 1 bar max.. Check supply line to device.	x	x
	Calibration values too high / too low	Max. adjustment value exceeded for CO ₂	Contact Service	x	x
	Failure communication	Measuring cell cannot communicate with	Contact Service	x	x
	No gas	Both CO ₂ gas cylinders are empty	Change at least 1 CO ₂ gas cylinder	x	x
	Failure EEPROM sensor	NV-RAM sensor error.	Contact Service	x	x
rH	No water	Water level in the incubator under	Fill in water or if the auto-start routine is to be run dry (without water), the water level sensor can be switched off.	x	x

*4) After changing the set value, error time will be set on 159 min., after door opening on 45 min.

Shut-down

Shutting the device down



CAUTION:

Contamination hazard!

If the work space surfaces are contaminated, germs can be transferred to the environment of the device.

In case of a shut-down, the device must be decontaminated!

1. Remove the culture containers and all accessories from the work space.
2. Pump the water out off the water reservoir (see chap. 9).
3. Fill in 350 ml water and start the 90°C decontamination routine.
4. Turn the device off using the power switch when the 90°C decontamination routine has been completed.
5. Unplug the power connector and protect it against accidental reconnection.
6. Close the CO₂ supply system shut-off valves.
7. Disconnect the gas pressure hoses from the sleeve at the rear of the device.
8. Clean the work space and wipe the device dry.
9. Until the device is shut down, the work space must be continuously ventilated. Leave the glass door and the outer door open and secure them in this state.

Cleaning and disinfection

Cleaning

NOTICE

Incompatible cleaners!

Some device components are made of plastic. Solvents can dissolve plastics. Strong acids or caustic solutions can cause to become brittle of the plastic.

For cleaning plastic components and surfaces, do not use solvents that contain hydrocarbons, solvents with an alcohol content of more than 10% or strong acids or caustic solutions.



Moisture-sensitive components!

Do not spray cleaning agent onto the touchscreen and the control box at the rear of the device. When wiping the device clean, always make sure that moisture does not enter into these components.

Cleaning exterior surfaces:

1. Remove dirt residues and depositions thoroughly using a solution of water and commercial detergent.
2. Wipe the surfaces clean using a clean cloth and clear water.
3. Then, wipe the surfaces dry using a clean cloth.

Cleaning display:

NOTICE

Moisture-sensitive display!

Do not spray or wipe the display with cleaner.

- Clean display using a dry cloth of 100% micro fiber!

Decontamination procedures

The operator must prepare hygiene regulations for the decontamination of the device in accordance with the application of the device.

The following disinfection procedures are compatible with the device:

Wipe/spray disinfection:

The wipe/spray disinfection is used as the standardized manual disinfection procedure for the device and for all accessories.

90°C decontamination routine:

The 90°C decontamination routine uses an automated program cycle to decontaminate the complete work space including the shelf system and the sensors.

Wipe/spray disinfection

The manual wipe/spray disinfection is carried out in three stages:

- Predisinfection,
- cleaning,
- final disinfection.



CAUTION:

Alcoholic disinfectants!

Disinfectants with an alcohol content of more than 10% may form, in combination with air, easily combustible and explosive gas mixtures. When using such disinfectants, avoid open flames or exposure to excessive heat during the entire disinfection process!



- Use such disinfectants only in adequately ventilated rooms.
- After the disinfectant has been allowed to react, wipe the cleaned device components thoroughly dry.

Observe safety regulations to avoid fire and/or explosion hazard caused by alcohol-containing disinfectants.

Chloride-containing disinfectants!



Chloride-containing disinfectants can corrode stainless steel.

- Use only disinfectants that do not affect stainless steel!

Preparing the manual wipe/spray disinfection:



WARNING

Electric shock!

	 WARNING	Decontamination or cleaning agents
Thermo Fisher Scientific or his agent is to be consulted if there is any doubt about the compatibility of decontamination or cleaning agents.		



Contact with current-carrying components may cause a lethal electric shock.
Prior to cleaning and disinfection work, disconnect the device from the power supply!

- Turn the device off using the power switch.
- Unplug the power connector and protect it against accidental reconnection.
- Check to see if the device is deenergized.



Health hazard!

The surfaces of the work space may be contaminated. Contact with contaminated cleaning liquids may cause infections.
Disinfectants may contain harmful substances.

When cleaning and disinfecting, always observe the safety instructions and hygiene regulations!



- Wear safety gloves.
- Wear safety goggles.
- Wear mouth and respiratory system protection gear to protect the mucous membranes.
- Observe the safety instructions of the manufacturer of the disinfectant and of the hygiene experts.

Predisinfection:

1. Remove all samples from the work space and store them in a safe place.
2. Pump the water off and remove water residues using a cloth.
3. Spray disinfectant onto the surfaces of the work space and of the accessories or wipe the surfaces clean using disinfectant.

NOTICE

Moisture-sensitive components!

Do not spray disinfectant onto the CO₂ sensor in the measuring cell baseplate.

4. Allow the disinfectant to react as specified by the manufacturer.

Removing accessories and shelf system:

1. Remove the entire shelf system from the work space.
For removal and installation of the shelf system, please refer to Section 5.2.
2. If required, remove the blower wheel and its cover from the baseplate of the measuring cell.
The wheel and the cover can be autoclaved.

Removing blower wheel and cover:



WARNING

Electric shock!

Contact with current-carrying components may cause a lethal electric shock. Prior to removing the blower wheel, switch the device off and disconnect it from the power supply system.

1. Remove the two retaining screws of the cover using the supplied Allen wrench (3 mm) and remove the cover.
2. The blower wheel is secured to the axle by a set screw. Remove the set screw using the Allen wrench (2 mm) and pull the blower wheel off.

Cleaning the work space and accessories:

1. Thoroughly remove dirt residues and deposits using a solution of tepid water and dishwashing agent.
2. Wipe the surfaces clean using a clean cloth and plenty of clear water.
3. Remove the cleaning liquid from the water tray and wipe all surfaces of the work space thoroughly dry.
4. Wipe accessories thoroughly dry.

Final disinfection:

1. Spray disinfectant again onto the work space, the shelf system, and the removed components and wipe them clean.
2. Allow the disinfectant to react as specified by the manufacturer.
3. Reinstall the shelf system and the removed components.

NOTE

Functional check:

After the installation, check to see if the blower wheel is securely attached to the axle and if it can rotate freely, then secure cover using the screws.

90°C decontamination routine

The entire program run of the decontamination routine takes approximately 25 hours.

During this routine, a hot and humid atmosphere at 90 °C with highly decontaminating effect is created in the work space. The effectiveness of the 90°C decontamination routine has been certified by independent institutes. Information on these tests is available from Thermo Fisher Scientific upon request.

After the run has been completed, the device must be started up again using the auto-start routine.

NOTE

Conditions that prevent the start of the 90°C decontamination routine:

The 90°C routine cannot be started if one of the following failure conditions exists.

Temperature control loop:

- **Sensor breakage,**
- **actual value above set value (excessive deviation),**
- **actual value below set value (excessive deviation),**
- **set value not plausible,**
- **calibration values too high or too low,**
- **sensor communication failure,**
- **sensor parameter not plausible,**
- **no communication with LM 75.**

Control loop for CO₂ gas supply:

- **No communication with sensor.**

In this case, the 90°C key is dimmed and its function is not available.

Overtemperature protection:

If the overtemperature protection was enabled on the device, the 90°C decontamination routine cannot be started before the fault has been corrected or reset.

Procedure of a 90°C decontamination routine:

1. After cleaning, reinstall the shelf system components into the work space.
2. Fill the floorpan with 350 ml processed water.
3. Turn the device on using the power switch.

4. Activate and start the decontamination routine.
5. After the decontamination routine has been completed, remove the remaining water using a sterile cloth.
6. Turn the device off or resume operation.



CAUTION:

Hot surfaces!



The handle and the screen of the glass door, the interior panel of the outer door as well as the surfaces of the shelf system and of the work space become extremely hot during the 90°C decontamination routine.

During the routine run or immediately after completion of the run, always wear safety gloves when touching these surfaces!

NOTICE

Damage to the samples!

During the 90°C decontamination routine, the work space is heated up to 90 °C.

Make sure that:

- all samples are removed from the work space,
- all accessories are removed from the work space.

Operating phases of 90°C decontamination:

The remaining run time of the 90°C decontamination routine describes the time between the start or the current time status to the end of the drying phase. The indicated remaining run times are not measured values but merely used for orientation.

The routine is divided into five phases:

1. Heating phase,
2. decontamination phase,
3. condensation,
4. cool-down,
5. drying.

Heating phase: Remaining run time approx. 25 hours.

The work space is heated to a temperature of 90° C while an elevated relative humidity is created.

Decontamination phase: Remaining run time approx 23 hours.

After the decontamination atmosphere has been created, the decontamination phase of approx. 9 hours is started. The temperature is maintained at 90°C.

Condensation: Remaining run time approx. 14 hours.

The floor heating is switched off, the temperature is maintained only by the sidewall heating. This function is activated to reduce the created moisture before the cool-down and to collect it at the work space floor.

Cool-down phase: Remaining run time approx. 8 hours.

The device cools down until the originally set temperature set value is reached.

Postheating phase: Remaining run time approx. 1 hour.

During the postheating phase, condensate within the device is eliminated as far as possible; remaining condensate accumulates at the bottom of the work space.

.End of the decontamination routine: Remaining run time 0 hours.

When the remaining run time has elapsed to 0 hours, the device has reached the originally set working temperature again (e.g. 37 °C). The 90°C decontamination routine must then be stopped by pressing the appropriate key.

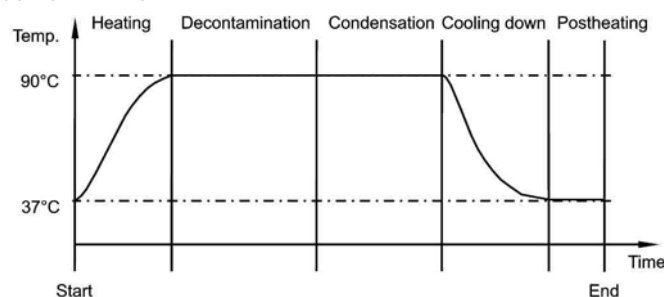

Figure 46. Decontamination routine phases

Activating the 90°C routine

The 90°C decontamination routine is used to decontaminate the complete work space.

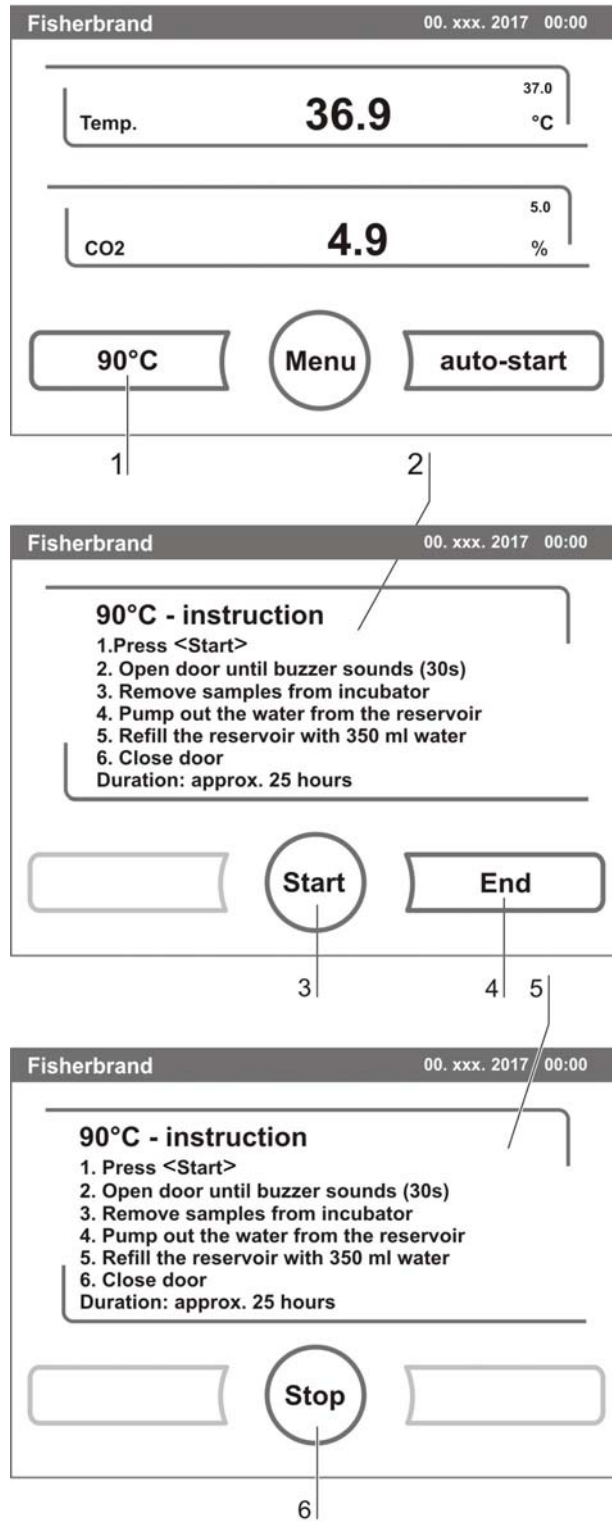

Figure 47. Activating the 90°C routine

1. Press the **90°C** key [1].
 - The 90°C-instruction menu [2] is displayed.
2. To exit the 90°C-instruction menu and 90°C:
 - Press the **END** key [4].
 - The system returns to the main menu.
3. To activate the 90°C routine:
 - Press the **START** key [3].
 - The 90°C-instruction menu [2] is displayed.
4. To air the work space, open both device doors when the audible alarm sounds after 30 seconds.
5. Remove all samples from the work space.
6. Pump the water out of the floorpan and wipe off water residues.
7. Fill the floorpan of the work space with 350 ml processed water.
8. Close both device doors.
 - The run of the 90°C decontamination routine starts.
 - **Fig. 48:** While the 90°C decontamination routine is running, the display shows the current status [5] and outputs the following information:
 - Temperature,
 - start time,
 - phase,
 - remaining run time.

Interrupting the 90°C routine

The 90°C decontamination routine can be interrupted at any time.

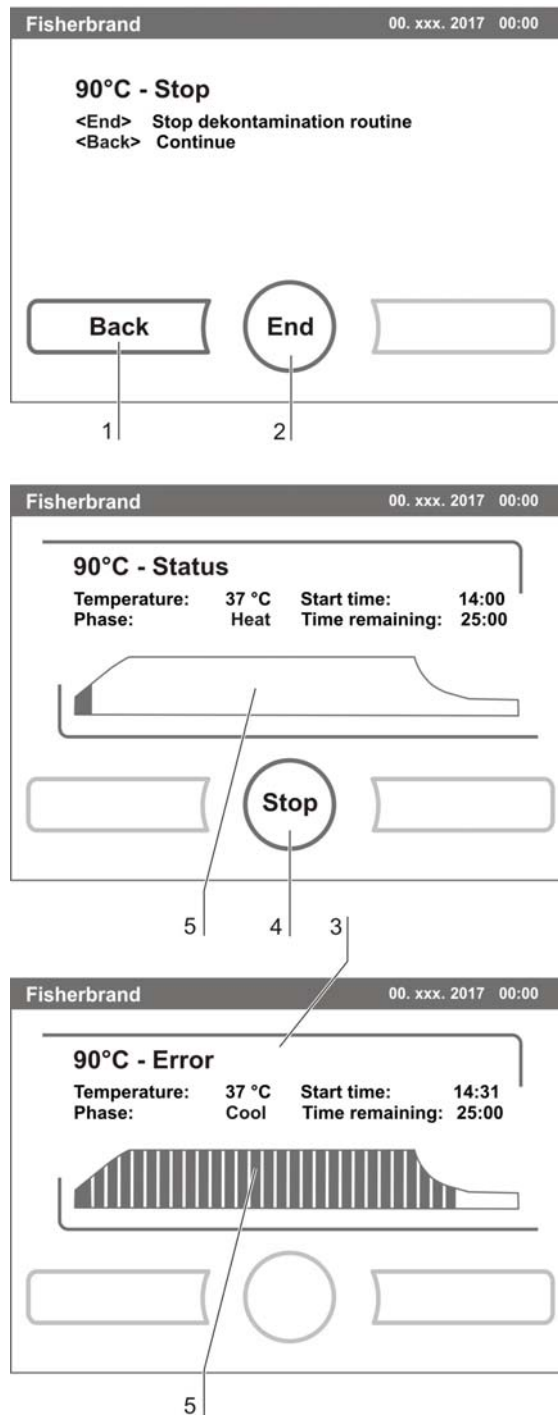

Figure 48. Interrupting / canceling 90°C

1. To interrupt the 90°C routine:

- Press the **STOP** key [6].

If the **STOP** key is pressed, the routine is interrupted and the 90°C Stop dialog box is opened as a security request. The routine can now be ultimately canceled or resumed.

2. To cancel the 90°C routine:

- Press the **END** key [2].
- The error message is displayed.
- If the error message is confirmed, the system returns to the main menu.

3. To resume the 90°C routine:

- Press the **BACK** key [1].
- The system returns to the status display, and the decontamination routine is resumed.

4. To interrupt the 90°C routine from the status display:

- Press the **STOP** key [4].
- The 90°C routine Stop dialog box is displayed as a security request (see above). Proceed with work step 2. (see section above).

90°C routine interruption due to error

If an error occurs while the decontamination routine is run, an error message [3] is displayed and the following actions are initiated:

- The decontamination routine automatically changes to the cool-down phase,
- the audible alarm sounds.

1. To confirm the audible alarm:

- Press any position on the display.
- The audible alarm is switched off. The **END** key is displayed.
- If the decontamination routine is not canceled after this, cool-down to the set temperature occurs.

2. To cancel the 90°C routine:

- Press the **END** key [2].
- The error message is displayed.
- If the error message is confirmed, the system returns to the main menu.

Completing the 90°C routine

After the five phases have been completed, the Stop **90°C decontamination routine** dialog box [1] is displayed.

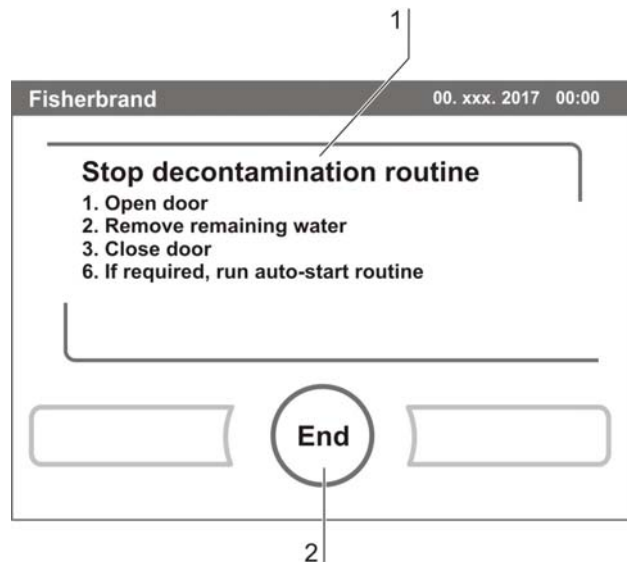

Figure 49. 90°C decontamination routine completion

The decontamination routine must be stopped manually.

- To stop the 90°C routine:
 - Press the **END** key [2].
 - The system returns to the main menu.

NOTE

Opening door during 90°C decontamination:

If the door will be opened and closed again whilst 90°C decontamination is running, the routine returns to a phase which will ensure a continuation without faults.

Maintenance

Inspections and checks

To ensure the operativeness and the operational safety of the device, the functions and device components listed below must be checked at different intervals.

Daily check:

- Gas supply of the CO₂ supply system.

Annual inspection:

- Tightness of the glass door seal.
- Permeability of the pressure compensation opening with insert.
- Functional check of the operating panel and of the device control.
- Electrical safety check in accordance with the relevant national regulations.

NOTE

Functional check:

If safety devices were removed or disabled for inspections, the device must not be operated before the safety devices have been reinstalled and checked for their correct function.

Service intervals

During running operation, the following service works must be performed:

3-month service:

- Run auto-start routine and 90°C decontamination routine,
- perform temperature and CO₂ comparison measurement.

Annual service:

- Replace gas inlet filter.
- Perform Technical Service service inspection.

NOTE

Service contract:

Thermo Scientific offer a device-specific service contact that comprises all test and service works required.

Preparing the temperature calibration

To determine the exact measured value of the device-integral temperature sensor, a temperature comparison measurement has to be performed every three months.

If a major temperature deviation is found during this check, a temperature calibration is required.

During this process, the temperature control of the device is set to the value measured during the temperature comparison measurement.

Use a calibrated measuring instrument with an accuracy of $> \pm 0.1^{\circ}\text{C}$ for this test. To minimize temporary temperature fluctuations during the measurement, the measuring instrument is placed into the work space in an isothermal container (e.g. a bowl filled with glycerol). The center of the work space is the reference location for the comparison measurement.

NOTE

Isothermal container:

Fisher Scientific offer a device-specific service contact that comprises all test and service works required.

Do not use a container filled with water as isothermal container as the evaporation of water will result in a lower temperature reading.

Excessive work space temperature:

Excessive work space temperature after the calibration can be reduced by leaving the doors open for approx. 30 seconds.

Comparison measurement procedure:

Figure 50. Preparing the temperature calibration

1. Turn the device on using the power switch.
2. Set the temperature set value and allow the device to be heated. This may take up to several hours.
3. Place the measuring instrument [3] onto the center area of the work space.
4. Alternatively, a temperature sensor may be positioned in this location. Route the connecting cable either through the measurement opening [2] in the glass door or through the access port [1] in the rear panel of the device.
5. Close the doors.
6. Wait until the temperature value displayed on the measuring instrument has stabilized.
7. Calibrate the temperature control as described in “Temperature calibration procedure” on page 100.

Temperature calibration procedure

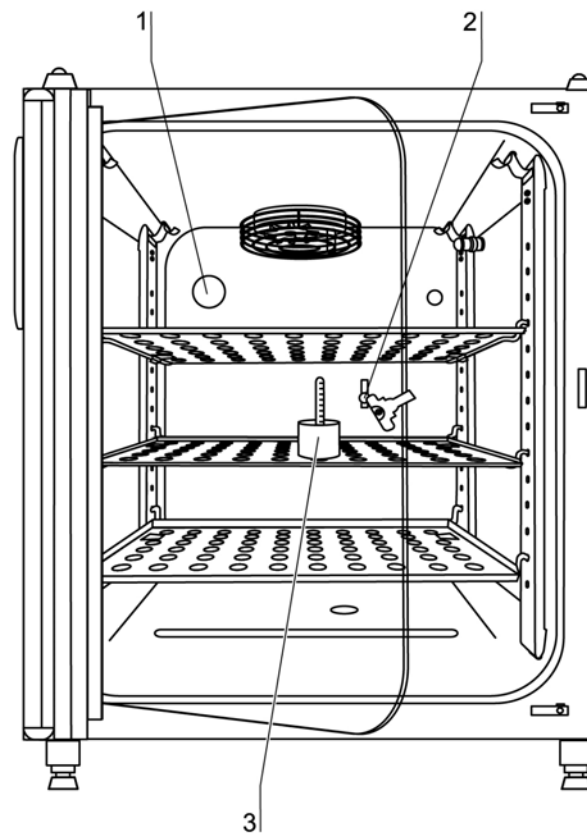
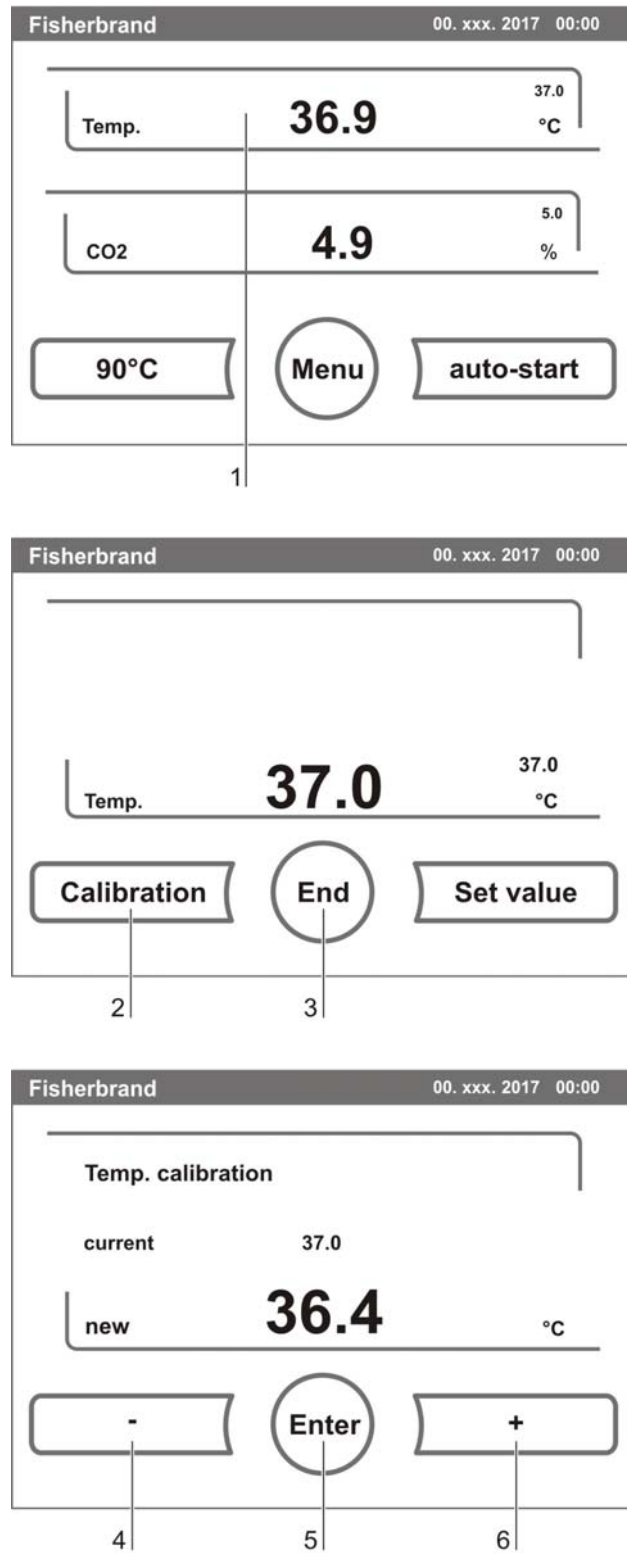

Figure 51. Temperature calibration procedure

Measurement example:

- Temperature set value: 37 °C

Reference temperature: 36.4 °C

1. Press **TEMPERATURE DISPLAY** [1].
 - The temperature menu is displayed.
2. To exit the temperature menu:
 - Press the **END** key [2].
3. To enter the Calibration submenu:
 - Press the **CALIBRATION** key [2].
4. Enter the measured value (targeting value):
 The targeting value can be increased or reduced in increments; if you keep the + key [4] or the – key [6] depressed, the function switches to a rapid increase/reduction; after approx. 3 seconds, another increase/reduction occurs.

 To increase the targeting value:
 - Press the + key [6].
 To reduce the set value:
 - Press the – key [4].
5. To accept and store the targeting value:
 - Press the **ENTER** key [5].
 - The system returns to the main menu. The temperature display shows the current actual value measured in the work space.

NOTE**Excessive work space temperature:**

Excessive work space temperature after the calibration can be reduced by leaving the doors open for approx. 30 seconds.

Value reset:

If the value isn't changed within the next 30 seconds, the system automatically exits the menu, and the most recently confirmed value is preserved.

Preparing the CO₂ calibration

To determine the exact measured value of the device-integral CO₂ sensor, a CO₂ comparison measurement has to be performed every three months.

If a major deviation is found during this check, a CO₂ calibration is required.

During this process, the CO₂ control of the device is set to the value measured during the comparison measurement.

Use a calibrated measuring instrument with an accuracy of $\pm 0.3\%$ CO₂ for this test.

Suitable instrument:

- Portable IR readout instrument.

The measuring sample is withdrawn through the sealable measurement opening of the glass door. The comparison measurement must be performed when the device is completely heated up.

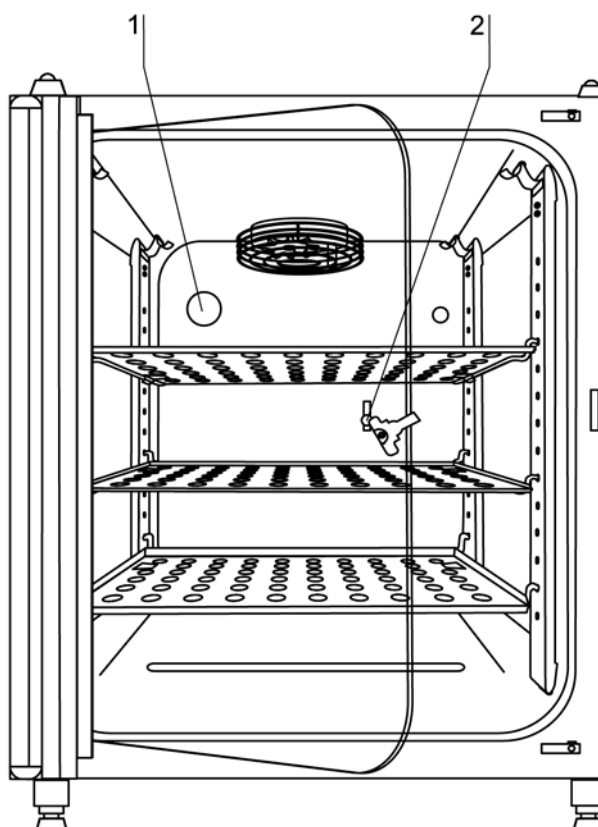

Figure 52. Preparing CO₂ calibration

Comparison measurement procedure:

1. Turn the device on using the power switch.
2. Set the CO₂ set value and start the device with auto-start.
3. Insert the measuring instrument probe through the measurement opening [2] into the work space. Wait until the CO₂ value displayed by the instrument has stabilized.

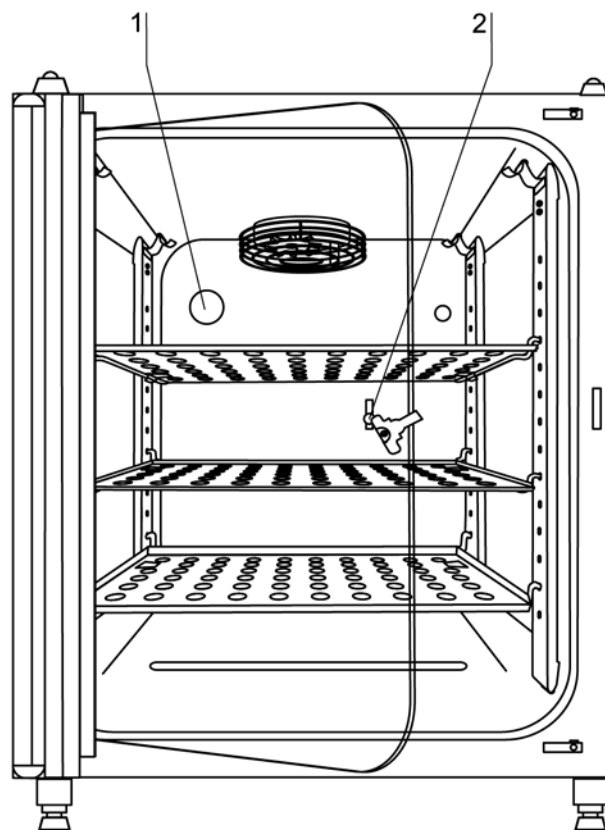

Figure 53. Measurement opening

4. Remove the measuring probe, plug the measurement opening and close the doors.
5. Calibrate the CO₂ control.

NOTE**IR measuring cell:**

For devices with infrared (IR) measuring cells, the CO₂ calibration can only be performed when the CO₂ concentration has been set to 4.0% or more.

Calibration should be performed with the CO₂ set value designated for the work process (prospective work process value).

CO₂ calibration procedure

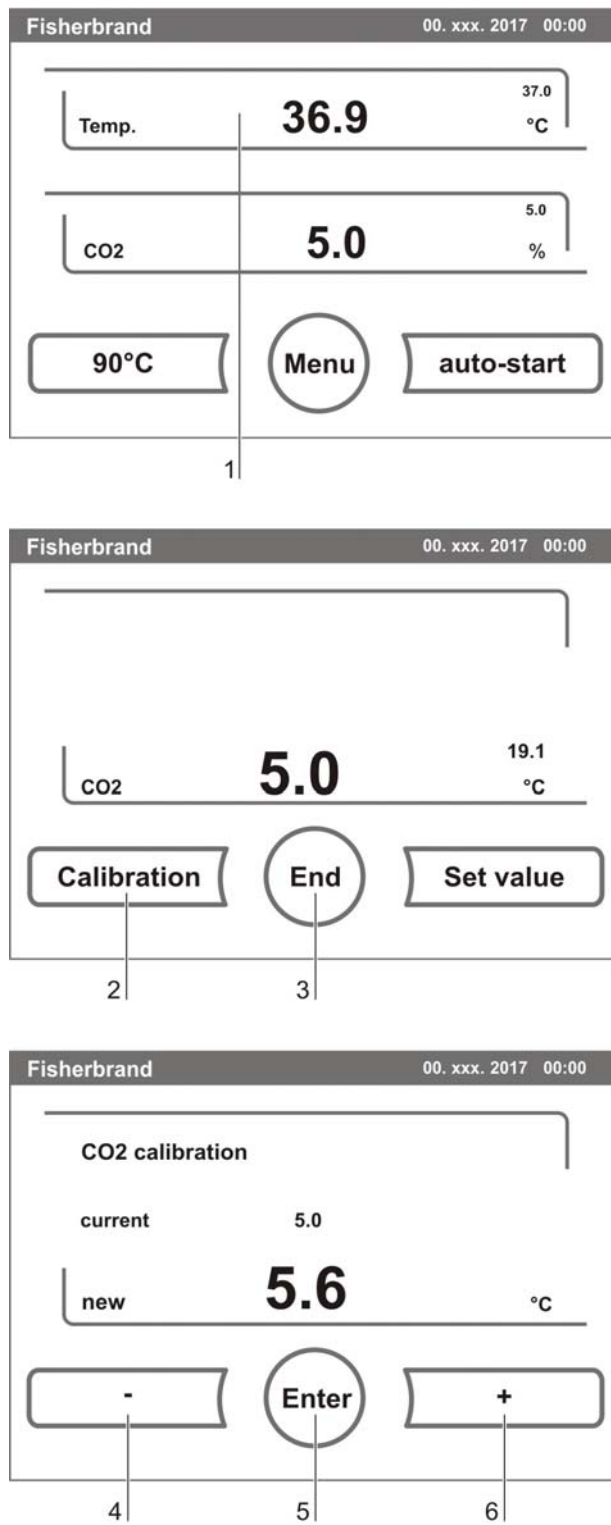

Figure 54. CO₂ calibration procedure

Measurement example:

- CO₂ set value: 5%

Reference temperature: 5.6%

1. Press the CO₂ **DISPLAY** key [1].
 - The CO₂ menu is displayed.
2. To exit the CO₂ menu:
 - Press the **END** key [3].
3. To enter the Calibration submenu:
 - Press the **CALIBRATION** key [2].
4. To enter the measured value (targeting value):
 The targeting value can be increased or reduced in increments; if you keep the + key [4] or the – key [6] depressed, the function switches to a rapid increase/reduction; after approx. 3 seconds, another increase/reduction occurs.

 To increase the targeting value:
 - Press the + key [6].
 To reduce the set value:
 - Press the – key [4].
5. To accept and store the targeting value:
 - Press the **ENTER** key [5].
 - The system returns to the main menu. The temperature display shows the current actual value measured in the CO₂ display.

NOTE**Excessive CO₂ content:**

Excessive CO₂ content after the calibration can be reduced by leaving the device doors open for approx. 30 seconds.

Value reset:

If the value isn't changed within the next 30 seconds, the system automatically exits the menu, and the most recently confirmed value is preserved.

Replacing the gas inlet filter

The gas inlet filter (CO₂-supply) has plastic threads and is screwed by hand into the threaded hole at the control box.

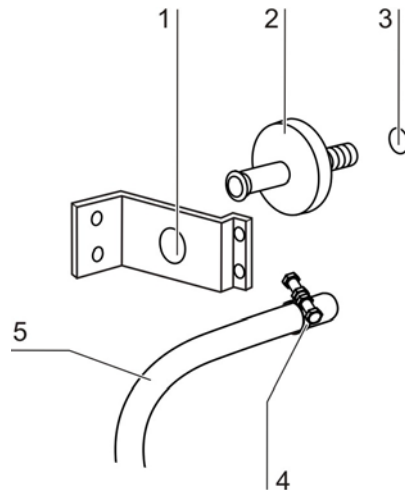

Figure 55. Gas inlet filter installation

Procedure for gas supply gas inlet filter:

1. Make sure that the gas supply is shut off.
2. Loosen the hose clamp [4].
3. Remove the gas hose [5] from the sterile filter sleeve [2].

Procedure for all gas inlet filters:

4. Remove the retainer [1].
5. Unscrew the gas inlet filter [2] from the threaded hole [3].
6. When installing the new gas inlet filter, make sure that the plastic thread is not canted. Install the filter using caution.
7. Install the retainer [1].

Procedure for gas supply gas inlet filter:

8. Connect the gas hose to the gas inlet filter sleeve and secure it using the hose clamp. Check to see if the gas hose is securely seated on the sleeve.

Replacing the device fuses

The two identical device fuses [4] are installed in the fuse compartment [1] next to the power plug receptacle of the device:

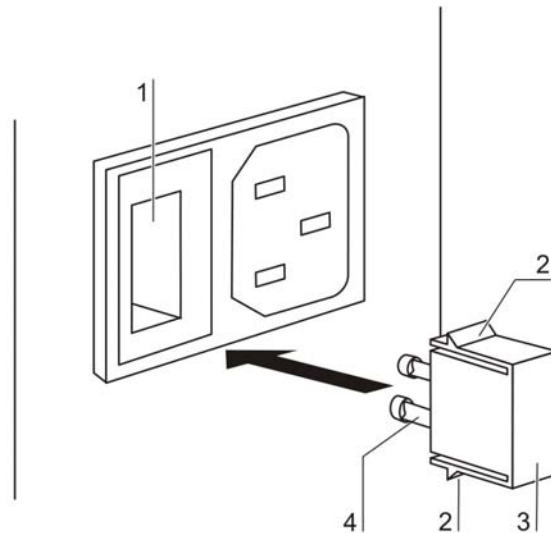

Figure 56. Device fuse replacement

- Time delay fuses, 6.3 A (5x20 mm)

1. The fuse holder is secured to the fuse compartment [1] using two locking tabs [2].
2. To remove the fuse holder, squeeze the two locking tabs and pull the holder [3] out of the fuse compartment.
3. Remove the faulty fuse from the fuse holder and install the new fuse.
4. Slide the fuse holder into the fuse compartment and press the holder on until the locking tabs are fully engaged.

Replacing the door seal

The door seal (magnetic seal) [3] of the outer door is located in the retaining slot. No tools are required to replace the seal.

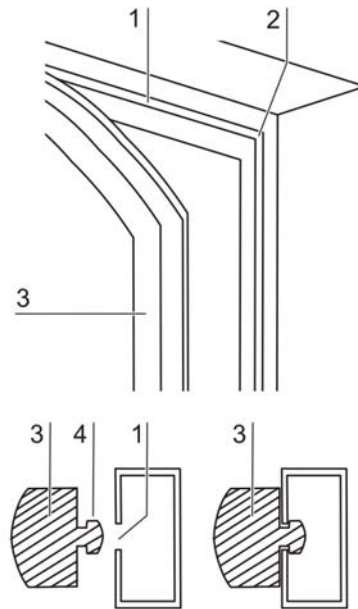

Figure 57. Magnetic door seal replacement

1. Pull the magnetic seal [3] out of the guide slot [1].
2. Position the new seal at a corner [2] and press the seal retaining rail [4] into the slot.
3. Make sure that the retaining rail taper is positioned correctly in the slot [1] and that the seal is flush with the door frame.

Disposal



WARNING

Contamination hazard!

The device may have been used for treating and processing infectious substances. Therefore, the device and device components may have been contaminated. Prior to disposal, all device components must be decontaminated.

- Clean the device components thoroughly and either disinfect or decontaminate them (depending on application).
- Attach a declaration of non-objection with details of performed decontamination measures to the items that are to be disposed of.

All device components can be disposed of after they have been decontaminated properly.

NOTE

Recycling Service

Thermo Fisher Scientific offer a recycling service for discarded components at the owner's expense.

Overview of the materials used:

Component	Material
Thermal insulation components	Polystyrene foam EPS/PPS-Compound
Printed circuit boards	Enclosed electrical components coated with different plastics, equipped on epoxy resin-
Plastic components, general	Note material labelling
Exterior housing	Galvanized steel sheet, painted
Device rear panel	Galvanized steel sheet
Outer door	Galvanized steel sheet, painted
Door inner panel	Galvanized steel sheet, painted
Operating panel and indicator foil	Polyethylene
Magnetic door seal	Magnetic core sheathed with EMPP
Heating	Silicone-sheathed resistance-type wires
Interior containers, installed components and	Stainless steel 1.4301 or copper
Plug for pipe channel	Silicone
Pressure compensation opening insert	POM with brass sinter filter
Glass screen	Soda-silicate glass
Glass door seal, measurement opening	Tempered silicone
Sensor block	Stainless steel 1.4301
Blower wheel	Stainless steel 1.4305 or copper
Measuring cell base plate seal	Tempered silicone
Cables	Plastic-sheathed copper flexible
Packaging	Corrugated board, polyethylene film, and

Technical data

Description	Unit	Value
Mechanical		
External dimensions (W x H x T)	mm	637 x 867 x 782
Interior dimensions (W x H x T)	mm	470 x 607 x 530
Chamber volume	l	approx 151
Shelves (W x T)	mm	423 x 465
Standard quantity	Piece	3
Maximal quantity	Piece	10
Maximal surface load	kg	10 / insertion shelf
Maximal device overall load	kg	30
Weight, without accessories	kg	70
Thermal		
Thermal safety devices according to DIN 12880:2007-05		Class 3.1 (overtemperature controller (TWW) with overtemperature detection function)
Ambient temperature range	°C	+18...33
Temperature control range	°C	RT + 3 ... 55
Temperature deviation, time (DIN 12880, Part 2)	°C	± 0.1
Temperature deviation, spatial (DIN 12880, Part 2) at 37 °C *1)	°C	± 0.5
Duration of the auto-start routine, to 37 °C ambient temperature 20 °C	h	5 ... 10
Heat transfer to environment: at 37 °C during 90°C decontamination	kWh/h kWh/h	0.06 0.112
Humidity		
Water quality		demineralized / distilled or autoclaved or completely deionized / distilled or autoclaved
Description		
Unit		
Value		
Liquid quantity: Incubation operation 90°C disinfection operation	l ml	max. 3.0 / min 1.2 350
Constant humidity at 37 °C (high-humidity mode)	% rH	approx 93
Constant humidity at 37 °C (low-humidity mode)	% rH	approx 90
Others		
Sound pressure level (DIN 45 635, Part 1)	dB(A)	< 50
Relative humidity of environment	% rH	max. 80
Location elevation	m ASL	max. 2000

*1) determined on the basis of DIN 12880 for devices with standard equipment. See detailed information in calibration

Description	Unit	Value
CO₂ gas supply system		
Gas purity	%	min. 99.5 or medical quality
Prepressure	bar	min. 0.8 - max. 1
Measuring and control range	% vol.	0... 20
Control deviation, temporal	% vol.	± 0.1
CO₂ measuring cell		
Accuracy (absolute)	% CO ₂	± 0.3
Electrical system		
Rated voltage	V V	1/N/PE 230 V, AC (± 10%) 1/N/PE 120 V, AC (± 10%)
Rated frequency	Hz	50/60
Interference suppression (DIN VDE 0875)		Interference level N
Type of protection (DIN 40 050)		IP 20
Protection class		I
Overvoltage category (EN 61010)		II
Pollution severity (EN 61010)		2
Rated current	A	2.5 (230 V, AC) 5.2 (120 V, AC)
On-site fusing: Fuse Circuit breaker		T 10 A G 16
Rated input	kW kW	0.58 (230 VAC) 0.62 (120 VAC)
EMC class		B

Device log

Please list carried out works here:

Device type:		Part number:	
Serial number:		Service number:	
Location:		Operator's note:	
Work carried out	Notes	Date	Signature

Ordering Information

Product	Cat. No.
Fisherbrand Isotemp CO ₂ incubator, stainless steel 150L chamber with on-demand 90°C decontamination cycle and thermal conductivity (TC) CO ₂ sensor technology, 120V 50/60 Hz (model 50153428)	11676604
Fisherbrand Isotemp CO ₂ incubator, stainless steel 150L chamber with on-demand 90°C decontamination cycle and infrared (IR) CO ₂ sensor technology, 120V 50/60 Hz (model 50153429)	11676605
Fisherbrand Isotemp CO ₂ incubator, stainless steel 150L chamber with on-demand 90°C decontamination cycle and thermal conductivity (TC) CO ₂ sensor technology, 230V 50/60 Hz (model 50153430)	15660667
Fisherbrand Isotemp CO ₂ incubator, stainless steel 150L chamber with on-demand 90°C decontamination cycle and infrared (IR) CO ₂ sensor technology, 230V 50/60 Hz (model 50153431)	15650667