

Register your instrument!
www.eppendorf.com/myeppendorf



Concentrator plus/Vacufuge® plus

Original instructions

Copyright ©2020 All rights reserved, including graphics and images. No part of this publication may be reproduced without the prior permission of the copyright owner.

Eppendorf® and the Eppendorf Brand Design are registered trademarks of Eppendorf AG, Germany.

Registered trademarks and protected trademarks are not marked in all cases with ® or ™ in this manual.

U.S. Patents are listed on www.eppendorf.com/ip

Table of contents

1	Operating instructions	7
1.1	Using this manual	7
1.2	Danger symbols and danger levels	7
1.2.1	Danger symbols	7
1.2.2	Danger levels	7
1.3	Symbols used	8
1.4	Abbreviations used	8
2	Safety	9
2.1	Intended use	9
2.2	User profile	9
2.3	Application limits	9
2.3.1	Declaration concerning the ATEX directive (2014/34/EU)	9
2.4	Information on product liability	9
2.5	Warnings for intended use	10
2.5.1	Personal injury or damage to the device	10
2.5.2	Incorrect handling of the device	11
2.5.3	Incorrect handling of the rotors	12
2.5.4	Extreme strain on the sample tubes	13
2.5.5	Vacuum	13
2.6	Safety instructions on the device	14
3	Product description	15
3.1	Product overview	15
3.2	Delivery package	17
3.3	Features	17
3.4	Name plate	19
4	Installation	21
4.1	Selecting the location	21
4.2	Preparing installation	22
4.3	Installing the instrument	24
4.3.1	General installation	24
4.3.2	Complete system: Connecting the emission condenser	26
4.3.3	Complete system: Connecting the gel dryer	27
4.3.4	Basic device: Connecting the vacuum pump	28
5	Operation	33
5.1	Operating controls	33
5.2	Possible applications	34
5.3	Preparation for concentration	34
5.3.1	Switching on the device	34
5.3.2	Inserting the rotor	35
5.3.3	Starting the warm-up phase	35
5.3.4	Loading a fixed-angle rotor	36
5.3.5	Loading a swing-bucket rotor	37
5.3.6	Closing the lid of the device	38

Table of contents

Concentrator plus/Vacufuge® plus
English (EN)

5.4	Starting the concentration process	38
5.4.1	Starting the concentration process with time setting	39
5.4.2	Starting the concentration process with continuous run	39
5.4.3	Completing the concentration process	40
5.4.4	Removing the rotor	40
5.4.5	Emptying the emission condenser	40
5.4.6	Switching off the device	40
5.5	User instructions on rotors	41
5.5.1	Rotor A-2-VC	41
5.6	Special function.	42
5.6.1	Starting the desiccator function on the device	42
5.6.2	Starting the centrifuge function on the device	42
5.6.3	Starting the complete system with gel dryer	42
6	Maintenance	43
6.1	Service	43
6.1.1	Device	43
6.1.2	Pump	43
6.1.3	Rotor and accessories	43
6.2	Preparing cleaning/disinfection	44
6.3	Cleaning/disinfection	44
6.3.1	Cleaning and disinfecting the device	45
6.3.2	Cleaning and disinfecting the rotor.	46
6.4	Cleaning glass breakage	46
6.5	Replacing fuses	47
6.6	Decontamination before shipment	47
7	Troubleshooting	49
7.1	General errors	49
7.2	Error messages	50
7.3	Opening the device in case of a mains/power outage using the emergency release	51
8	Transport, storage and disposal	53
8.1	Transport	53
8.2	Storage	53
8.3	Disposal	54
9	Technical data	55
9.1	Power supply	55
9.2	Ambient conditions	55
9.3	Weight/dimensions	55
9.4	Noise level	56
9.5	Diaphragm vacuum pump for the complete system	57
9.6	Application parameters	57
9.7	Service life of accessories	58
9.8	Rotors	58
9.8.1	Fixed-angle rotors	59
9.8.2	Swing-bucket rotor	61
9.8.3	Special notes on the individual rotors	61

10 Ordering information	63
10.1 Fuses	63
10.2 Accessories	63
10.2.1 Rotors	63
10.2.2 Adapters	64
10.2.3 Others accessories	64
 Certificates	 65

Table of contents

Concentrator plus/Vacufuge® plus
English (EN)

1 Operating instructions









1.1 Using this manual

- ▶ Read this operating manual completely before using the device for the first time. Observe the instructions for use of the accessories where applicable.
- ▶ This operating manual is part of the product. Please keep it in a place that is easily accessible.
- ▶ Enclose this operating manual when transferring the device to third parties.
- ▶ The current version of the operating manual for all available languages can be found on our webpage www.eppendorf.com/manuals.

1.2 Danger symbols and danger levels

1.2.1 Danger symbols

The safety instructions in this manual have the following danger symbols and danger levels:

	Risk of crushing		Electric shock
	Hazard point		Toxic substances
	Biohazard		Hot surface
	Explosive substances		Material damage

1.2.2 Danger levels

DANGER	<i>Will</i> lead to severe injuries or death.
WARNING	<i>May</i> lead to severe injuries or death.
CAUTION	May lead to light to moderate injuries.
NOTICE	May lead to material damage.

Operating instructions

Concentrator plus/Vacufuge® plus
English (EN)

1.3 Symbols used

Depiction	Meaning
1. 2.	Actions in the specified order
▶	Actions without a specified order
•	List
<i>Text</i>	Display or software texts
i	Additional information

1.4 Abbreviations used**ETFE**

Ethylene-tetrafluoroethylene copolymer

FFKM

Perfluorelastomer

MTP

Microplate

PCR

Polymerase Chain Reaction

PMMA

Polymethyl methacrylate

PTFE

Polytetrafluorethylene

rcf

Relative centrifugal force : g -force in m/s^2

rpm

Revolutions per minute

UV

Ultraviolet radiation

2 Safety

2.1 Intended use

The Concentrator plus and the Vacufuge plus are intended for sample preparation. They have been designed in particular for the concentration of aqueous solutions of nucleic acids and proteins in approved micro test tubes. The devices may only be operated by trained and skilled personnel and are intended for indoor use only.

2.2 User profile

The device and accessories may only be operated by trained and skilled personnel.

Before using the device, read the operating manual and the instructions for use of the accessories carefully and familiarize yourself with the device's mode of operation.

2.3 Application limits

2.3.1 Declaration concerning the ATEX directive (2014/34/EU)



DANGER! Risk of explosion.

- ▶ Do not operate the device in areas where explosive substances are handled.
 - ▶ Do not use this device to process any explosive or highly reactive substances.
 - ▶ Do not use this device to process any substances which may generate an explosive atmosphere.
-

Due to its design and the environmental conditions inside the device, the Concentrator plus/Vacufuge plus is not suitable for use in a potentially explosive atmosphere.

The device must be used only in a safe environment, such as in the open environment of a ventilated laboratory or a fume hood. The use of substances which could create a potentially explosive atmosphere is not permitted. The final decision on the risks associated with the use of these types of substances is the user's responsibility.

2.4 Information on product liability

In the following cases, the designated protection of the device may be affected. The liability for any resulting damage or personal injury is then transferred to the owner:

- The device is not used in accordance with the operating manual.
- The device is used outside of its intended use.
- The device is used with accessories or consumables that are not recommended by Eppendorf.
- The device is maintained or repaired by persons not authorized by Eppendorf AG.
- The user makes unauthorized changes to the device.

2.5 Warnings for intended use

Read the operating manual and observe the following general safety information before using the device.

2.5.1 Personal injury or damage to the device



WARNING! Electric shock due to damage to the device or mains/power cord.

- ▶ Only switch on the device if the device and mains/power cord are undamaged.
- ▶ Only operate devices which have been installed or repaired properly.
- ▶ In case of danger, disconnect the device from the mains/power supply voltage. Disconnect the mains/power plug from the device or the earth/grounded socket. Use the isolating device intended for this purpose (e.g. the emergency switch in the laboratory).



WARNING! Lethal voltages inside the device.

If you touch any parts which are under high voltage you may experience an electric shock. Electric shocks cause injuries to the heart and respiratory paralysis.

- ▶ Ensure that the housing is closed and undamaged.
- ▶ Do not remove the housing.
- ▶ Ensure that no liquids can penetrate the device.

Only authorized service staff may open the device.



WARNING! Danger due to incorrect voltage supply.

- ▶ Only connect the device to voltage sources which correspond with the electrical requirements on the name plate.
- ▶ Only use earth/grounded sockets with a protective earth (PE) conductor.
- ▶ Only use the mains/power cord supplied.



WARNING! Damage to health due to infectious liquids and pathogenic germs.

- ▶ When handling infectious liquids and pathogenic germs, observe the national regulations, the biosafety level of your laboratory, the material safety data sheets, and the manufacturer's application notes.
- ▶ Wear your personal protective equipment.
- ▶ For comprehensive regulations about handling germs or biological material of risk group II or higher, please refer to the "Laboratory Biosafety Manual" (source: World Health Organization, Laboratory Biosafety Manual, the current edition).



WARNING! Burns due to hot micro test tubes and device parts.

If the heater is at full power, the wall of the rotor chamber, the rotor and the micro test tubes will be heated to over 60 °C.

- ▶ Do not touch the wall of the rotor chamber.
- ▶ Use suitable protective clothing or auxiliary equipment to remove the micro test tubes.



NOTICE! Damage to rotors from aggressive chemicals.

Rotors are high-quality components which withstand extreme stresses. This stability can be impaired by aggressive chemicals.

- ▶ Avoid using aggressive chemicals, including strong and weak alkalis, strong acids, solutions with mercury, copper and other heavy metal ions, halogenated hydrocarbons, concentrated saline solutions and phenol.
- ▶ If the rotor is contaminated by aggressive chemicals, clean it immediately using a neutral cleaning agent. This applies in particular to the bottom panels of the rotors.



NOTICE! Damage to the device due to spilled liquids.

1. Switch off the device.
2. Disconnect the device from the mains/power supply.
3. Carefully clean the device and the accessories in accordance with the cleaning and disinfection instructions in the operating manual.
4. If a different cleaning and disinfecting method is to be used, contact Eppendorf AG to ensure that the intended method will not damage the device.



NOTICE! Damage to the device due to organic solvents

The use of organic solvents may affect some components, e.g. by discolorations.

- ▶ If this occurs, clean the device immediately using a mild cleaning agent.



NOTICE! Damage to electronic components due to condensation.

Condensate may form in the device when it has been transported from a cool environment to a warmer environment.

- ▶ After installing the device, wait for at least 3 h. Only then connect the device to the mains/power line.

2.5.2 Incorrect handling of the device



WARNING! Fingers may get crushed by the device lid.

- ▶ Do not reach between the device and lid when opening or closing the device lid.



NOTICE! Damage from knocking against or moving the device during operation.

If the rotor hits against the rotor chamber wall, this will cause considerable damage to the device and rotor.

- ▶ Do not move or knock against the device during operation.
-

2.5.3 Incorrect handling of the rotors

**WARNING! Risk of injury from improperly attached rotors.**

- ▶ Only operate the device if the rotor has been mounted properly.
 - ▶ If there are any unusual noises when the device is started up, stop the concentration immediately by pressing the **start/stop** key.
-

**CAUTION! Risk of injury due to asymmetric loading of a rotor.**

- ▶ Always load all positions of a swing-bucket rotor with buckets.
- ▶ Load buckets symmetrically with identical tubes or plates.
- ▶ Only load adapters with suitable tubes or plates.
- ▶ Always use tubes or plates of the same type (weight, material/density and volume).
- ▶ Ensure that tubes that are located opposite each other contain liquids with the same rate of evaporation. Otherwise an imbalance may occur and the concentration may be switched off automatically.
- ▶ Check that loading is symmetrical by balancing the adapters and tubes or plates used with a balance.

The device automatically detects imbalances during operation and stops the run immediately with an error message and a signal tone. Check the loading, balance the tubes and re-start the centrifugation.

**CAUTION! Risk of injury from overloaded rotor.**

The device is designed for the concentration of substances with a max. density of 1.2 g/mL at maximum speed and volume.

- ▶ Observe the maximum load for each rotor (adapter, tube and contents) per rotor bore or per bucket, and do not exceed this limit.
-

**WARNING! Risk of injury from chemically or mechanically damaged accessories.**

Even minor scratches and cracks can lead to severe internal material damage.

- ▶ Protect all accessory parts from mechanical damage.
 - ▶ Inspect the accessories for damage before each use. Replace any damaged accessories.
 - ▶ Do not use rotors or buckets that show signs of corrosion or mechanical damage (e.g., deformations).
 - ▶ Do not use accessories that have exceeded their maximum service life.
 - ▶ When inserting the buckets and rotors, ensure that they do not become scratched.
-

2.5.4 Extreme strain on the sample tubes



CAUTION! Risk of injury from overloaded tubes.

- ▶ Note the loading limits specified by the tube manufacturer.
- ▶ Only use tubes which are approved by the manufacturer for the required *g*-forces (rcf).



NOTICE! Risk from damaged tubes.

Damaged tubes must not be used as this could cause further damage to the device and the accessories and loss of the samples.

- ▶ Visually check all tubes for damage before use.



NOTICE! Damage to plastic tubes due to organic solvents.

When using organic solvents (e.g., phenol, chloroform), the strength of plastic tubes may be reduced and the tubes may become damaged.

- ▶ Observe the manufacturer's information on the chemical resistance of the tubes.



NOTICE! Micro test tubes are exposed to strong heat.

- ▶ Please note the temperature resistance of the micro test tubes.
-

2.5.5 Vacuum



WARNING! Risk of injury from direct contact with the vacuum.

- ▶ Do not expose any body parts to the vacuum of the device.



WARNING! Risk of injury due to positive pressure.

Positive pressure in the exhaust gas lines (e.g., due to closed taps or blocked lines) may cause the lines to burst.

- ▶ Only use lines with a sufficiently large cross section.
- ▶ Keep the exhaust gas line free at all times.
- ▶ Do not place any objects on the exhaust gas lines.
- ▶ Do not bend the exhaust gas lines.
- ▶ Do not fit any hose clamps or valves to the exhaust gas lines.
- ▶ Note the maximum pressures and differential pressures permitted (see p. 57).

Safety

Concentrator plus/Vacufuge® plus
English (EN)

**WARNING! Damage to health due to escaping substances.**

No vapors from toxic liquids and pathogenic germs must escape.

- ▶ Ensure the required condensation and separation of vapors using suitable cold traps or chemical traps.
- ▶ Wear personal protective equipment (gloves, clothing, goggles, etc.), ensure proper ventilation and note the biosafety level of the lab.

2.6 Safety instructions on the device

Depiction	Meaning	Location
	Notice, observe the operating manual	Complete system: On the right side of the device next to the mains/power connection. Basic device: On the rear of the device next to the mains/power switch.
	Risk of explosion <ul style="list-style-type: none"> ▶ Do not use this device to process any explosive, radioactive or highly reactive substances. ▶ Do not use this device to process any substances which could create an explosive atmosphere. 	On the top of the device.
	Risk of scalding when the device lid is open When the heater is switched on, the surface temperature of the rotor chamber can be >60 °C. <ul style="list-style-type: none"> ▶ Do not touch the wall of the rotor chamber. 	On the top of the device.
	Risk of injury from overpressure The connection on the top of the emission condenser is intended as an outlet only. <ul style="list-style-type: none"> ▶ Make sure that the emission condenser is connected correctly. ▶ Never shut this connection off. 	On the top of the emission condenser.

3 Product description

3.1 Product overview

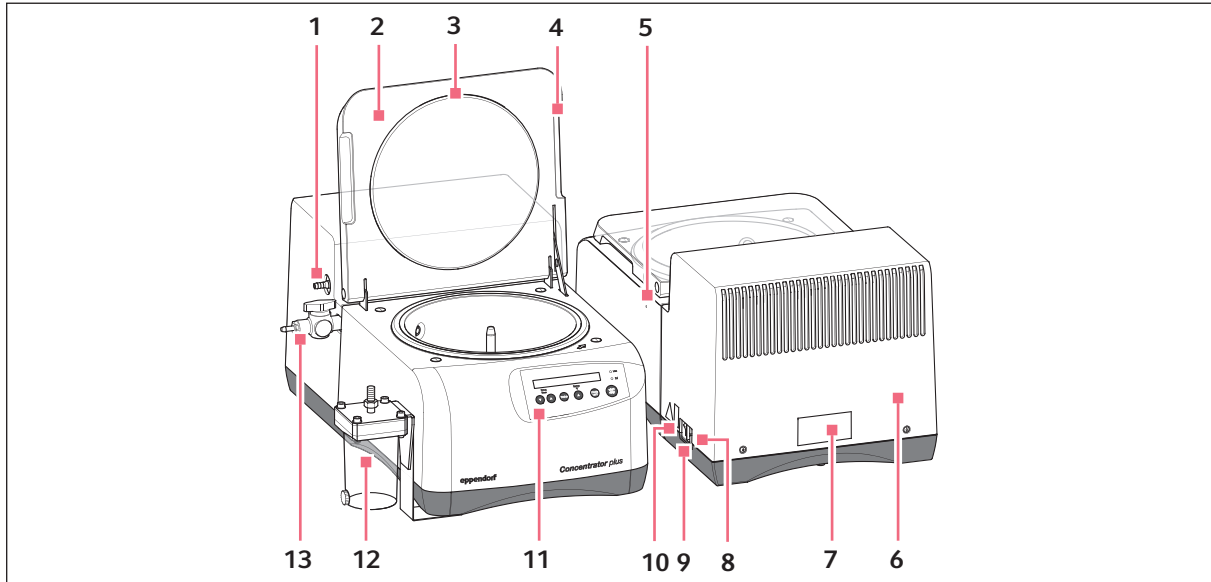

Fig. 3-1: Complete system with gel dryer connection

- | | |
|---|--|
| 1 Pump outlet of the integrated diaphragm vacuum pump (complete system) | 8 Mains/power connection |
| 2 Lid made from PMMA | 9 Fuse holder |
| 3 Sealing ring | 10 Mains/power switch |
| 4 Grip recess | 11 Operating controls and device display |
| 5 Emergency release | 12 Emission condenser |
| 6 Pump housing (complete system) | 13 Pump hose connection on basic device for external vacuum pump |
| 7 Name plate | |

Product description

Concentrator plus/Vacufuge® plus
English (EN)

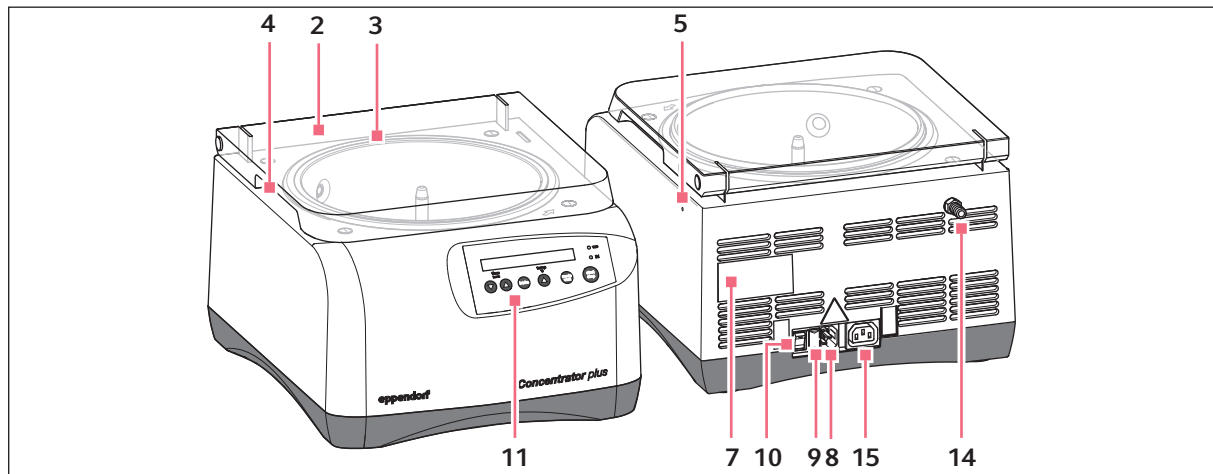

Fig. 3-2: Basic device

2 Lid made from PMMA

3 Sealing ring

4 Grip recess

5 Emergency release

7 Name plate

8 Mains/power connection

9 Fuse holder

10 Mains/power switch

11 Operating controls and device display

14 Mains/power connection for external vacuum pump

15 Earth/grounded socket for mains/power plug

3.2 Delivery package

Tab. 3-1: Complete system

1	Concentrator plus/Vacufuge plus
1	Mains/power cord
1	Emission condenser
1	Hose for emission condenser
1	Hose connection
1	Angle connection
1	Set of fuses
1	Instructions

Tab. 3-2: Basic device

1	Concentrator plus/Vacufuge plus
1	Mains/power cord
1	Set of fuses
1	Instructions



- ▶ Check whether the delivery is complete.
- ▶ Check all parts for any transport damage.
- ▶ To safely transport and store the device, retain the transport box and packing material.

3.3 Features

The Concentrator plus is designed for the evaporation of liquid or wet samples in micro test tubes, round-bottom tubes, conical tubes, flat-bottom tubes and different plates.

You can insert the following tubes and plates:

- 1.5 and 2.0 mL micro test tubes in a rotor with 70 positions.
- 0.5 mL micro test tubes in a rotor with 72 positions.
- 5 mL micro test tubes in a rotor with 22 positions.
- 15 mL conical tubes in a rotor with 8 positions.
- 50 mL conical tubes in a rotor with 6 positions.
- MTP and PCR plates in a swing-bucket rotor.

Product description

Concentrator plus/Vacufuge® plus
English (EN)

A complete list can be found in the following chapter (see *Rotors on p. 58*).

The device is available as a complete system with an integrated diaphragm vacuum pump or as a basic device without a vacuum pump. The basic device can be connected to an external vacuum system.

The Concentrator plus has the following functions:

- 3 temperature levels can be set (30, 45, 60 °C). Alternatively, evacuation is carried out without temperature control.
- The evaporation of liquids can be carried out optimized in 3 functions. In addition to pure evacuation, aqueous and/or alcoholic solutions can be concentrated extra fast with 2 special functions.
- You can also operate the device as a pure desiccator.
- You can connect a solvent trap to the device behind the pump.

3.4 Name plate

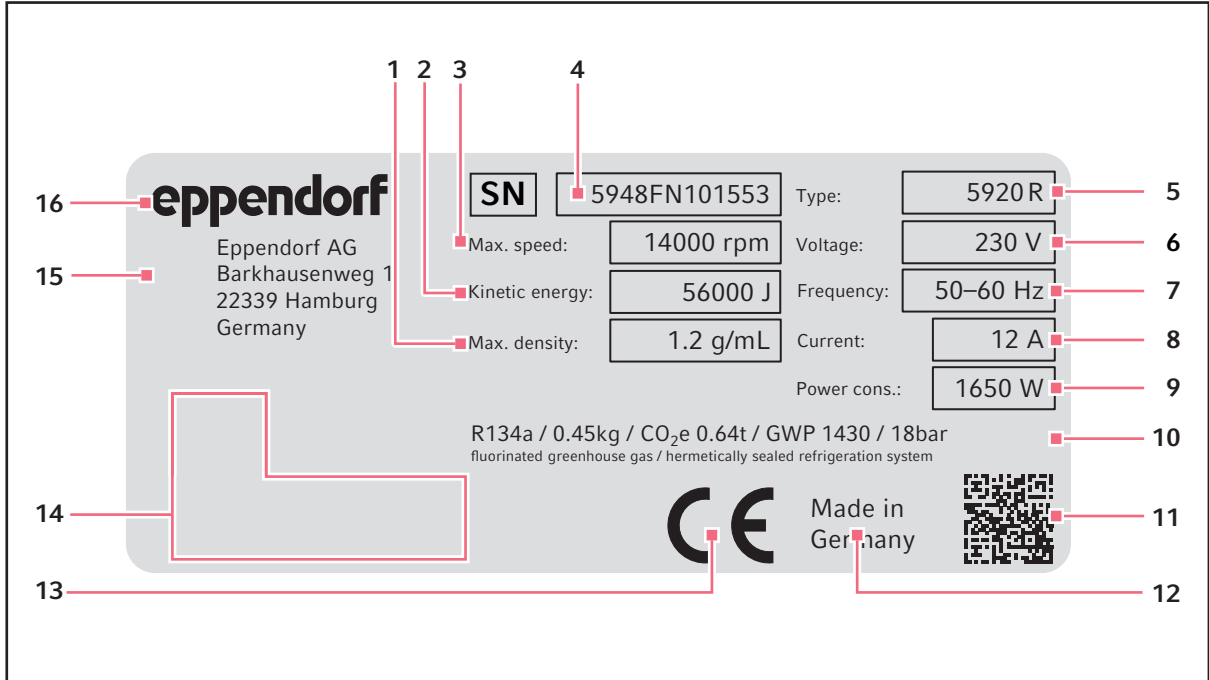







Fig. 3-3: Eppendorf AG device identification (example)

- | | |
|---|--|
| <ul style="list-style-type: none"> 1 Maximum density of the material for centrifuging 2 Maximum kinetic energy 3 Maximum speed 4 Serial number 5 Product name 6 Rated voltage 7 Rated frequency 8 Maximum rated current | <ul style="list-style-type: none"> 9 Maximum rated power 10 Information on the refrigerant (refrigerated centrifuges only) 11 Data matrix code for serial number 12 Designation of origin 13 CE marking 14 Certification marks and symbols (device-specific) 15 Manufacturer's address 16 Manufacturer |
|---|--|

Product description

Concentrator plus/Vacufuge® plus
English (EN)

Tab. 3-3: Certification and conformity marks and symbols (device-specific)

Symbol/sign	Meaning
	Serial number
	Marking of electrical and electronic equipment in conformity with standard EN 50419 in accordance with directive 2012/19/EU (WEEE) of the European Union
	UL listing certification mark: Representative samples of the device have been tested by Underwriters Laboratories (UL) in accordance with the applicable safety standards for the USA and Canada
	FCC mark of conformity; the instrument's electromagnetic compatibility has been tested in accordance with <i>Federal Communications Commission</i> (FCC, USA) regulations
	RoHS mark in accordance with standard SJ/T 11364, <i>Marking for the restriction of the use of hazardous substances in electrical and electronic products</i> , People's Republic of China
	Conformity with the relevant directives for the Eurasian Economic Union

4 Installation

4.1 Selecting the location



WARNING! Danger due to incorrect voltage supply.

- ▶ Only connect the device to voltage sources which correspond with the electrical requirements on the name plate.
 - ▶ Only use earth/grounded sockets with a protective earth (PE) conductor.
 - ▶ Only use the mains/power cord supplied.
-



NOTICE! If an error occurs, objects in the immediate vicinity of the device may become damaged.

- ▶ In accordance with the recommendations of EN 61010-2-020, leave a safety clearance of **30 cm** around the device during operation.
 - ▶ Please remove all materials and objects from this area.
-



NOTICE! Damage due to overheating.

- ▶ Do not position the device near heat sources (e.g., heating, drying cabinets).
 - ▶ Do not expose the device to direct sunlight.
 - ▶ Ensure unobstructed air circulation. On all sides of the device, ensure that there is a minimum gap of 30 cm not obstructed to adjacent devices or to the wall. Ensure that the bottom of the device is not obstructed.
 - ▶ Always keep the ventilation gaps of the device free from obstructions.
-



NOTICE! Radio interference.

For devices with Class A noise emission in accordance with EN 61326-1/EN 55011, the following applies: This device has been developed and tested in accordance with CISPR 11 Class A. The device may cause radio interference in domestic environments and is not intended for use in residential areas. The device cannot ensure adequate protection of radio reception in residential areas and domestic environments.

- ▶ If necessary, take appropriate measure to eliminate the interferences.
-



The mains/power switch and the disconnecting device of the mains/power line must be easily accessible during operation (e.g. a residual current circuit breaker).



Mains/power connection for the concentrator: Operation of the concentrator is only permitted in building installations that comply with the applicable national regulations and standards. In particular, it must be ensured that there are no impermissible loads on the supply lines and assemblies that are located upstream of the internal protection of the device. This can be ensured by additional circuit breakers or other suitable safety elements in the building installation.

Installation

Concentrator plus/Vacufuge® plus
English (EN)



The mains/power switch and the disconnecting device of the mains/power line must be easily accessible during operation (e.g., residual current circuit breaker).

Select the location for the device according to the following criteria:

- Suitable mains/power connection in accordance with the name plate
- Minimum distance to other devices and walls: 30 cm
- Resonance free table with horizontal even work surface
- The location must be well ventilated
- The location is protected against direct sunlight
- Ambient temperature during operation: 15 to 35 °C
- At altitudes above 1000 m MSL, measures to ensure the supply of cooling air in accordance with DIN EN 60034-1; VDE 0530-1 are required

4.2 Preparing installation



WARNING! Risk of injury from operating an incorrectly installed device.

The device is not ready for operation after it has been installed. Additional components are missing.

- ▶ Read the following chapter before operating the device (see *General installation on p. 24*).



The weight of the complete system is 31.5 kg. The weight of the basic device is 16.5 kg.

- Two persons are always required to transport and install the device.
- Only transport the device in its original packing.
- Use a transport aid for longer distances (e.g., hand truck).
- Keep the packaging board and the transport securing device for later transport or storage. See also the instructions relating to transport (see p. 53).

Please complete the following steps in the order described:

1. Open the packaging board.
2. Remove the accessories and rotors.
3. Cut the strap retainers.
4. Lift the device with the transport protection pad out of the box and place it on a stable, level and non-resonant lab bench.
5. Carefully place the device with the transport protection pad on its side.

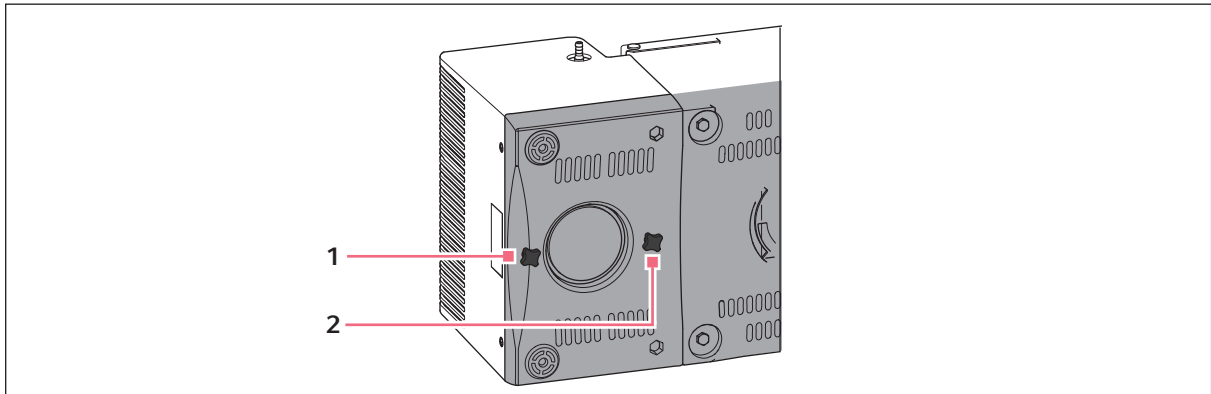

Fig. 4-1: Transport protection screws on the bottom of the device (complete system)

1 Rear transport protection screw

2 Front transport protection screw

6. Slide the rear transport protection pad on the bottom of the device slightly back until the rear transport protection screw is visible.
7. Unscrew and remove both transport protection screws.
8. Slide the rear transport protection pad to its original position.
9. Return the device with the transport protection pad to the upright position.
10. Slide the rear transport protection pad on the bottom of the device slightly back until the rear transport protection screw is visible.
11. Remove the front and rear transport protection pads.
12. Remove the plastic covers from the device and the lid.
13. Install the device in a well-ventilated location which is protected from direct sunlight to prevent it from overheating.

Installation

Concentrator plus/Vacufuge® plus
English (EN)

4.3 Installing the instrument

4.3.1 General installation

**WARNING! Danger due to incorrect voltage supply.**

- ▶ Only connect the device to voltage sources which correspond with the electrical requirements on the name plate.
- ▶ Only use earth/grounded sockets with a protective earth (PE) conductor.
- ▶ Only use the mains/power cord supplied.

**WARNING! Damage to health due to escaping substances.**

No vapors from toxic liquids and pathogenic germs must escape.

- ▶ Ensure the required condensation and separation of vapors using suitable cold traps or chemical traps.
- ▶ Wear personal protective equipment (gloves, clothing, goggles, etc.), ensure proper ventilation and note the biosafety level of the lab.

**NOTICE! Damage to electronic components due to condensation.**

Condensate may form in the device when it has been transported from a cool environment to a warmer environment.

- ▶ After installing the device, wait for at least 3 h. Only then connect the device to the mains/power line.



Select a setup for the collection and/or discharge of liquids and gases which complies with the applicable legal requirements and regulations for your application.

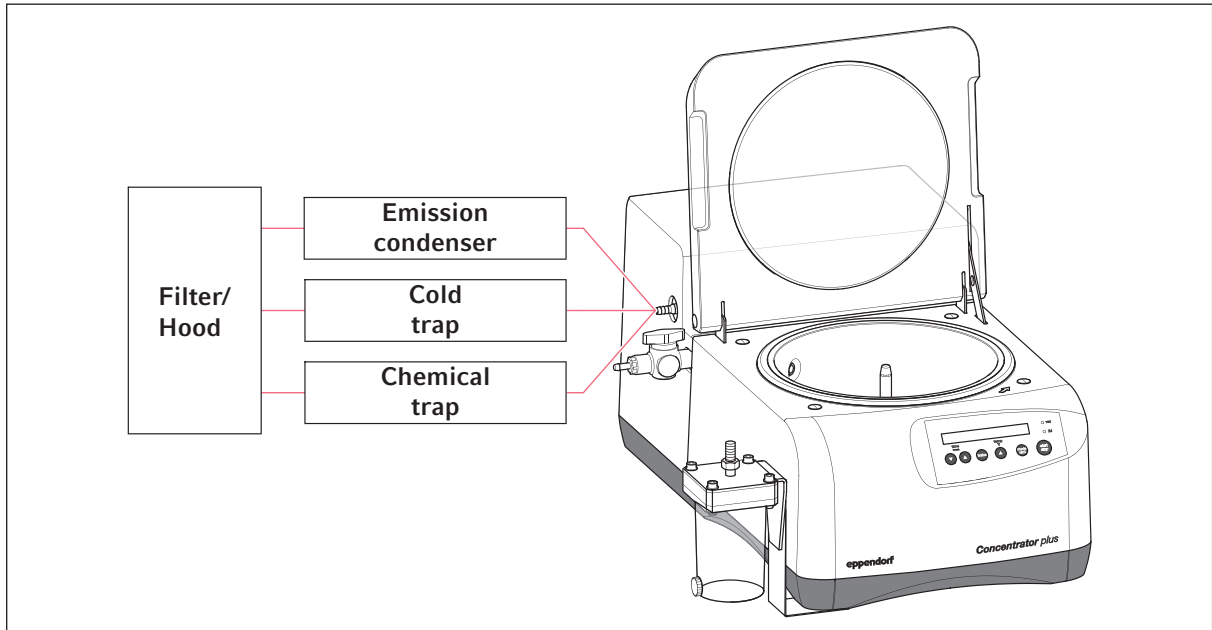

Fig. 4-2: Connection options for the complete system

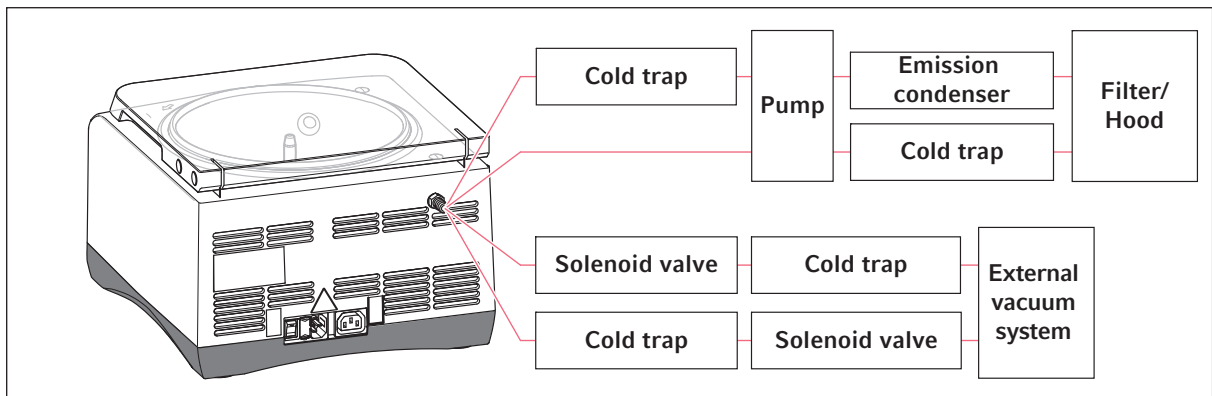

Fig. 4-3: Connection options for the basic device

Installation

Concentrator plus/Vacufuge® plus
English (EN)

Perform the following steps in the order described:

1. Connect the components according to your chosen configuration. Please note the relevant instructions in the following chapters.
 - Complete system: Connecting the emission condenser (see p. 26).
 - Complete system: Connecting the gel dryer (see p. 27).
 - Basic device: Connecting the vacuum pump (see p. 28).
2. Check that the mains/power supply voltage and frequency match the requirements on the device name plate.
3. Connect the device to the mains/power line and switch it on with the mains/power switch located on the right of the device (basic device: on the rear of the device) (refer to front fold-out page).
 - The display is active.
 - The lid is unlocked (**the lid** indicator lamp lights up).
 - You can now open the lid.

4.3.2 Complete system: Connecting the emission condenser



WARNING! Risk of injury due to positive pressure.

Positive pressure in the exhaust gas lines (e.g., due to closed taps or blocked lines) may cause the lines to burst.

- ▶ Only use lines with a sufficiently large cross section.
- ▶ Keep the exhaust gas line free at all times.
- ▶ Do not place any objects on the exhaust gas lines.
- ▶ Do not bend the exhaust gas lines.
- ▶ Do not fit any hose clamps or valves to the exhaust gas lines.
- ▶ Note the maximum pressures and differential pressures permitted (see p. 57).



Check whether using the emission condenser is sufficient for the intended application. For the concentration of chemically aggressive or biologically hazardous substances one of the following measures must be taken:

- Replace the emission condenser with a suitable cold trap or chemical trap.
- In addition, place the emission condenser in an ice bath.
- Attach a hose to the upper connection of the emission condenser and connect it to an extraction system.
- Set up a series connection of cold trap or chemical trap and emission condenser.



The pump of the Concentrator plus is fully solvent resistant. Therefore, the emission condenser can be placed behind the pump.

1. Unpack the emission condenser.
2. Remove the red cap from the upper connection.
3. Screw the angle connection to the side of the emission condenser.



The emission condenser inlet needs to be lower than the pump outlet to prevent liquid from collecting in the hose.

4. Attach the hose to the pump outlet and the connection on the side of the emission condenser.
5. Attach the emission condenser from the side or from the front under the front left foot of the device.

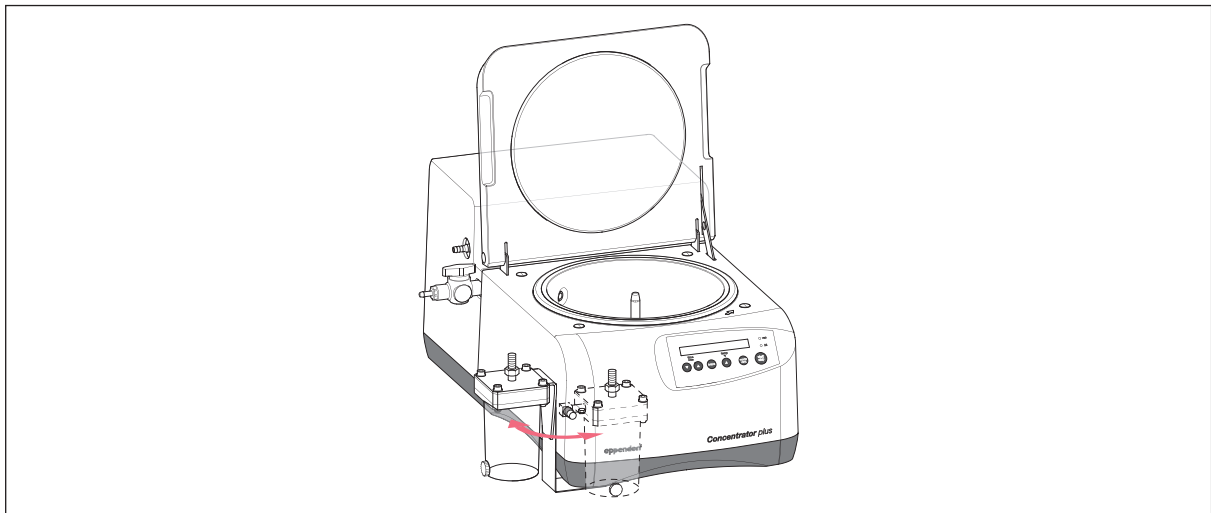

6. You can install a filter at the upper connection of the emission condenser. The overpressure at the pump outlet of the complete system must not exceed 1 bar.

4.3.3 Complete system: Connecting the gel dryer

Prerequisites

- 1 connecting hose (length: max. 50 cm, inner diameter: 5 to 7 mm, chemical resistant and suitable for vacuum applications).

1. Screw the supplied hose connection (size: G1/4 ") into the thread of the stop valve on the left of the device.
2. Connect the gel dryer to the hose connection with the connecting hose.

4.3.4 Basic device: Connecting the vacuum pump



WARNING! Danger of explosion from gas mixtures.

When running several devices in parallel on a vacuum system or in combination with a gel dryer, an explosive gas mixture may develop in the vacuum system.

- ▶ Observe the solvent properties. Only carry out parallel operations with identical solvents or solvents that evaporate in a non-hazardous manner.

The basic device can be connected to an external vacuum pump.

Prerequisites

- The vacuum pump is approved in accordance with the applicable standards in your country.
- A condenser (e.g., emission condenser, cold trap or chemical trap) between the devices or behind the vacuum pump, depending on your application.
- The pump withstands an ultimate pressure of at least 20 mbar. Its suction capacity is at least 1.8 m³/h.



Vacuum pumps which meet these requirements can for example be diaphragm or rotary vane pumps. The specifications can be found in the vacuum pump's technical data or requested from the manufacturer. If you have any other questions regarding the correct operation of the vacuum pump, e.g., handling, use, performance, service, troubleshooting or the specification and connecting a cold trap, please also contact the manufacturer.



Should you encounter any problems when connecting the vacuum pump, please contact Technical Service. The contact addresses can be found at the end of the operating manual or on the Internet at www.eppendorf.com.

4.3.4.1 Connecting a vacuum pump up to 350 W

Prerequisites

- Power consumption of the vacuum pump: max. 350 W or connected electrical connection load max. 400 VA.
- Special plug for control and mains/power supply of the vacuum pump (see *Accessories on p. 63*).
- 1 connecting hose (length: max. 50 cm, inner diameter: 8 mm, chemical resistant and suitable for vacuum applications).

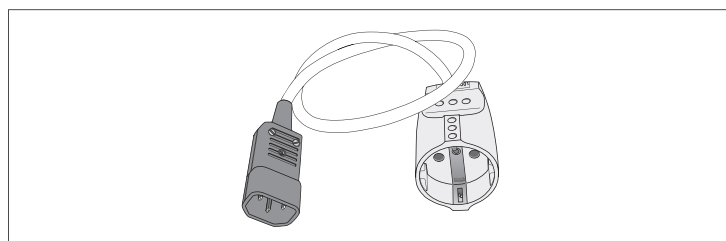

Fig. 4-4: Special plug for control and mains/power supply of a vacuum pump **with a power consumption of up to 350 W.**

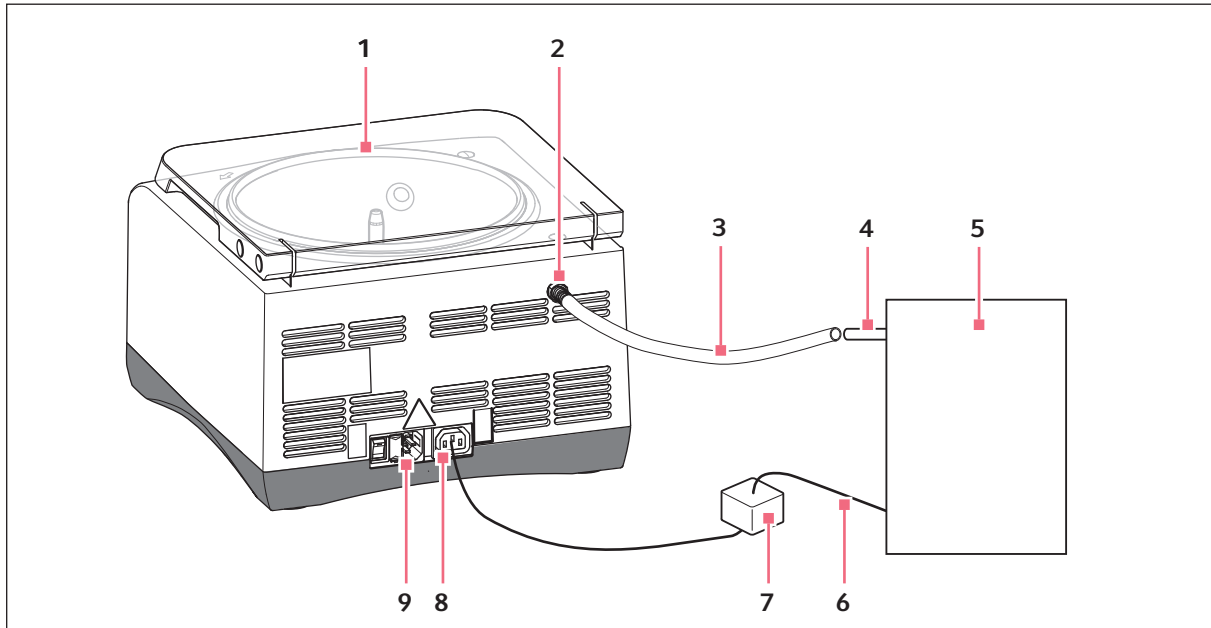

Fig. 4-5: Connecting a vacuum pump **with a power consumption of up to 350 W** to the Concentrator plus basic device.

- | | |
|---------------------|---------------------------------------|
| 1 Basic device | 6 Mains/power cord of the vacuum pump |
| 2 Pump connection | 7 Special plug |
| 3 Connecting hose | 8 Plug socket |
| 4 Vacuum pump inlet | 9 Mains/power line socket |
| 5 Vacuum pump | |

1. Disconnect the device and the vacuum pump from the mains/power line.
2. Plug the mains/power cord of the vacuum pump into the special plug.
3. Connect the special plug to the provided plug socket on the rear of the device (connected mains/power supply voltage!).
4. Install the connecting hose between the vacuum pump inlet and the pump connection on the rear of the device.
5. Connect the device to the mains/power line.

Installation

Concentrator plus/Vacufuge® plus
English (EN)

4.3.4.2 Connecting a vacuum pump with external mains/power supply

Prerequisites

- Additional power source for the vacuum pump.
- Solenoid valve to control the vacuum pump with the basic device (see *Accessories on p. 63*).
- 2 connecting hoses (length: max. 50 cm, inner diameter: 8 mm, chemical resistant and suitable for vacuum applications)

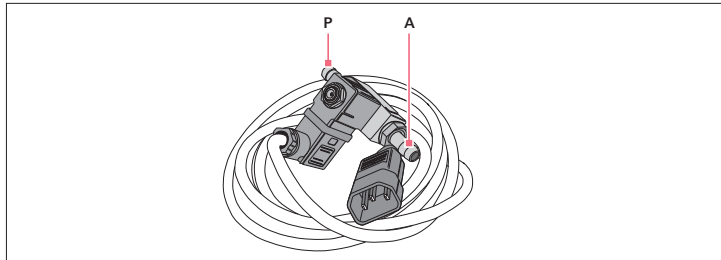

Fig. 4-6: Solenoid valve to control a vacuum pump with external mains/power supply.

A Hose connection to vacuum pump

P Hose connection to device

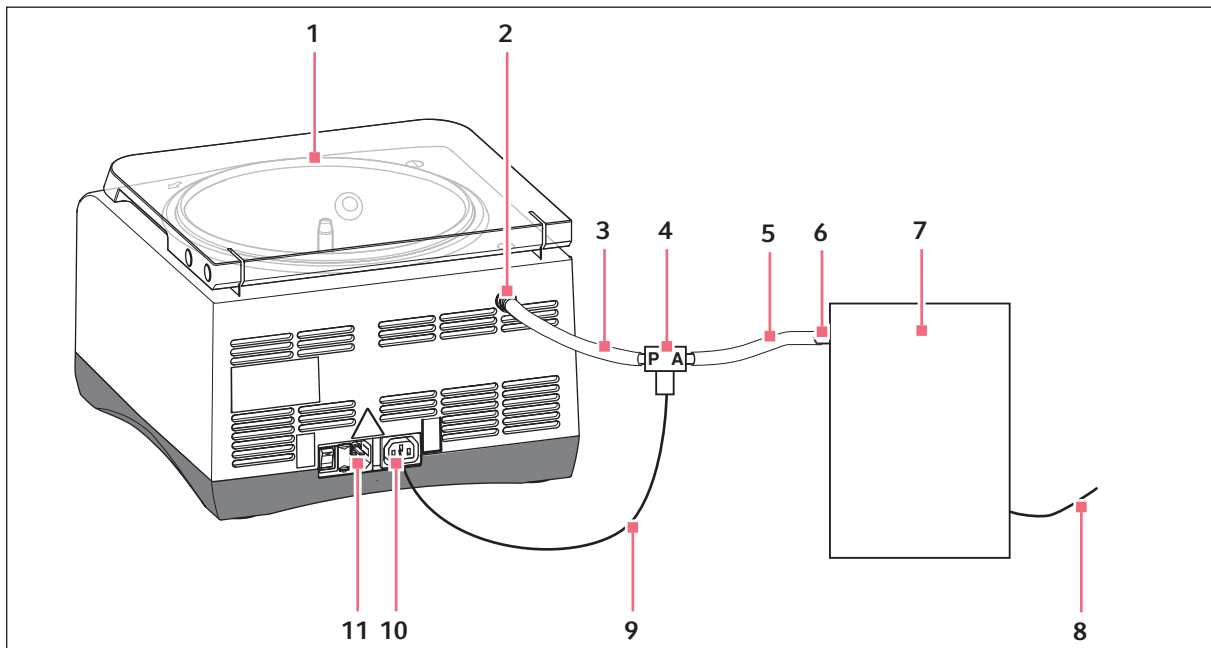

Fig. 4-7: Connecting a vacuum pump with external mains/power supply to the Concentrator plus basic device.

- | | |
|---------------------------------|---|
| 1 Basic device | 7 Vacuum pump |
| 2 Pump connection on the device | 8 Mains/power line cable |
| 3 Connecting hose | 9 Mains/power plug |
| 4 Solenoid valve | 10 Connection socket for the solenoid valve |
| 5 Connecting hose | 11 Mains/power line connection socket |
| 6 Vacuum pump inlet | |

1. Disconnect the basic device and the vacuum pump from the mains/power line.
2. Connect **hose connection P** of the solenoid valve to a connecting hose and attach the other end of the connecting hose to the pump connection on the rear of the device.
3. Connect **hose connection A** of the solenoid valve to a connecting hose and attach the other end of the connecting hose to the vacuum pump inlet.
4. Connect the plug of the solenoid valve to the provided connection socket on the rear of the device (connected mains/power supply voltage!).
5. Connect the device to the mains/power line.
6. Connect the vacuum pump to the mains/power line.



The vacuum pump is isolated from the device automatically before concentration is complete by the closure of the solenoid valve which is piloted by the concentrator. The vacuum pump can also be isolated from the device without a solenoid valve by manually closing an in-line valve (e.g., stop valve with ground-in stopper).

Installation

Concentrator plus/Vacufuge® plus
English (EN)

5 Operation

5.1 Operating controls

Before using the device for the first time, familiarize yourself with the operating controls and the device display.

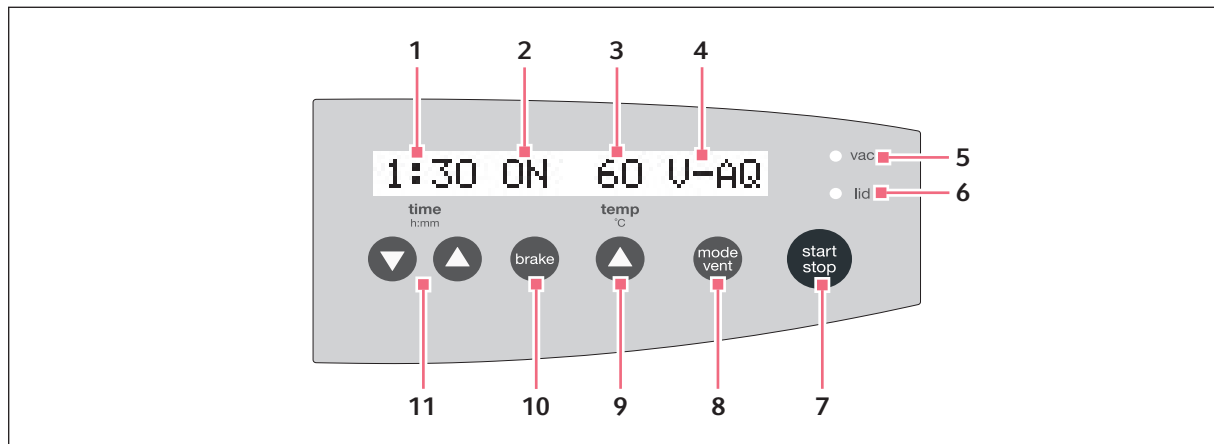

1 Concentration run time

1 min to 9:59 h, unlimited (oo), adjustable in 1 min. increments.

2 Braking function

ON: Braking function on. *OFF*: Braking function off.

3 Temperature

--: Heating off. 30/45/60 °C: Heating on.

4 Mode

5 Status of the diaphragm vacuum pump (vac)

Off: Pump off. On: Pump running.

6 Status of the device lid (lid)

Off: Lid locked. On: Lid unlocked.

7 Start or stop concentration

8 Set the mode

Manual ventilation of the rotor chamber during a concentrator/desiccator run while the key is pressed. *Ventilation* is displayed.

9 Set the temperature

10 Set the braking function

11 Set the concentration run time

Operation

Concentrator plus/Vacufuge® plus
English (EN)

5.2 Possible applications

The device can be used as a concentrator, a desiccator, or a centrifuge. For the concentrator and desiccator functions, there are three different modes available for the quick concentration of different solvents:

Function	Mode	Suitable for
Concentrator	<i>V-AQ</i> (vacuum - aqueous)	Aqueous solutions
	<i>V-AL</i> (vacuum - alcoholic)	Alcoholic solutions
	<i>V-HV</i> (vacuum - high vapor)	Solutions with high vapor pressure
Desiccator	<i>D-AQ</i> (desiccator - aqueous)	Aqueous solutions
	<i>D-AL</i> (desiccator - alcoholic)	Alcoholic solutions
	<i>D-HV</i> (desiccator - high vapor)	Solutions with high vapor pressure and dry substances
Centrifuge	<i>CEFU</i> (centrifuge)	Centrifugation at 1,400 min ⁻¹

► To set the desired function, press the **mode/vent** key before operation of the device.



Use the *V-AQ*, *V-AL*, *D-AQ* or *D-AL* modes if possible, or press the **mode/vent** key from time to time during the run.



During operation, you cannot change the set function. Instead, holding the **mode/vent** key during the concentrator or desiccator function ventilates the rotor chamber.

5.3 Preparation for concentration**5.3.1 Switching on the device**

Please note before putting the device into operation that the ambient temperature during operation must be between 15 and 35 °C.

At altitudes above 1000 m MSL, measures to ensure the supply of cooling air in accordance with DIN EN 60034-1; VDE 0530-1 are required.

► Switch on the device at the mains/power switch.

- The display is active.
- The lid is released (**the lid** indicator lamp lights up).
- You can now open the lid.
- The parameter settings of the last run are displayed.

5.3.2 Inserting the rotor



First observe the rotor information and the special notes on rotors F-35-6-30, F-45-72-8, F-45-48-11, F-45-24-12 and A-2-VC (see p. 61).

Rotor A-2-VC: remove the buckets before inserting the rotor and pick it up at the rotor cross using both hands.

Proceed as follows when inserting the rotor:

1. Place the rotor on the motor shaft.
2. Push the rotor down using slight pressure until you encounter resistance.



The rotors do not need to be screwed in.

5.3.3 Starting the warm-up phase

The diaphragm vacuum pump reaches the displayed output and the ultimate pressure (see p. 57) only after the device has gone through a 15-minute warm-up phase. The warm-up phase reduces the condensation of liquid in the pump and on the lid of the rotor chamber and therefore prolongs the service life of the pump.



WARNING! Fingers may get crushed by the device lid.

- ▶ Do not reach between the device and lid when opening or closing the device lid.

1. **time** arrow keys: set the time to 15 minutes.
2. **brake**: switch the brake on or off.
3. **temp**: select the temperature.
4. **mode/vent**: select the *V-AQ*, *V-AL* or *V-HV* mode.
5. Close the lid of the device.
6. **Press start/stop** to start the warm-up phase.
 - The device lid is locked, and the blue **lid** indicator lamp goes out.
 - The rotor starts up.
 - At 1,000 rpm, the vacuum pump switches on, and the **vac** indicator lamp lights up.
 - The vent valve is closed.
 - The rotor accelerates to the end point of 1,400 rpm.
 - On the display, the colon in the time display flashes while the rotor is turning.
 - The remaining run time is displayed in hours and minutes.

Operation

Concentrator plus/Vacufuge® plus
English (EN)

After the warm-up phase is completed

- The device stops automatically.
- During braking, the elapsed concentration time flashes on the display.
- The rotor chamber is ventilated so that the pressure in the chamber increases slowly.
- After two seconds, the vacuum pump switches off, and **the vac** indicator lamp goes out.
- Then the device brakes.
- When the rotor has come to a standstill, the **lid** indicator lamp lights up.
- The lid can be opened.

5.3.4 Loading a fixed-angle rotor

The following notes apply to fixed-angle rotors. Loading the rotor A-2-VC is described in the following chapter (see *Loading a swing-bucket rotor on p. 37*).



CAUTION! Risk of injury due to asymmetric loading of a rotor.

- ▶ Always load all positions of a swing-bucket rotor with buckets.
- ▶ Load buckets symmetrically with identical tubes or plates.
- ▶ Only load adapters with suitable tubes or plates.
- ▶ Always use tubes or plates of the same type (weight, material/density and volume).
- ▶ Ensure that tubes that are located opposite each other contain liquids with the same rate of evaporation. Otherwise an imbalance may occur and the concentration may be switched off automatically.
- ▶ Check that loading is symmetrical by balancing the adapters and tubes or plates used with a balance.

The device automatically detects imbalances during operation and stops the run immediately with an error message and a signal tone. Check the loading, balance the tubes and re-start the centrifugation.



CAUTION! Risk from damaged or overloaded tubes.

- ▶ When loading the rotor, observe the safety instructions for hazards resulting from overloaded or damaged tubes.

Proceed as follows when loading the fixed-angle rotor:

1. Check the maximum payload (tube and content) per rotor bore. Detailed information can be found in this operating manual (see *Rotors on p. 58*).
2. Only load rotors with the tubes intended for this purpose.
3. Insert open tubes opposite each other in pairs into the rotor bores. To ensure symmetrical loading, tubes that are arranged opposite each other must be of the same type and contain the same filling quantity.

In order to minimize weight differences between the filled micro test tubes, we recommend taring with a balance. This will reduce wear on the drive and cut operating noise.

5.3.5 Loading a swing-bucket rotor

Prerequisites

- A rotor, bucket and adapter combination approved by Eppendorf.
- **Two** inserted buckets.
- Matching and tested tubes and plates.
- Adapters and plates with a total height of ≤ 27 mm.



CAUTION! Risk of injury due to asymmetric loading of a rotor.

- ▶ Always load all positions of a swing-bucket rotor with buckets.
- ▶ Load buckets symmetrically with identical tubes or plates.
- ▶ Only load adapters with suitable tubes or plates.
- ▶ Always use tubes or plates of the same type (weight, material/density and volume).
- ▶ Ensure that tubes that are located opposite each other contain liquids with the same rate of evaporation. Otherwise an imbalance may occur and the concentration may be switched off automatically.
- ▶ Check that loading is symmetrical by balancing the adapters and tubes or plates used with a balance.

The device automatically detects imbalances during operation and stops the run immediately with an error message and a signal tone. Check the loading, balance the tubes and re-start the centrifugation.



NOTICE! Filling the plates too high can cause overflowing.

During the run the menisci in the tubes along the edges of the plates are at an angle. This is due to the centrifugal forces and cannot be avoided.

- ▶ Fill the plate wells to a maximum of 2/3 of the maximum filling volume.

1. Check the bucket grooves for cleanliness and grease them lightly with pivot grease (order no. int.: 5810 350.050/North America: 022634330).

Dirty grooves and pivots prevent the buckets from swinging out evenly.

2. Hang the buckets into the rotor.
3. Check that both buckets are hanging properly and can swing out freely.
4. When using a plate type for the first time, carry out a manual loading and swing-out test.
5. Check the maximum payload (adapter, plate and content) per bucket.

The relevant details can be found on the rotor and in this operating manual (see *Rotors on p. 58*).

6. Load the buckets symmetrically when inserting adapters and plates.

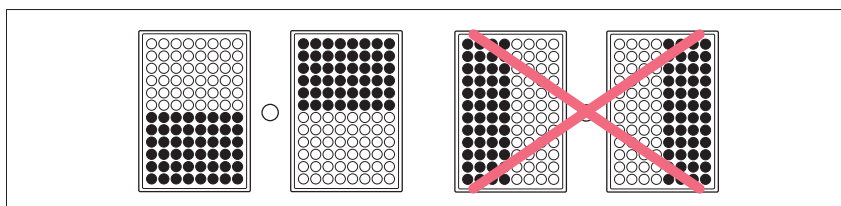

Operation

Concentrator plus/Vacufuge® plus
English (EN)

The plate arrangement shown on the right-hand side is incorrect as the buckets will not swing out properly.

The plates have some play in the buckets.

5.3.6 Closing the lid of the device



WARNING! Fingers may get crushed by the device lid.

- ▶ Do not reach between the device and lid when opening or closing the device lid.

1. Check that the rotor is correctly positioned.
2. Close the lid of the device.

5.4 Starting the concentration process

Each of the applications described here must be preceded by the preparation described above (see *Preparation for concentration on p. 34*).



WARNING! Risk of injury from improperly attached rotors.

- ▶ Only operate the device if the rotor has been mounted properly.
- ▶ If there are any unusual noises when the device is started up, stop the concentration immediately by pressing the **start/stop** key.



CAUTION! Danger due to incorrectly loaded rotors and damaged/overloaded tubes!

- ▶ Before commencing concentration, follow the safety instructions relating to risks from asymmetrically loaded and/or overloaded rotors and from overloaded and/or damaged tubes.



NOTICE! Overflowing of the emission condenser.

The maximum filling volume of the emission condenser is 280 mL.

1. Check before each run whether the volume of the emission condenser is sufficient for your application.
2. Empty the emission condenser if necessary.



Unusual noises may occur when braking heavy rotors. This is construction-related and does not indicate a problem.



If a temperature has been set, the rotor chamber is heated continuously, i.e., even when the rotor has stopped and the lid is open. Therefore, switch the device off after completing the application or set the temperature to -- (no temperature set), if applicable.

5.4.1 Starting the concentration process with time setting

Perform the following steps in the order described:

1. **time** arrow keys: set the run time.
2. **brake**: switch the brake on or off.
3. **temp**: select the temperature (note the temperature resistance of the samples).
4. **mode/vent**: select *the V-AQ, V-AL or V-HV* mode.
5. **start/stop**: start the concentration process.
 - The device lid is locked, the blue **lid** indicator lamp goes out.
 - The rotor starts accelerating.
 - At 1,000 rpm, the vacuum pump starts, and the **vac** indicator lamp lights up.
 - The vent valve closes.
 - The rotor accelerates to the end point of 1,400 rpm.
 - On the display, the colon in the time display flashes while the rotor is turning.
 - The remaining run time is displayed in hours and minutes.



During a concentration process you can:

- Change the total run time. The new parameters are adopted immediately. Please note that the shortest new total run time that can be set is the elapsed time plus 2 minutes.
- Adjust the braking function.
- Adjust the temperature.
- Manually ventilate the rotor chamber by keeping the **mode/vent** key pressed. This will remove condensation from the device lid and flush the pump and the hose system.

5.4.2 Starting the concentration process with continuous run



CAUTION! Continuous operation may affect the safe operation of the device.

If operated continuously to deliver liquids, the membranes and valves of the vacuum pump may become damaged.

- ▶ Only use the device for applications of limited duration.

Use the continuous run function if you do not want to set a fixed run time .

1. Use the **time** arrow keys to set the continuous run function (oo), *this can be achieved below 0:01 or above 9:59*.
2. Set all other parameters as described above (see *Starting the concentration process with time setting on p. 39*).
3. **Press start/stop** to start the concentration process.
The time is counted up in increments of 1 minute.
4. **Press start/stop** to end the concentration process after the desired time period.



If the device runs for more than 9:59 h, 9:59 remains on the display.

Operation

Concentrator plus/Vacufuge® plus
English (EN)

5.4.3 Completing the concentration process

After completion of the concentration process:

- The device stops automatically (time setting) or manually (continuous run).
 - The elapsed concentration time flashes on the display during the braking process.
 - The rotor chamber is ventilated so that the pressure in the chamber increases slowly.
 - After two seconds, the vacuum pump switches off, and **the vac** indicator lamp goes out.
 - The device then decelerates.
 - After the rotor has stopped, the **lid** indicator lamp lights up.
 - The lid can be opened and the samples removed.
1. Open the lid and remove the samples.
 2. Close the lid.
 3. Let the device continue to run in *D-AQ* mode with an empty rotor for 15 minutes after completing the application.

5.4.4 Removing the rotor



Rotor A-2-VC: First remove the buckets, then grip the rotor at the rotor cross with both hands to lift it out of the device.

1. Switch the heating off if applicable.
2. Remove the rotor.
3. Wipe up any spilled liquid in the rotor chamber and on the device lid with an absorbent cloth.
4. Clean the rotor chamber and the device lid as described separately.

5.4.5 Emptying the emission condenser

1. There are two possibilities, depending on the design:
 - **The emission condenser is mounted to the side of the device:** Pull the tubing from the connection and empty the liquid into a collection vessel through the upper connection.
 - **The emission condenser is mounted to the front of the device:** Here you can remove the black plug in the vessel with a screwdriver and fit a separate tap before using the device for the first time. You can then empty the liquid directly into a collection vessel via this tap.
2. Dispose of the liquid in accordance with the current legal requirements and regulations for your application.

5.4.6 Switching off the device

1. Leave the device lid open and secure it against closing to allow any remaining liquid to evaporate.
2. Switch off the device at the mains/power switch.

5.5 User instructions on rotors

5.5.1 Rotor A-2-VC

5.5.1.1 Transferring the rotor



CAUTION! Wait for the rotor to stop.

If the plates are fully loaded, it may be possible to open the device lid during the post-run phase of the A-2-VC rotor before the rotor stops.

- ▶ Always wait for the rotor to stop before opening the device lid and removing the plates or tubes.



NOTICE! If handled incorrectly, the rotor may fall.

The swing-bucket rotor may fall if the buckets are used as handles.

- ▶ Remove the buckets before inserting and/or removing a swing-bucket rotor.
 - ▶ Always use both hands to carry the rotor cross.
-

Operation

Concentrator plus/Vacufuge® plus
English (EN)

5.6 Special function**5.6.1 Starting the desiccator function on the device**

With the desiccator function the rotor chamber is evacuated. However, the rotor is not turned.

You can place the micro test tubes directly in the rotor chamber without a rotor or insert them into a rotor.

1. **mode/vent:** select the *D-AQ*, *D-AL* or *D-HV* mode.
2. Then proceed as with the concentrator function (see *Starting the concentration process on p. 38*).

5.6.2 Starting the centrifuge function on the device

With the centrifuge function the rotor is turned. However, the rotor chamber is not evacuated.

1. **mode/vent:** *select the CEFU mode.*
2. Then proceed as with the concentrator function (see *Starting the concentration process on p. 38*).

As no vacuum is applied in this operating mode, the **mode/vent** key does not have any function during operation.

5.6.3 Starting the complete system with gel dryer

On a complete system with a gel dryer connection, a gel dryer can be run in parallel to the operation as a concentrator and/or desiccator or used individually.

**WARNING! Danger of explosion from gas mixtures.**

When running several devices in parallel on a vacuum system or in combination with a gel dryer, an explosive gas mixture may develop in the vacuum system.

- ▶ Observe the solvent properties. Only carry out parallel operations with identical solvents or solvents that evaporate in a non-hazardous manner.
-

1. **mode/vent:** select the *V-AQ*, *V-AL*, *V-HV*, *D-AQ*, *D-AL* or *D-HV* mode.

We recommend the *V-HV* and *D-HV* modes.

If you use the gel dryer individually, you should use the *D-AQ*, *D-AL* or *D-HV* modes in order to protect the drive.

2. In contrast to the concentrator or desiccator function, open the tap of the gel dryer connection before operation (→ knob points in flow direction) and close it after operation.

When the gel dryer is operated without concentrator or desiccator function, the device lid must also be closed as a vacuum cannot be generated otherwise.

3. Then proceed as with the concentrator function (see *Starting the concentration process on p. 38*).

6 Maintenance

6.1 Service



WARNING! Risk of fire or electrical shock

- ▶ Have the centrifuge's electrical safety, especially the paths for the protective connections, checked every 12 months by trained and skilled personnel.

We recommend to have the concentrator and the associated rotors checked by Technical Service during a service at least every 12 months.

6.1.1 Device



The drying of saline aqueous solutions and the long-term exposure of the device components to acids or alkalis will damage the device.



Avoid the use of aggressive chemicals. These include strong and weak alkalis, strong acids, solutions containing mercury, copper and other heavy metal ions, halogenated hydrocarbons, concentrated saline solutions and phenol.

- ▶ For the frequent evaporation of corrosive liquids, apply a thin layer of pivot grease to the rotor and the rotor chamber (order no. int.: 5810 350.050/North America: 022634330).
- ▶ Inspect the device for corrosion.
- ▶ Inspect the motor shaft for damage.

6.1.2 Pump

The chemical-resistant pump of the complete system does not need to be maintained by the user. However, the valves and diaphragms are subject to natural wear and tear.

- ▶ Regularly remove the condensation from the pump and the hose system. To do so, complete a 15-minute run in *D-AQ* mode without samples.
This will prolong the service life of the consumables.
- ▶ Observe any changes in the time required for your application. If you notice any deterioration, have the valves and diaphragms checked by the authorized service.

6.1.3 Rotor and accessories

- ▶ Inspect the rotor and accessories for damage and corrosion.

Maintenance

Concentrator plus/Vacufuge® plus
English (EN)

6.2 Preparing cleaning/disinfection

- ▶ Clean all accessible surfaces of the device and the accessories at least weekly and when contaminated.
- ▶ Clean the rotor regularly. This way the rotor is protected and the durability is prolonged.
- ▶ Furthermore, observe the notes on decontamination (see *Decontamination before shipment on p. 47*) when the device is sent to the authorized Technical Service for repairs.

The procedure described in the following chapter applies to the cleaning as well as to the disinfection or decontamination. The table below describes the steps required on top of this:

Cleaning	Disinfecting/decontamination
<ol style="list-style-type: none"> 1. Use a mild cleaning fluid to clean the accessible surfaces of the device and the accessories. 2. Carry out the cleaning as described in the following chapter. 	<ol style="list-style-type: none"> 1. Choose the disinfection method which corresponds to the legal regulations and guidelines in place for your range of application. For example, use alcohol (ethanol, isopropanol) or alcohol-based disinfectants. 2. Carry out the disinfection or decontamination as described in the following chapter. 3. Then clean the device and the accessories.



If you have any further questions regarding the cleaning and disinfection or decontamination or regarding the cleaning fluid to be used, contact the Eppendorf AG Application Support. The contact details are provided on the back of this manual.

6.3 Cleaning/disinfection**DANGER! Electric shock due to the ingress of liquid.**

- ▶ Switch off the device and disconnect it from the mains/power line before starting cleaning or disinfection.
- ▶ Do not allow any liquids to penetrate the inside of the housing.
- ▶ Do not perform a spray clean/spray disinfection on the housing.
- ▶ Only reconnect the device to the mains/power line when it is completely dry, both inside and outside.

**NOTICE! Damage from the use of aggressive chemicals.**

- ▶ Do not use any aggressive chemicals on the device or its accessories, such as strong and weak bases, strong acids, acetone, formaldehyde, halogenated hydrocarbons or phenol.
- ▶ If the device has been contaminated by aggressive chemicals, clean it immediately using a mild cleaning agent.



NOTICE! Corrosion due to aggressive cleaning agents and disinfectants.

- ▶ Do not use any corrosive cleaning agents, aggressive solvents or abrasive polishes.
- ▶ Do not incubate the accessories in aggressive cleaning agents or disinfectants for longer periods.



NOTICE! Damage from UV and other high-energy radiation.

- ▶ Do not use UV, beta, gamma, or any other high-energy radiation for disinfection.
- ▶ Avoid storage in areas with strong UV radiation.



NOTICE! Danger due to deformed or brittle tubes. Autoclaving at excessive temperatures can lead to plastic tubes becoming brittle and deformed.

This could cause damage to the device and the accessories and sample loss.

- ▶ Observe the temperatures specified by the manufacturer when autoclaving tubes.
- ▶ Do not use deformed or brittle tubes.



Autoclaving

All rotors, rotor lids and adapters can be autoclaved (121 °C, 20 min).

6.3.1 Cleaning and disinfecting the device

1. Open the lid. Switch the device off at the mains/power switch. Disconnect the mains/power plug from the voltage supply.
2. Remove the rotor.
3. Clean and disinfect all accessible surfaces on the device including the mains/power cord using a damp cloth and the recommended cleaning agents.
4. Thoroughly clean the rubber seals of the rotor chamber with water.
5. Rub the dry rubber seal with glycerol or talcum powder to prevent it from becoming brittle. Other components of the device, such as the motor shaft and rotor cone, must not be lubricated.
6. Clean the motor shaft with a soft, dry, lint-free cloth. Do not grease the motor shaft.
7. Leave the lid open when the device is not in use.
8. Only reconnect the device to the mains/power supply if it is fully dry on the inside and outside.

Maintenance

Concentrator plus/Vacufuge® plus
English (EN)

6.3.2 Cleaning and disinfecting the rotor

1. Clean and disinfect the rotors and accessories with the recommended cleaning agents.
2. Rinse the rotor and its accessories thoroughly with water.
3. Place the rotors and accessories on a towel to dry.
4. Clean the rotor cone with a soft, dry, lint-free cloth. Do not lubricate the rotor cone.
5. Place the dry rotor onto the motor shaft.
6. Load the fixed-angle rotor with the cleaned adapters or the swing-bucket rotor with the cleaned buckets and adapters, if necessary.
7. Leave the rotor lid open when the rotor is not being used.

6.4 Cleaning glass breakage

When using glass tubes there is a risk of glass breakage in the rotor chamber. The resulting glass splinters are swirled around in the rotor chamber during centrifugation and have a sandblasting effect on the rotor and accessories. Very small particles of glass can become lodged in the rubber parts (e.g., the motor sleeve, the rotor chamber seal, and the rubber mats of adapters).

**NOTICE! Glass breakage in the rotor chamber**

Glass tubes in the rotor chamber may break if the *g*-force is too high. Broken glass can damage the rotor, accessories and samples.

- ▶ Please note the manufacturer's information on the recommended centrifugation parameters (load and speed).
-

Effects of glass breakage in the rotor chamber:

- Fine black metal abrasion dust in the rotor chamber (with metal rotor bowls).
- The surfaces of the rotor chamber and accessories are scratched.
- The chemical resistance of the rotor chamber is reduced.
- Contamination of samples.
- Wear on rubber parts.

How to proceed in case of glass breakage

1. Remove all splinters and glass powder from the rotor chamber and accessories.
2. Thoroughly clean the rotor and rotor chamber. Thoroughly clean the bores of the fixed-angle rotors, in particular.
3. If required, replace the adapters to prevent any further damage.
4. Regularly check the rotor bores for deposits and damage.
5. Check the rotor regularly for residues or damage.

6.5 Replacing fuses



DANGER! Electric shock.

- ▶ Switch off the device and disconnect the mains/power plug before commencing any service or cleaning operations.

The fuse holder is located between the mains/power cord socket and the mains/power switch.

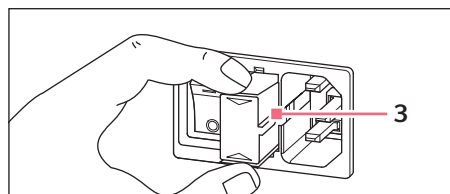
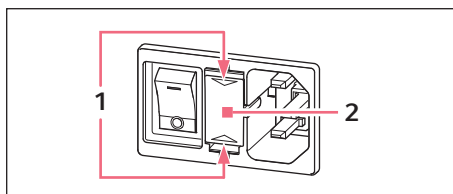

1 Plastic springs

3 Guiding rail

2 Fuse holder

1. Press the upper and lower end of the plastic springs together and pull the fuse holder out completely.
2. Replace faulty fuses and reinsert the fuse holder. Make sure that the guiding rail is positioned correctly.

6.6 Decontamination before shipment

If you are shipping the device to the authorized Technical Service for repairs or to your authorized dealer for disposal please note the following:



WARNING! Risk to health from contaminated device.

1. Observe the information in the decontamination certificate. It is available as a PDF document on our webpage (www.eppendorf.com/decontamination).
2. Decontaminate all the parts you are going to dispatch.
3. Include the fully completed decontamination certificate in the shipment.

Maintenance

Concentrator plus/Vacufuge® plus
English (EN)

7 Troubleshooting

If you cannot remedy an error with the recommended measures, please contact your local Eppendorf partner. The contact address can be found on the Internet at www.eppendorf.com.

7.1 General errors

Problem	Cause	Solution
No display.	No mains/power connection.	▶ Check the mains/power connection.
	Mains/power outage.	▶ Check the fuse of the centrifuge. ▶ Check the mains/power fuse of the lab.
Centrifuge lid cannot be opened.	The rotor is still running.	▶ Wait for the rotor to stop.
	Mains/power outage.	1. Check the fuse of the centrifuge. 2. Check the mains/power fuse of the lab. 3. Activate the emergency lid release.
Centrifuge cannot be started.	The centrifuge lid is not closed.	▶ Close the centrifuge lid.
Centrifuge shakes when it starts up.	The rotor is loaded asymmetrically.	1. Stop the centrifuge and load symmetrically. 2. Restart the centrifuge.
No noticeable evaporation.	Damaged sealing ring in the lid of the device.	▶ Insert new sealing ring(see <i>Others accessories on p. 64</i>).
Pump does not start up.	Pump is overloaded. Thermo switch in the motor winding of the pump triggered.	▶ Let the pump cool down.
Pump does not start up.	Overpressure in the exhaust gas line.	▶ Open the exhaust gas line.
No output.	Long, thin hoses.	▶ Select short hoses with a large cross-section.
No output.	Condensation in the pump.	▶ Let pump run for a few minutes and press the mode/vent key several times.
Temperature value flashes.	Deviation from set value by ± 5 °C.	▶ Let the remaining heat from the previous run cool down. ▶ Reduce the excessive ambient temperature, if applicable.
Temperature value flashes fast.	Deviation from set value by $+ 10$ °C.	▶ Switch off external heat sources (e.g., halogen lamp).
Liquid collects in the hoses.		▶ Activate the ventilation function. ▶ Check the fall of the hoses.

7.2 Error messages

If one of the following error messages appears, proceed as follows:

1. Remove fault (see Remedy).
2. Press the **start/stop** key to clear the error message.
3. If required, continue concentration and/or repeat.

Problem	Cause	Solution
<i>Error 1</i>	Drive fault	▶ Contact Service.
<i>Error 2</i> <i>Error 3</i> <i>Error 4</i>	Drive blocked or stiff.	▶ Move the rotor by hand, remove any obstructions. ▶ Check the max. load of rotor. ▶ Check the rotor mounting.
<i>Error 5</i>	Drive fault	▶ Contact Service.
<i>Error 7</i>	Error in the lid latch.	▶ Contact Service.
<i>Error 8</i>	Fault at the temperature sensor	▶ Contact Service.
<i>Error 9</i>	Electronics fault.	 Caution! The rotor chamber temperature may be > 72°C. ▶ Contact Service.
<i>Error 10</i>	Heater defective.	▶ Contact Service.
<i>Error 12</i> <i>Error 14</i> <i>Error 16</i>	Electronics fault.	▶ Contact Service.
<i>IMBAL</i>	The rotor is loaded asymmetrically.	▶ Load the rotor symmetrically and balance it.

7.3 Opening the device in case of a mains/power outage using the emergency release

If the device lid cannot be opened during a mains/power outage, you can activate the emergency release manually.



WARNING! Risk of injury from rotating rotor.

If the emergency release of the lid is activated, the rotor may continue to rotate for several minutes.

- ▶ Wait for the rotor to stop before activating the emergency release.
- ▶ To check, look through the monitoring glass in the centrifuge lid.



If there is a mains/power outage, the vent valve will open. Before the rotor comes to a standstill, the standard pressure in the rotor chamber will be restored.

1. Disconnect the mains/power plug.
2. Insert a wire (max. 2.5 mm thick, e.g., a paper clip) into the opening on the right-hand side of the housing and push against the noticeable resistance.
This will release the device lid.
3. Open the device lid slightly.
4. Remove the wire.
5. Open the device lid fully.

Troubleshooting

Concentrator plus/Vacufuge® plus
English (EN)

8 Transport, storage and disposal

8.1 Transport

► Only transport the device in its original packaging.

	Air temperature *	Rel. humidity	Atmospheric pressure
General transport	-25 to 60 °C / -10 to 60 °C	10 to 95%	30 to 106 kPa
Air freight	-40 to 55 °C / -10 to 55 °C	10 to 95%	30 to 106 kPa

*) Basic device / complete system

8.2 Storage

	Air temperature *	Rel. humidity	Atmospheric pressure
Device in transport package	-25 to 55 °C / -10 to 55 °C	10 to 95%	70 to 106 kPa
Device without transport package	-5 to 45 °C	10 to 95%	70 to 106 kPa

*) Basic device / complete system

8.3 Disposal

If the product needs to be disposed of, the relevant legal regulations must be observed.

Information on the disposal of electrical and electronic devices in the European Community:

Within the European Community, the disposal of electrical devices is regulated by national regulations based on EU Directive 2012/19/EU pertaining to waste electrical and electronic equipment (WEEE).

According to these regulations, any devices supplied after August 13, 2005, in the business-to-business sphere, to which this product is assigned, may no longer be disposed of in municipal or domestic waste. To document this, they have been marked with the following marking:



Because disposal regulations may differ from one country to another within the EU, please contact your supplier if necessary.

9 Technical data
9.1 Power supply

	5305 Basic device	5305 Complete system
Mains/power connection	230 V, 50 – 60 Hz 120 V, 50 – 60 Hz 100 V, 50 – 60 Hz	230 V, 50 – 60 Hz 120 V, 50 – 60 Hz 100 V, 50 – 60 Hz
Current consumption	2.1 A (230 V) 6.0 A (120 V) 5.2 A (100 V)	1.7 A (230 V) 5.6 A (120 V) 3.8 A (100 V)
Power consumption	max. 500 W (230 V) max. 550 W (120 V) max. 520 W (100 V)	max. 350 W (230 V) max. 400 W (120 V) max. 380 W (100 V)
EMC: Noise emission (radio interference)	100 V: EN 61326-1/EN 55011 – Class B 120 V: CFR 47 FCC Part 15 – Class B 230 V: EN 61326-1/EN 55011 – Class B	
EMC: Noise immunity	EN 61326-1- basic electromagnetic environment	
Overvoltage category	II	
Fuses	230 V > 250 V 4AT HBC 100/120 V > 250 V 6.3AT HBC	
Degree of pollution	2	

9.2 Ambient conditions

Environment:	For indoor use only.
Ambient temperature:	15 to 35 °C
Max. relative humidity:	75 %, non-condensing humidity
Atmospheric pressure:	79.5 kPa – 106 kPa

9.3 Weight/dimensions

	5305 Basic device	5305 Complete system with connection for external device
Dimensions:	Width: 330 mm (12.6 in.) Depth: 372 mm (14.5 in.) Height: 231 mm (9.1 in.)	Width: 330 mm (12.6 in.) Depth: 579 mm (20.9 in.) Height: 290 mm (11.7 in.)
Weight without rotor:	16.5 kg (37.5 lb.)	31.5 kg (68.3 lb.)

Technical data

Concentrator plus/Vacufuge® plus
English (EN)

Rotor weights	Weight [g]
F-45-72-8	245
F-45-70-11	550
F-45-48-11	245
F-45-22-17	710
F-45-24-12	470
F-50-8-16	485
F-50-8-18	480
F-35-6-30	615
F-45-8-17	400
F-40-36-12	330
F-45-36-15	485
F-45-16-20	395
F-40-18-19	635
F-45-12-31	395
F-35-8-24	605
A-2-VC	990

9.4 Noise level

The noise level was measured in a sound measuring room with accuracy class 1 (DIN EN ISO 3745) frontally, at a distance of 1 m from the device and at lab bench height.

Noise level:	< 50 dB(A)
--------------	------------

9.5 Diaphragm vacuum pump for the complete system

Max. current:	1.4/1.6 A (230 V, 50/60 Hz) 3.0 A (120 V, 50 Hz) 3.6/3.8 A (100 V, 50/60 Hz)
Max. drive power:	180 W (230/120/100 V)
Motor protection:	Thermal winding protection
Protection class according to IEC 529:	IP 54
Suction capacity (in accordance with DIN EN 60529; VDE 0470-1):	1.9/2.1 m ³ /h (50/60 Hz)
Achievable ultimate pressure (absolute):	<20 mbar
Max. permissible pressure at the outlet (absolute):	2 bar
Max. differential pressure between the inlet and the outlet:	1 bar
Nominal speed at 50/60 Hz:	1,500/1,800 rpm
Radio interference protection class:	B

Materials of the surfaces that are in contact with media

Inner part of the housing lid:	PTFE, with carbon reinforcement
Head cover, diaphragm clamping disk:	ETFE, with carbon reinforcement
Valve:	FFKM
Diaphragm:	PTFE
Inlet:	ETFE
Outlet:	ETFE
Screw connection:	ETFE
Hose:	PTFE

9.6 Application parameters

Run time:	1 min to 9:59 h, unlimited (∞), adjustable in 1 min. increments.
Rotational speed:	1,400 rpm, not adjustable
Max. relative centrifugal force (RZB or rcf):	248 x g, not adjustable
Max. load:	144 tubes/2 microplates (0.2 to 50 mL)
Permissible density of the material for centrifuging (at max. g-force/speed and max. load):	1.2 g/mL
Emission condenser volume:	280 mL

Technical data

Concentrator plus/Vacufuge® plus
English (EN)

9.7 Service life of accessories**CAUTION! Danger due to material fatigue.**

If the service life is exceeded, it cannot be guaranteed that the material of the rotors and the accessories will withstand the stresses during centrifugation.

- ▶ Do not use accessories that have exceeded their maximum service life.

Eppendorf states the maximum service life of rotors and accessories in cycles and years. The number of cycles is decisive. If determination of the number of cycles is not possible, the service life in years applies.

Each centrifugation run in which the rotor is accelerated and braked is counted as a cycle, independent of the speed and the duration of the centrifugation run.

Unless stated otherwise (in the manual of the centrifuge, indications of the number of cycles on the rotor, in the instructions for use of the rotor), all other rotors and rotor lids can be used over the entire service life of the centrifuge if the following prerequisites are met:

- proper use
- recommended maintenance
- undamaged condition

Accessories	Maximum service life after first initial setup
Adapter	1 year

The date of manufacture is stamped on the rotors and buckets in the format *03/15* or *03/2015* (= March 2015). On the inside of the plastic rotor lids and aerosol-tight caps, the date of manufacture is stamped in the form of a clock ⌚.

9.8 Rotors



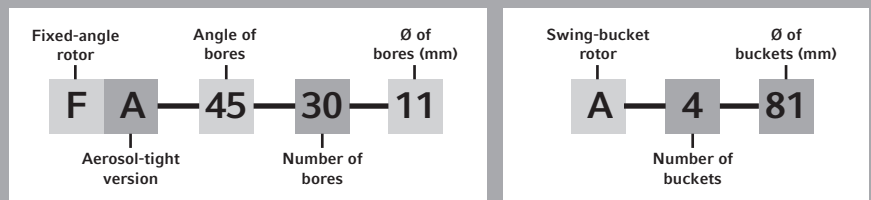

The device can be operated with the following rotors. Before using micro test tubes, please note the manufacturer's recommended specifications with regard to centrifugation stability (max. g-force).

Rotor code:

All Eppendorf® rotors are identified using a simple, alphanumeric format that represents the technical specifications in a uniform series of letters and numbers.



9.8.1 Fixed-angle rotors

Rotor	Tubes / plates	Number of tubes Volume	Dimensions (mm) Ø × L or L × W × H	Max. g-force/ speed	Max. payload per rotor bore ⁽¹⁾
F-45-72-8		72 micro test tubes 0.5 mL	8 × 31	Inner row: 202 × g, outer row: 224 × g/ 1400 rpm	10 g
F-45-70-11		70 micro test tubes 1.5/2.0 mL	11 × 41/ 11 × 47	Inner row: 153 × g, middle row: 202 × g, outer row: 248 × g/ 1400 rpm	15 g
F-45-48-11		48 micro test tubes 1.5/2.0 mL	11 × 41/ 11 × 47	Inner row: 217 × g, outer row: 239 × g/ 1400 rpm	15 g
F-45-22-17		22 micro test tubes 5.0 mL	17 × 59 17 × 67	242 × g/ 400 rpm	10 g
F-45-24-12			24 round-bottom tubes 6.0/8.0 mL	12 × 67 – 100	234 × g/ 1400 rpm
F-50-8-16	8 round-bottom tubes 8.0 - 12.0 mL		16 × 105 – 120	230 × g/ 1400 rpm	70 g
F-50-8-18	8 round-bottom tubes 8.0 - 12.0 mL		18 × 105 – 128	230 × g/ 1400 rpm	70 g
F-35-6-30		6 conical tubes 15 mL	17 × 116 – 123	232 × g/ 1400 rpm	25 g
F-45-8-17		8 conical tubes 15 mL	17 × 118 – 123	239 × g/ 1400 rpm	70 g
F-35-6-30		6 conical tubes 50 mL	29.5 × 116 – 123	232 × g/ 1400 rpm	75 g

Technical data

Concentrator plus/Vacufuge® plus
English (EN)

Rotor	Tubes / plates	Number of tubes Volume	Dimensions (mm) Ø × L or L × W × H	Max. g-force/ speed	Max. payload per rotor bore ⁽¹⁾
F-40-36-12		36 flat-bottom tubes 1.5 mL	12 × 32	215 × g/ 1400 rpm	15 g
F-45-36-15		36 flat-bottom tubes 3.0/5.0 mL	15 × 45 – 48	217 × g/ 1400 rpm	20 g
F-45-16-20		16 flat-bottom tubes 6.5/10.0 mL	20 × 42 – 55	217 × g/ 1400 rpm	45 g
F-40-18-19		18 flat-bottom tubes 10.0 mL	19 × 66	228 × g/ 1400 rpm	35 g
F-45-12-31		12 flat-bottom tubes 20.0 mL	31 × 55	226 × g/ 1400 rpm	55 g
F-35-8-24		8 flat-bottom tubes 25.0 mL	24 × 86 – 90	232 × g/ 1400 rpm	90 g

(1) Maximum payload per rotor bore for adapter + tube + content.

Technical data

Concentrator plus/Vacufuge® plus
English (EN)

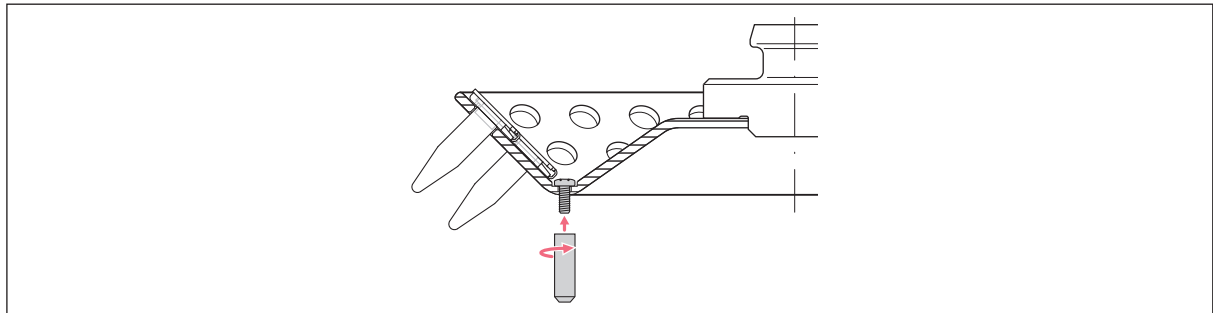
**Rotor F-45-24-12**

- Tube length \leq 75 mm: max. capacity 24 tubes.
- Tube length $>$ 75 mm: max. capacity 12 tubes.

Rotor A-2-VC

- Tubes, PCR-strips and plates without frame can only be used with a suitable work tray (see *Adapters on p. 64*).
- Max. perm. loading height: 27 mm.

Rotor F-35-6-30

- The recommended maximum filling volume for 50 mL conical tubes is 44 mL. If the tubes are filled up to the top, the rotational movement may cause the samples to overflow.

10 Ordering information

10.1 Fuses

Order no. (International)	Order no. (North America)	Description
5301 850.249	022654403	Fuse 4.0 A T (230 V), 2 pieces
5417 341.007	022375831	6,3 A T (230 V), 2 pieces

10.2 Accessories

10.2.1 Rotors

Order no. (International)	Order no. (North America)	Description
5490 034.007	022822080	Rotor F-45-72-8 72 positions for 0.5 mL tubes
5490 032.004	022822047	Rotor F-45-70-11 70 positions for 1.5/2.0 mL tubes
5490 030.001	022822004	Rotor F-45-48-11 48 positions for 1.5/2.0 mL tubes
5490 036.000	022822144	Rotor F-45-24-12 24 positions for 6.0/8.0 mL round-bottom tubes (12 × 67-100 mm)
5490 041.003	022822233	Rotor F-50-8-16 8 positions for 15.0/20.0 mL round-bottom tubes (16 × 105-120 mm)
5490 042.000	022822179	Rotor F-50-8-18 8 positions for 15.0/20.0 mL round-bottom tubes (18 × 105-128 mm)
5490 038.002	022822225	Rotor F-45-8-17 8 positions for 15 mL conical tubes (17 × 118-123 mm)
5490 040.007	022822209	Rotor F-40-36-12 36 positions for 1.5 mL flat-bottom tubes (12 × 32 mm)
5490 035.003	022822128	Rotor F-45-36-15 36 positions for 3.0/5.0 mL flat-bottom tubes (15 × 48 mm)
5490 043.006	022822136	Rotor F-45-16-20 16 positions for 6.5/10.0 mL flat-bottom tubes (20 × 42-55 mm)
5490 037.006	022822161	Rotor F-40-18-19 18 positions for 10.0 mL flat-bottom tubes (19 × 66 mm)
5490 044.002	022822217	Rotor F-45-12-31 12 positions for 20.0 mL flat-bottom tubes (31 × 55 mm)
5490 039.009	022822187	Rotor F-35-8-24 8 positions for 25.0 mL flat-bottom tubes (24 × 86-90 mm)
5490 047.001	022822231	Rotor F-35-6-30 6 positions for 15 mL conical tubes (17 × 116-123 mm) and 50 mL conical tubes (29.5 × 116-123 mm)
5490 045.009	022822241	Rotor A-2-VC incl. 2 buckets

Ordering information

Concentrator plus/Vacufuge® plus
English (EN)

Order no. (International)	Order no. (North America)	Description
5490 048.008	5490048008	Rotor F-45-22-17 22 × 5-mL conical tubes (16 × 60 mm)

10.2.2 Adapters

Order no. (International)	Order no. (North America)	Description
0030 124.235	951010031	Work tray for semi-/unskirted PCR plates, PCR strips and 0.2 mL PCR tubes, for Rotor A-2-VC set of 10 pcs.
0030 124.243	951010049	Frame for work tray for Rotor A-2-VC set of 5 pcs.
5825 706.005	022638963	Adapter used in A-2-VC CombiSlide Adapter, set of 2
5425 715.005 5425 717.008 5425 716.001	022636260 022636243 022636227	Adapter used in F-45-48-11 and F-45-70-11 for 1 PCR tube (0.2 mL, max. Ø 6 mm), set of 6 for 1 micro test tube (0.4 mL, max. Ø 6 mm), set of 6 for 1 sample tube (0.5 mL, max. Ø 6 mm) or 1 Microtainer (0.6 mL, max. Ø 8 mm), set of 6

10.2.3 Others accessories

Order no. (International)	Order no. (North America)	Description
5301 316.005	022822101	Spacer for simultaneous operation of two rotors for F-45-72-8 and F-45-48-11
5301 010.003 5301 033.003	- 022830110	Special plug for external vacuum pump < 400 W 230 V (Germany), different options upon request 120 V, different options upon request
5301 030.004 5301 036.002	022830104 022830112	Solenoid valve for external vacuum pump Only suitable for aqueous and alcoholic solvents. 230 V, 50 – 60 Hz 120 V
5490 030.800	022830520	Rotor feet for F-45-72-8 and F-45-48-11 Set of 3

Declaration of Conformity

The product named below fulfills the requirements of directives and standards listed. In the case of unauthorized modifications to the product or an unintended use this declaration becomes invalid. This declaration of conformity is issued under the sole responsibility of the manufacturer.

Product name:

Concentrator plus, Concentrator plus System

Vacufuge® plus, Vacufuge® plus System

including components

Product type:

Vacuum concentrator

Relevant directives / standards:

2006/42/EC: EN ISO 12100

2014/35/EU: EN 61010- 1, EN 61010- 2- 010, EN 61010- 2- 020

IEC 61010- 2- 010, IEC 61010- 2- 020

UL 61010- 1, CAN/CSA C22.2 No. 61010- 1

2014/30/EU: EN 61326- 1, EN 55011

47 CFR FCC part 15

2011/65/EU: EN 50581

Person authorized to compile

the technical file acc. to 2006/42/EC: Dr. Reza Hashemi
Executive Director Portfolio Management Centrifugation
Eppendorf AG

Hamburg, December 14, 2017



Dr. Wilhelm Plüster
Management Board

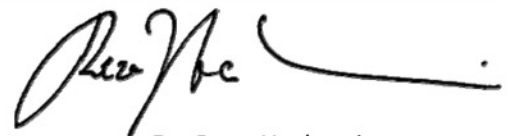

Dr. Reza Hashemi
Portfolio Management

Your local distributor: www.eppendorf.com/contact
Eppendorf AG · Barkhausenweg 1 · 22339 Hamburg · Germany
eppendorf@eppendorf.com

Eppendorf®, the Eppendorf Brand Design and Vacufuge® are registered trademarks of Eppendorf AG, Germany.
All rights reserved, incl. graphics and pictures. Copyright ©2017 by Eppendorf AG.

www.eppendorf.com

ISO
9001
Certified

ISO
13485
Certified

ISO
14001
Certified

CERTIFICATE OF COMPLIANCE

Certificate Number 2018-07-26-E215059
Report Reference E215059-D1012-1/A0/C0-UL
Issue Date 2018-07-26
Issued to: EPPENDORF AG
Applicant Company: BARKHAUSENWEG 1
HAMBURG, 22339 GERMANY
Listed Company: Same as Applicant

**This is to certify that
representative samples of**

Centrifuge
Vacufuge plus and Vacufuge plus System, model 5305

Have been investigated by UL in accordance with the
Standard(s) indicated on this Certificate.

Standard(s) for Safety:

UL 61010-1, 3rd Edition, May 11, 2012, Revised April 29 2016,
CAN/CSA-C22.2 No. 61010-1-12, 3rd Edition, Revision dated
April 29 2016

Additional Standards:

IEC 61010-2-010: 2014 (Third Edition)
IEC 61010 2-020: 2016 (Third Edition)

Additional Information:

See the UL Online Certifications Directory at
www.ul.com/database for additional information.

Only those products bearing the UL Certification Mark should be considered as being covered by UL's
Certification and Follow-Up Service.

Look for the UL Certification Mark on the product.

This is to certify that representative samples of the product as specified on this certificate were tested
according to the current UL requirements.

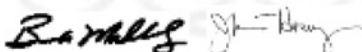

Bruce Mahrenholz, Assistant Chief Engineer, Global Inspection and Field Services, UL LLC
Joseph Hosey, General Manager, Director of Sales – Canada, UNDERWRITERS LABORATORIES OF CANADA INC.

Any information and documentation involving UL Mark services are provided on behalf of UL LLC (UL) or any authorized licensee of UL. For questions, please contact a local UL
Customer Service Representative www.ul.com/contactus



Evaluate Your Manual

Give us your feedback.

www.eppendorf.com/manualfeedback

Your local distributor: www.eppendorf.com/contact

Eppendorf AG · Barkhausenweg 1 · 22339 Hamburg · Germany
eppendorf@eppendorf.com · www.eppendorf.com