



Panthera Series Scientific Instrument Operation Manual



Note

If the equipment is used in a manner not specified by the manufacturer, the protection provided by the equipment may be impaired.



Note

If the equipment is used in a manner not specified by the manufacturer, the protection provided by the equipment may be impaired.

The clear knowledge of this Instruction Manual is needed to operate Motic Panthera Series Microscopes at maximum performance and to ensure safety at all specified operations. Please familiarize yourself with the use of this microscope and pay special attention to the safety hints given in this manual. This Document is not subject of a update routine, please download a newer version from the Motic website, if needed. Keep this instruction manual in reach and easily accessible for future user reference. All Specifications, Illustrations and items in this Manual are subject to changes. Forwarding, duplication or use in other communication of this



WWW.MOTIC.COM

MOTIC HONG KONG LIMITED



English:

Please familiarize yourselves with the Instruction Manual provided in English language. Other Language versions are available as download on Motic web services under the Address:

http://www.motic.com/Panthera/Panthera_Eng_OP.zip

TABLE OF CONTENTS

1.	General notes on instrument safety	5
1.1	General safety notes and Instruction	5
1.2	Instrument safety, FCC and EMC conformity	6
1.3	Transporting, unpacking, storage of the Instrument	7
1.4	Instrument Disposal	7
1.5	Use of the Instrument	7
1.6	Intended use of the Microscope	9
1.7	Instrument warranty	9
2.	Nomenclature	10
2.1	Panthera S	10
2.2	Panthera U / C / L / HD	11
3.	Setting up the instrument	14
3.1	Operating environment	14
4.	Assembling the microscope	17
4.1	Verifying input voltage	17
4.2	Illumination	17
4.2.1	Halogen bulb	17
4.2.2	LED	17
4.3	Stage	17
4.3.1	For Panthera S	17
4.3.2	For Panthera E / U / C / L / HD	18
4.4	Specimen holder	19
4.5	Objectives	19
4.6	Condenser (For Panthera L / HD)	19
4.7	Eyepiece tube	20
4.8	Eyepieces	20
4.9	Filters	20
4.10	Power cord	21

5.	Digital parts (setup and operation)	22
5.1	How to use QR-Link (For Panthera L / HD)	22
5.2	ImagingOnDevice	23
5.2.1	Panthera Series Backside Connection Panel	23
5.3	TeachingOnDevice (Panthera C / HD)	24
5.3.1	Panthera ImagingOnDevice realtime sharing ImagingOnDevice with QR-Link clients	25
5.3.2	ImageRecall	25
6.	Usage of microscope components	26
6.1	Coarse and fine focusing	26
6.2	Coarse focus torque adjustment	26
6.3	Coarse focus quick stop	27
6.4	Stage upper limit stop adjustment	27
6.5	Interpupillary distance adjustment	28
6.6	Diopter adjustment	29
6.7	Adjustment of Brightfield (Panthera C / L)	30
6.7.1	Full Kohler Illumination	30
6.8	Use of aperture diaphragm	31
6.9	Use of field diaphragm (For Panthera C / L only)	31
6.10	Brightness and contrast adjustment	31
6.11	Illumination brightness adjustment	32
6.11.1	Panthera S / E / C	32
6.11.2	Panthera U / L / HD	32
6.12	Restore factory default for intensity (For Panthera U / L / HD only)	32
6.13	Standby mode (For Panthera U / L / HD only)	33
6.14	Adjust the Epi-illumination intensity and transmitted illumination (Panthera U / L / HD only)	33
7.	Photomicrographic procedure	34
8.	Using oil immersion objectives	35

9.	Care and maintenance	36
9.1	Do not disassemble	36
9.2	Cleaning the microscope	36
9.2.1	Lenses and filters	36
9.2.2	Cleaning of painted or plastic components	36
9.3	Disinfecting the Microscope	36
9.4	When not in use	36
9.5	Bulb replacement	37
9.5.1	Replacing the 6V 30W halogen module or the two different LED module (For Panthera C / L / HD)	37
9.5.2	Electrical Specifications	38
10.	Troubleshooting table	39
10.1	Optical	39
10.2	Electrical	40
11.	Selection Of The Power Supply Cord	41
	Microscope terminology	43

1.GENRAL NOTES ON INSTRUMENT SAFETY







1.1 General safety notes and Instruction

Please familiarize yourself with this Operation Manual before starting to use the Instrument.

In case additional information or support is needed, please contact Motic after sales Service.

To ensure safe operation and optimal function of the Instrument, strictly observe the precautions and warnings given in this Operation manual.

Please observe the following indicators:

	CAUTION, Risk of Danger
	This symbol indicates a possible hazard to the user of the instrument.
	CAUTION, Risk of Dangerous heat
	This symbol indicates a possible hazard to the user of the instrument.
	CAUTION, Risk of Electrical Danger
	Disconnect the plug-in power unit from line power before opening the Instrument.
	INFO
	This symbol refers to a useful information or hint.
	Disposal
	This symbol refers you a advice that must be observed under all circumstances
	Instrument ON
	This symbol refers to the switched on (electrical system active) status of the instrument
○	Instrument OFF
	This symbol refers to the switched off (electrical system inactive) status of the instrument
	Risk of Dangerous Electrical Current
	This symbol refers to potential hazardous electrical voltage/current and must be observed at all circumstances!

1.2 Instrument safety, FCC and EMC conformity

This Instrument has been designed, produced and tested in compliance with required safety standards and regulations. UL, CE, FCC, EMC

“Safety of equipment used for *measurement control and laboratory use*”



Panthera Microscope Series Products are in conformity with the requirements of the CE Directive 98/79/EC Annex 1 and carries the CE mark accordingly.

Conform to Class B Noise immunity is in compliance with EN 61326 and EMC and Radio-noise suppression is in compliance with EN 5501 1



The instruments listed in this document are disposed of in compliance with WEEE Directive 2002/96/EC.



Lamp bulbs, LED Modules, lamphouses and Lampdrawers become very hot during and after a period of operation. Risk of burn – Do not touch the lamp during or immediately after period of operation.



Don't pick the microscope up from the bottom during equipment operation.

Proper handling of the microscope will ensure years of trouble free service.

If repair become necessary, please contact your Motic agency or our Technical Service directly.

1.3 Transporting, unpacking, storage of the Instrument

Please observe and follow the safety notes for transportation, unpacking and storage given in this document:



- The microscope is delivered as set, packed into commercial standard plastic and cardboard packaging; Please re-use the original packaging only for any transportation.
- It is advised to keep and use the original packaging for longer storage or return to the manufacturer to avoid losing the warranty.
- At receiving and unpacking the equipment, please verify that all parts specified on the delivery note are present.
- Keep Transport and storage temperatures as specified in this Manual.
- Set the microscope up on a stable worktable with solid and smooth top surface suitable for Instrument use.
- Do not touch optical surfaces.

1.4 Instrument Disposal



Please observe the following safety notes for the disposal of the microscope:

Defective Instruments, accessories and consumables should be disposed in compliance with the provisions of the local law.

1.5 Use of the Instrument

The microscope Instrument as well its accessories must not be used for microscopic techniques or purposes other than those described in this Operating Manual.

Please always observe the following safety notes when using the microscope:



Motic cannot assume any liability for other applications than the intended use, including the included modules and components. This includes to service or repair work that is not carried out by authorized Motic service personnel. In case of non-compliance, all warranty claims and liabilities shall be forfeited.



The microscope Instrument should only be operated by trained personnel who are familiar with this Operation Manual and therefore aware of the possible dangers involved.



This Microscope is a high-precision instrument that can be impaired in its performance or even be destroyed when handled improperly.



This Instrument is equipped with a built-in power supply allowing electric-net voltages to be used in the range between 100 - 240 V \pm 10%, 50/60 Hz. In case of any irregularity on the



electrical system observed, please switch off the Instrument, keep it safe-guarded and consult the Motic after-sales service.



Please only use rated Power cords as described in the Appendix of this Document



Always disconnect the power cable, before opening the instrument and changing the lamp or LED source.



Wait for the lamp to cool down before replacing it and do not touch the new bulb.



The instrument may only be opened by qualified Motic service staff.



The operation of the instrument in explosion-risk environments is not allowed.



Immersion Oil can be harmful. Please only use Motic immersion Oil and follow the safety Instructions given. Immersion oil is to be used for Microscope application only! Please avoid skin contact or swallow or any other use than the intended.

1.6 Intended use of the Microscope

This Microscope is an optical instrument that has been designed to be used to observe and document magnified images of specimens in teaching, routine and research applications.

Do not use this instrument for any other purpose than its intended use.



This Instrument complies with the requirements of directive 98/79/EG concerning in-vitro diagnostic medical devices. CE marking shows the conformity to the directive.

NOTE: This Instrument has been tested and found to comply with the limits for a Class A digital device, pursuant to Part 15 of the FCC Regulations. These limits are designed to provide protection against harmful interference during operation in a commercial environment. This equipment uses and generates frequencies and energy, if not properly installed in accordance with the instruction manual, those may cause interference to radio communications. Operation of this Instrument in a residential area is not permitted.

FCC WARNING: Changes or modifications would void the Instruments FCC compliance and is therefore not permitted.

1.7 Instrument warranty

The Instrument should only be used for microcopy applications mentioned and instructed in this operation manual. Please note the following information on the instruments warranty.

- If possible defects Motic must be notified immediately and steps be taken to minimize damage.
- If notified of such a defect Motic will evaluate the defect and if within warrant, rectify it at his discretion, either by repairing the instrument or by delivering a replacement.
- Natural wear, or defects caused by improper use are not covered by the Instrument warranty.
- Motic shall not be liable for damage caused by faulty operation, negligence or tampering with the Instrument.
- Altering or tampering of the instrument shall lead to a forfeit of all warranty claims

2.NOMENCLATURE

2.1 Panthera S (Binocular Version)

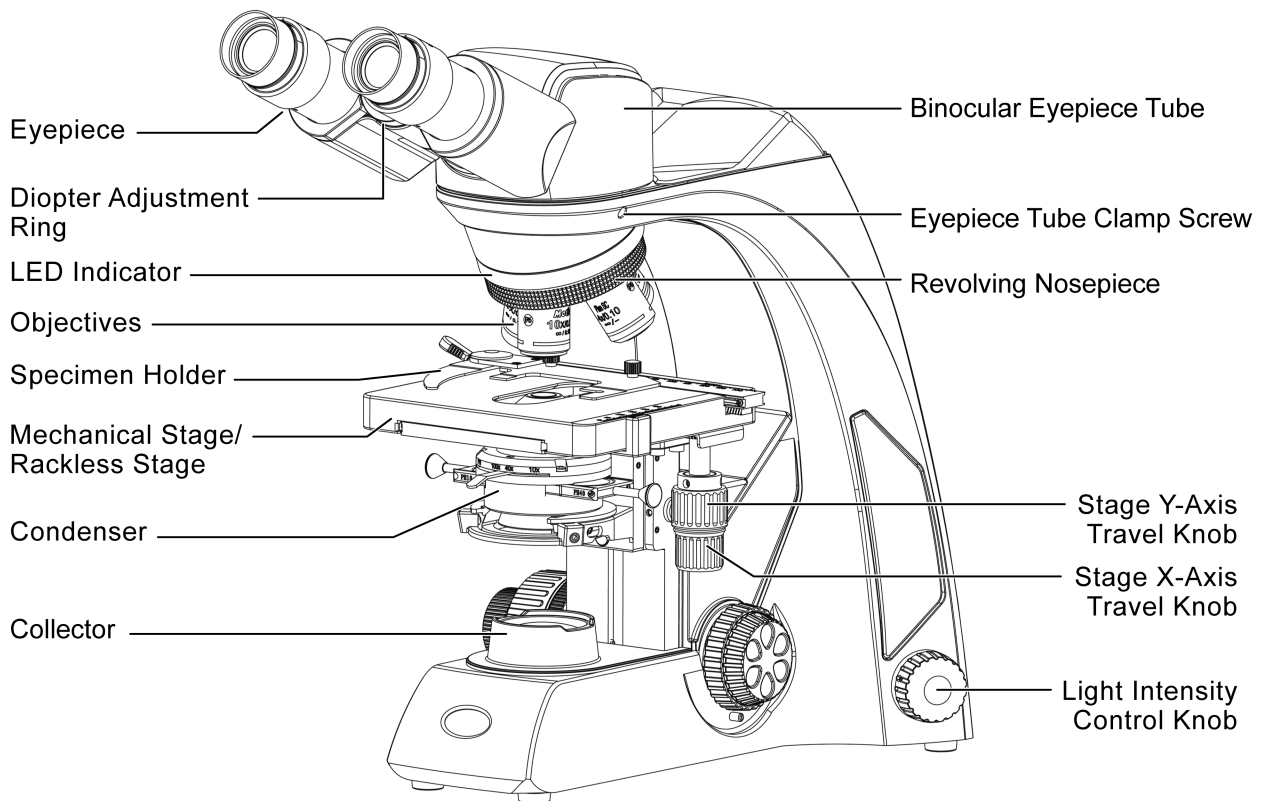
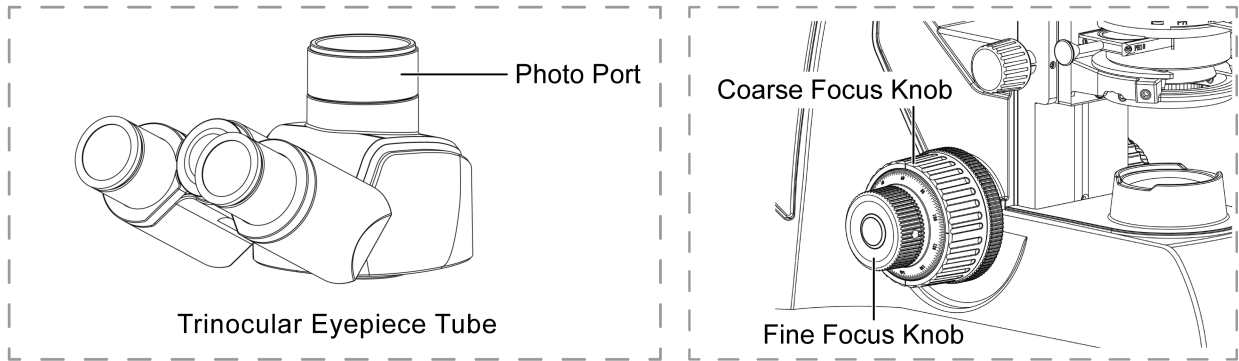

2.2 Panthera U / C / L (Binocular Version) / HD

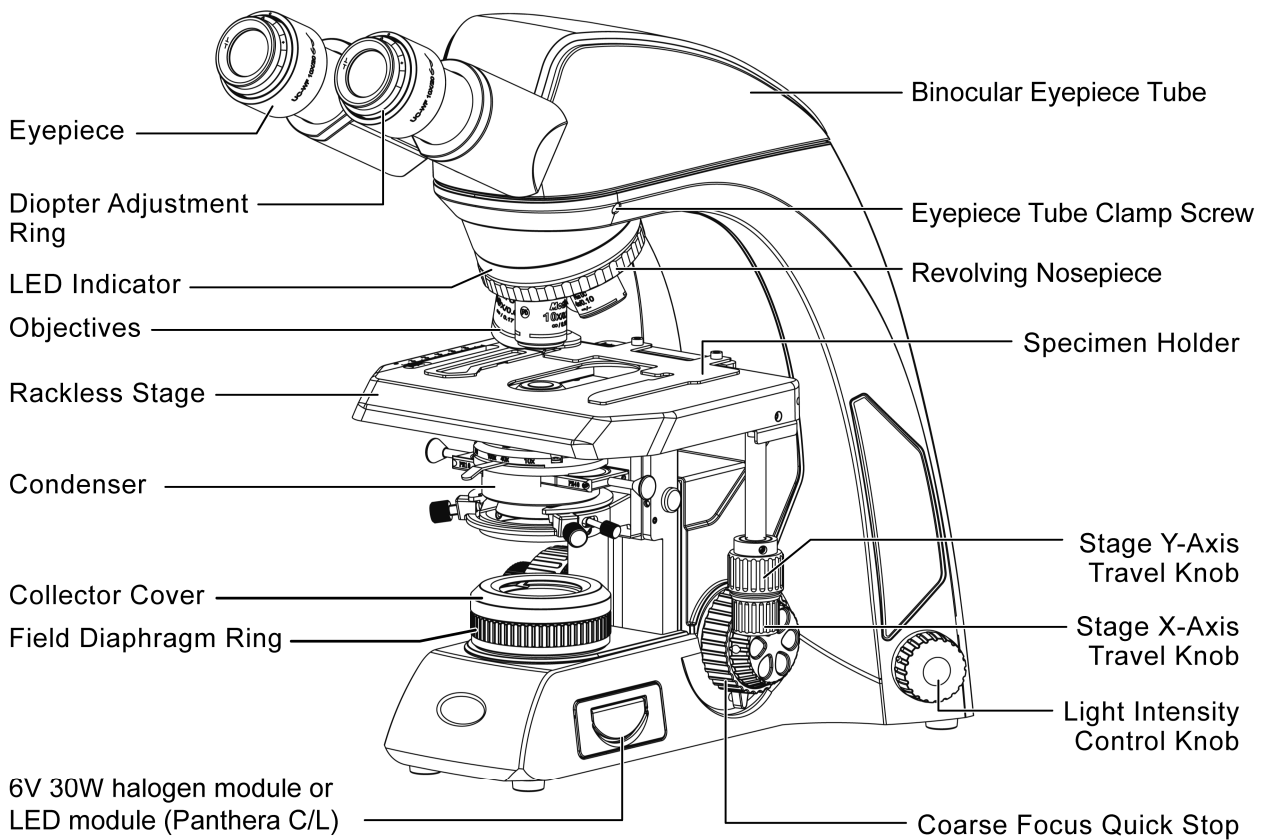
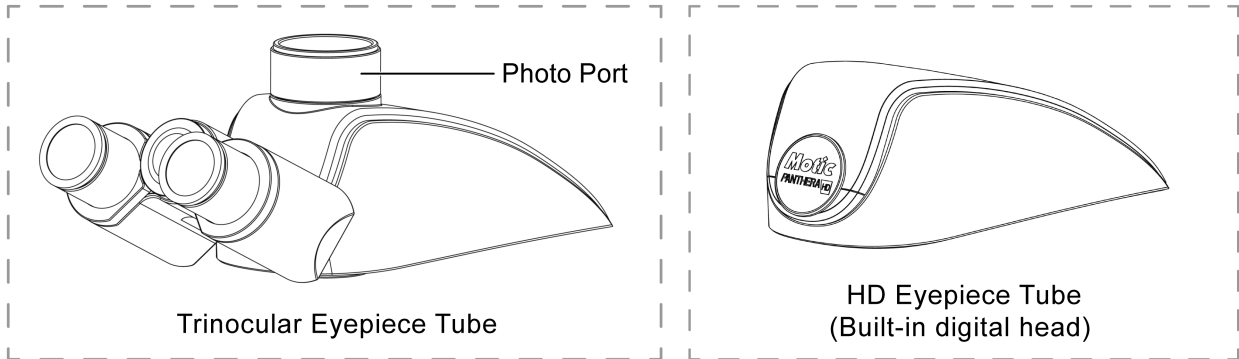

Full Kohler Illumination

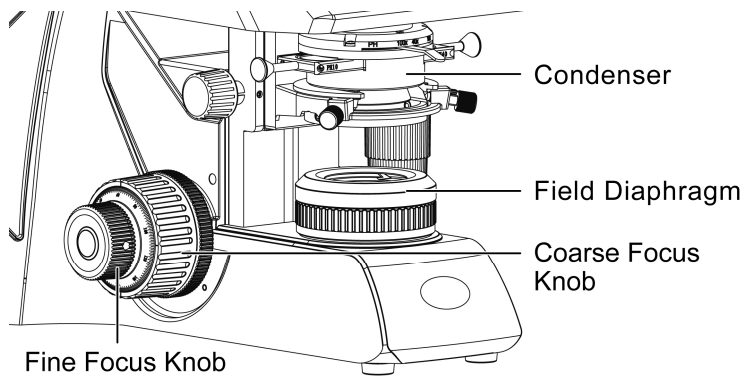

Fixed Kohler Illumination

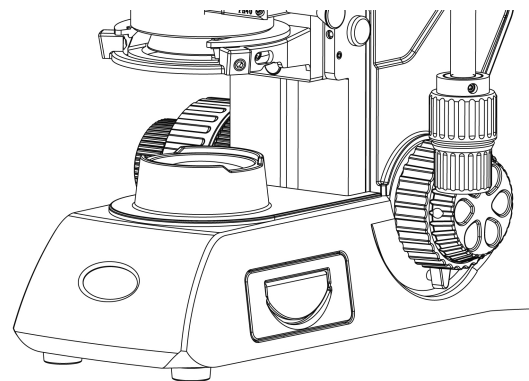

Objective Lenses:

Magnification	N.A.	W.D (mm)
Plan UC 2X	0.05	7.2
Plan UC 4X	0.1	30.5
Plan UC 10X	0.25	17.4
Plan UC 20X	0.45	0.8
Plan UC 40X	0.65	0.6
Plan UC 60X	0.8	0.35
Plan UC 100X/1.25 Oil	1.25	0.16
Plan UC 100X/0.8	0.8	2

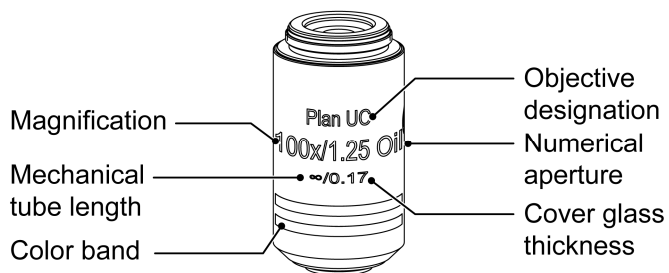

- Working distance WD:** The distance from the cover glass top surface to the nearest point of the objective.
- Numerical aperture NA:** The NA is a performance indicator. The higher NA, the higher the resolving power.
It describes the ability of the lens to collect light under steep entry angles.
- Resolution:** The ability to differentiate two points, or minimum distance under which two points can be differentiated.
- Focal depth:** The area along the optical axis where a focused image appears to be sharp.
If the aperture iris diaphragm is stopped down, the focal depth becomes bigger. As greater the NA of an objective, as shorter the focal depth.
- Field number:** A value that indicates the diameter of the image of the field diaphragm that is formed by the lens in front of it in mm.
- Field of view:** The actual size of the field of view in millimeters in the Eyepiece.
- Total magnification:** Objective magnification multiplied by the eyepiece magnification.

3.SETTING UP THE INSTRUMENT

Avoid placing the instrument in locations exposed to direct sunlight, dust, vibration, high temperature, high humidity and where it is difficult to unplug the power supply cord.

3.1 Operating environment

- Indoor use
- Altitude: Max 2000 meters
- Ambient temperature: 15°C to 35°C
- Maximum relative humidity: 75% for temperature up to 31°C decreasing linearly to 50% relative humidity at 40°C
- Supply voltage fluctuations: Not to exceed $\pm 10\%$ of the normal voltage.
- Pollution degree: 2 (in according with IEC60664)
- Installation / Overvoltage category: 2 (in according with IEC60664)
- Air pressure of 75kPa to 106 kPa
- Avoid frost, dew, percolating water, and rain.

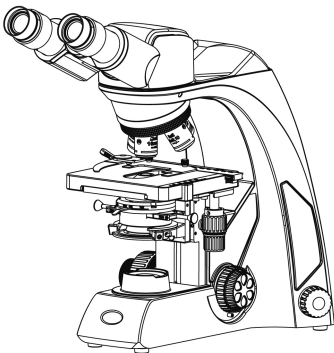

Panthera School

- PowerOnDevice (USB Camera Power, USB Powerpack)
- Cabinet size bino, trino head
- Camera Power devise

Panthera E

- PowerOnDevice (USB Camera Power, USB Powerpack)
- Cabinet size bino, trino head
- Camera Power devise
- Rackless Stage

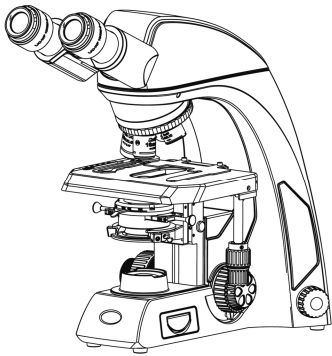

Panthera University

- Light Tracer, digital light control
- Bino, trino, Plan UC optic
- Rackless Stage

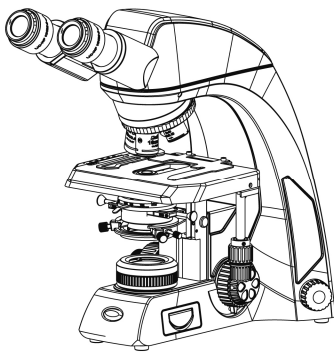

Panthera Classic

- Bino, trino, Plan UC optic
- Rackless Stage

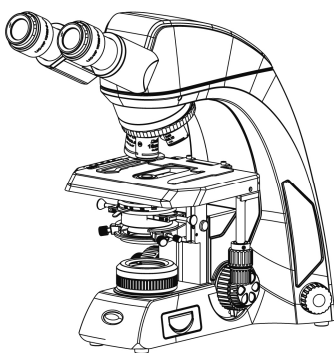

Panthera LifeScience

- Light Tracer, digital light control
- ImagingOnDevice
- QR-Link
- ImageRecall

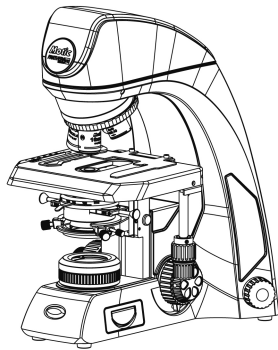

Panthera HD

- SmartLight brightness control
- ImagingOnDevice
- QR-Link
- ImageRecall
- Similar to Panthera L, without Eyepiece



Please familiarize yourself with the instructions given in this Operation Manual.

In case of unresolved questions, please contact Motic after sales Service or consult Motic Webservices for further instructions.

4.ASSEMBLING THE MICROSCOPE

4.1 Verifying input voltage

- The automatic voltage selection works with a broad range of settings, please check the power rating of your country is admitted before the use of the Instrument under chapter specification. However, always use a power cord that is rated for the voltage used in your area and that has been approved to meet local safety standards. Using the wrong power cord could cause fire or equipment damage.
- If using an extension cord, use only a power supply cord with a protective earth (PE) wire.
- In order to prevent electric shock, always turn the power switch on the power supply off before connecting the power cord.

4.2 Illumination

4.2.1 Halogen bulb

- The quartz halogen bulb, provides a nearly complete vis light specimen with high luminance and natural temperature.
- The halogen bulb maintains the same level of brightness and color temperature through its full lifespan.

4.2.2 LED

- LED is more economical and environmental friendly and combines the advantages of low heat and long life span. There are two different color temperature available. High contrast blue/warm color temperature.

4.3 Stage

4.3.1 For Panthera S

- Remove specimen holder for fast hand scanning of slides.
- Left-handed and right-handed operation stages are available for option.

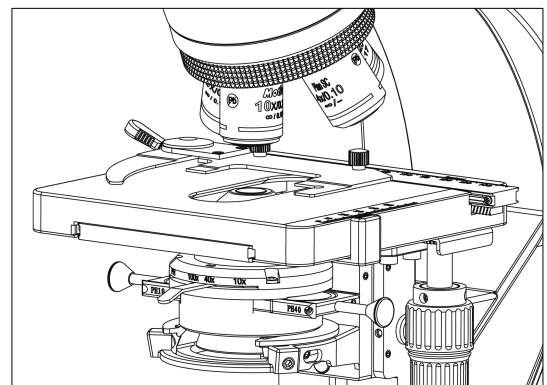

(Fig.1)

4.3.2 For Panthera E / U / C / L / HD

 Panthera E, U, C, L, HD Stage is fitted with a Rackless providing more clearance for the user and avoid the possibility to scratch the users hand.

- Remove specimen holder for fast hand scanning of slides.
- Left-handed and right-handed operation stages are available for option.

Left hand operation stages is available for option. It should be used with the short stage knob for avoiding to interfere the fine focus knob.

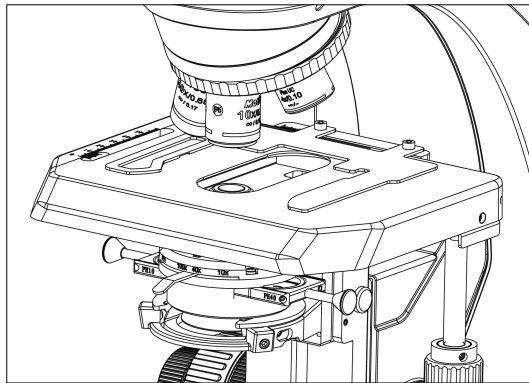

(Fig.2)

- Stage drive Torque adjustment (Optional feature)

The torque of the y-axis and x-axis travel knobs can be adjusted by torque adjusting knobs.

For y-axis to (+) increase or (-) decrease the torque,
turn Knob Y while holding A

For x-axis to (+) increase or (-) decrease the torque,
turn Knob X while holding B

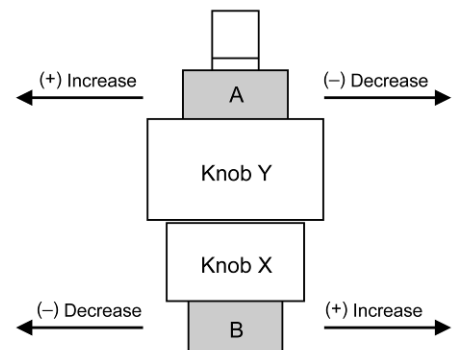

4.4 Specimen holder

- Attach the specimen holder, using the two mounting holes.

4.5 Objectives

- Lower the stage completely. Screw the objectives into the revolving nosepiece so that clockwise rotation of the nosepiece brings the next higher magnification objective into position.

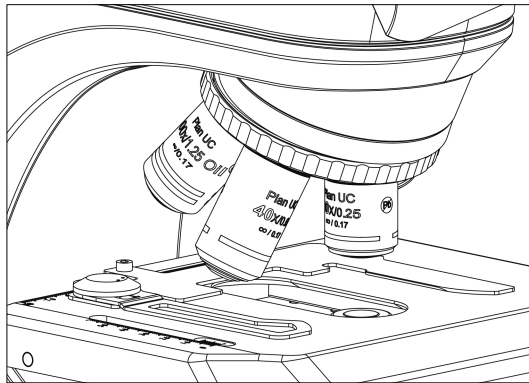

(Fig.3)

4.6 Condenser

- Raise the stage by turning the coarse focus knob.
- Completely lower the condenser carrier by turning the condenser focus knob. (Fig.4-1)
- Insert the condenser into the dovetail mount with aperture scale facing forward towards the user. Secure it with the condenser clamp screw. (Fig.4-2)
- Turn the condenser focus knob to raise the condenser as far as it will go. (Fig.4-1)

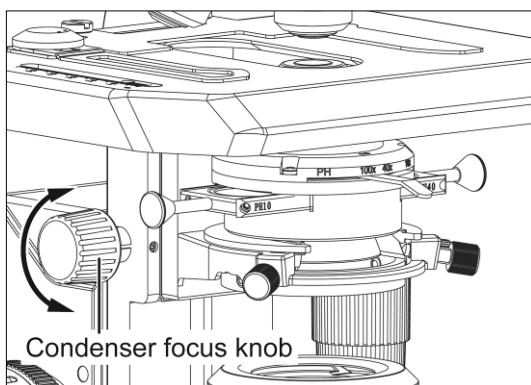

(Fig.4-1)

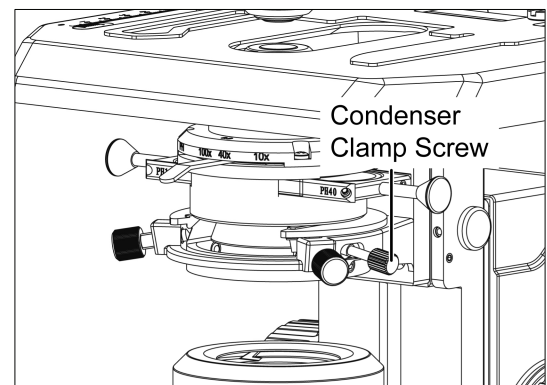

(Fig.4-2)

4.7 Eyepiece tube

- Loosen the eyepiece clamp screw (Fig.5-2). Insert the round dovetail mount on the eyepiece tube into the round dovetail mount on the microscope arm (Fig.5-1). Tighten the eyepiece tube clamp screw to secure the eyepiece tube in place. (Fig.5-2)

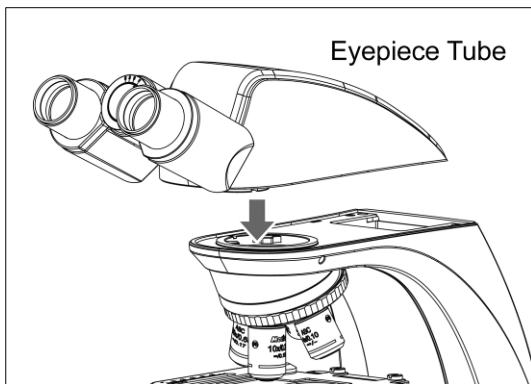

(Fig.5-1)

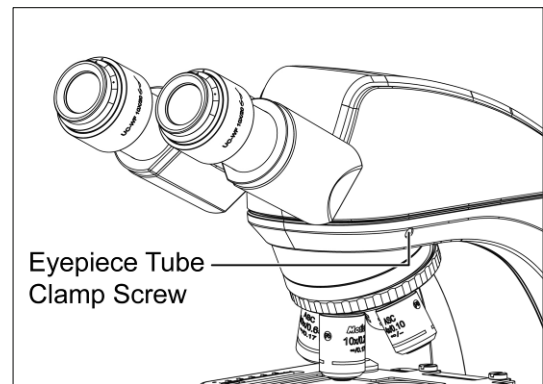

(Fig.5-2)

4.8 Eyepieces

- Use the same magnification eyepieces for both the eyes.
- To secure the eyepiece in the eyepiece sleeve, tighten the clamp screws.
- Twist the eyepiece (anti-clockwise or clockwise) with 20~30 degree (Fig.6.1) and pull the eyepieces gently out when removing the eyepiece. (Fig.6.2)

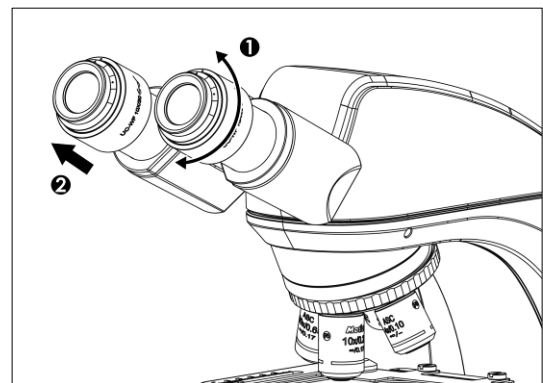

(Fig.6)

4.9 Filters

For Panthera S / E / U:

- Place the filter in the filter holder located around the field lens (Fig.7)

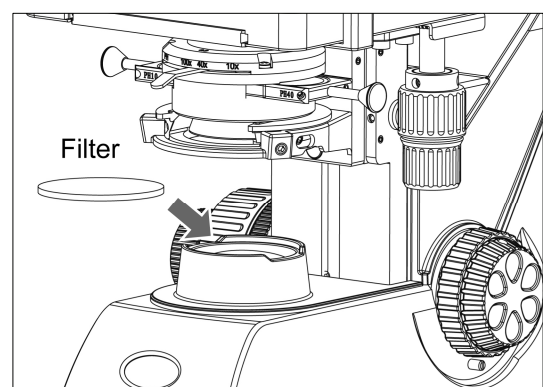

(Fig.7)

For Panthera C / L / HD:

- Remove the collector cover (Fig.8-1) and place the filter in the filter holder located around the field lens (Fig.8-2), screw back the collector cover (Fig.8-1), taking care that dust, dirt and fingerprints do not get on the filter and the field lens.

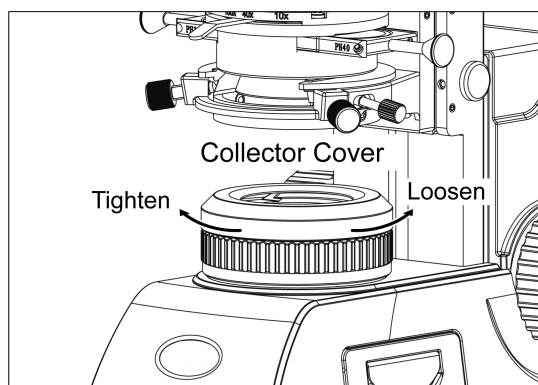

(Fig.8-1)

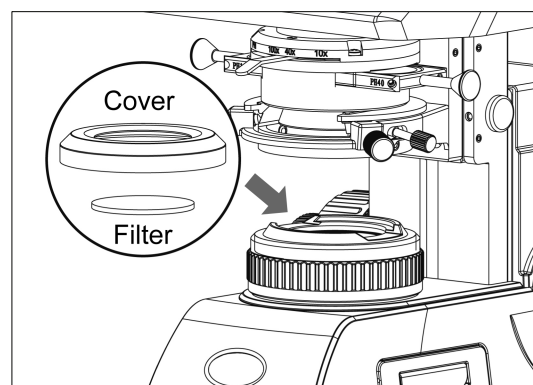

(Fig.8-2)

• **Filter selection:**

Filter	Function
ND2 (T=50%)	For brightness adjustment in photomicrography
ND4 (T=25%)	
ND16 (T=6.25%)	
Blue filter (colour balance filter)	For routine microscopy and photomicrography
Green interference (546nm)	For phase contrast and contrast adjustment with black and white film
HE (didymium filter)	For colour photomicrography of HE stained specimen with tungsten type film

- A diffuser is built into the base of the microscope.

4.10 Power cord

- Connect the socket of the power cord to the AC inlet on the rear of the base of the microscope. Plug in the other end of the cord to an AC outlet with ground conductor.

5.DIGITAL PARTS (SETUP AND OPERATION)

5.1 How to use QR-Link (For Panthera L / HD)

 In case you do not have the Panthera APP yet, please scan the QR-Code on the backside Type Label to download Panthera APP in Android or IOS system, and get connected to the correct APP store via Motic servicing Servers. In case of any issue, please visit the Website <http://www.motic.com/Panthera/app.html>

 Connect the same network with Panthera. If Panthera is hotspot, SSID format is like Motic ***. No password required.

 Use **QR-Link** to connect to **ImagingOnDevice**
To connect to Panthera L Digital Imaging system, open the Panthera APP and scan the QR-code on the top of the Tube head cover. The connection should be activated almost immediately.

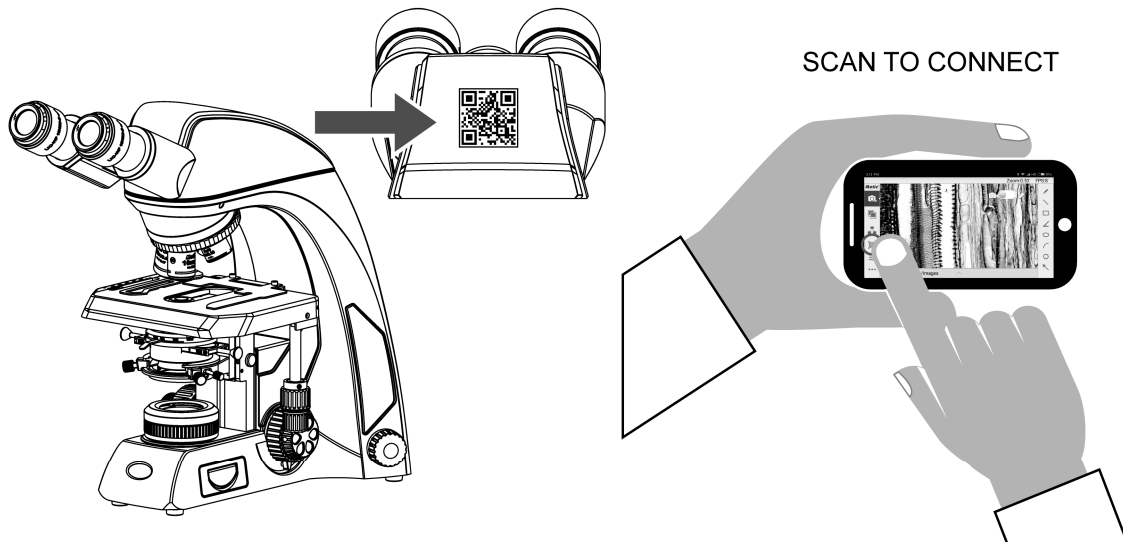

5.2 ImagingOnDevice

5.2.1 Panthera Series Backside Connection Panel

Panthera Series is providing the user with a unseen combination of build in Digital Capabilities.

“Plug in your HDMI Screen, mouse and keyboard and start enjoy the simplicity of working with Motic Panthera Series.”

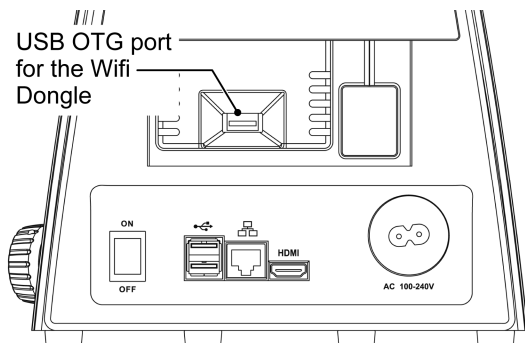

- Direct Connect to Screen
- Projector



- Plug your Mouse or Keyboard
- Take care your data with a USB-Stick

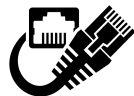

- Connect to remote Location
- Online consultation and Discussion
- Digital Classroom



- Optional WIFI via USB Stick

Panthera L Backpanel Connections

1x	HDMI	Full HD 1080i
1x	Ethernet LAN	1Gbit/s
2x	USB 2.0	Plug and Play
1x	USB 2.0 OTG (Wifi dongle support)	Accessories port



To plug accessories like HDMI Screen, Mouse or Keyboard, turn off the Instrument plug in the accessories and turn the Instrument on again.

5.3 TeachingOnDevice (Panthera C / HD)





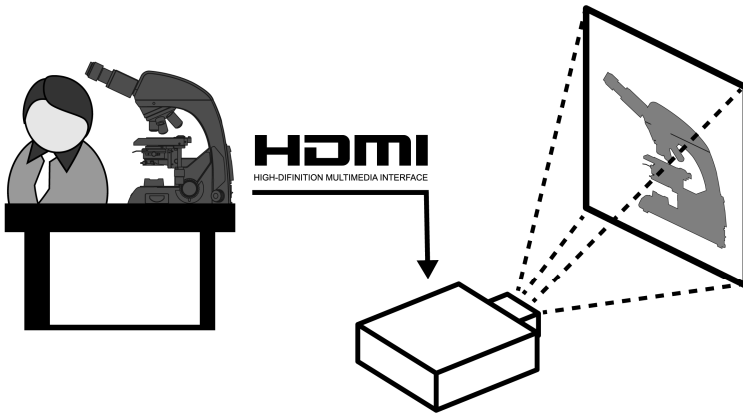

Panthera Microscope Series are providing direct HDMI, USB, LAN Network connectivity. Just plug a HDMI capable Device, mouse and a Keyboard in the backside of the Instrument and start to work.

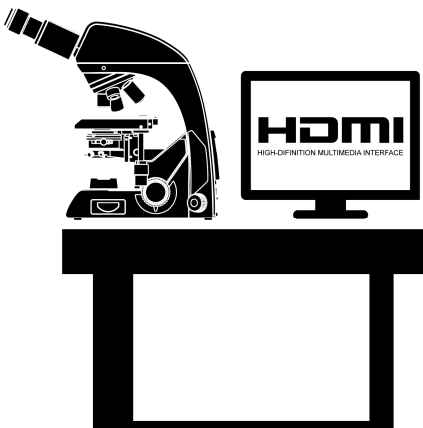

Connect your Panthera Microscope to a touch enabled HDMI Screen and conveniently use a keyboard to enter your reports.

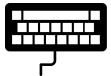

Plug and Play Accessories:

-  • 3 Button Wheel mouse for ease of use and roll to zoom
-  • USB Keyboard, simply connect the Keyboard of your choice
-  • 1Gbit Lan connection port for high speed remote consultaion on Motic DssStore or simply network sharing
-  • Plug your personal USB stick to transport your imagery
-  • Connect your Panthera to the local Wifi or share your image via **QR-Link**.

5.3.1 Panthera ImagingOnDevice realtime sharing **ImagingOnDevice** with **QR-Link** clients

Local: ImagingOnDeviceRemote: QR-Link Clients

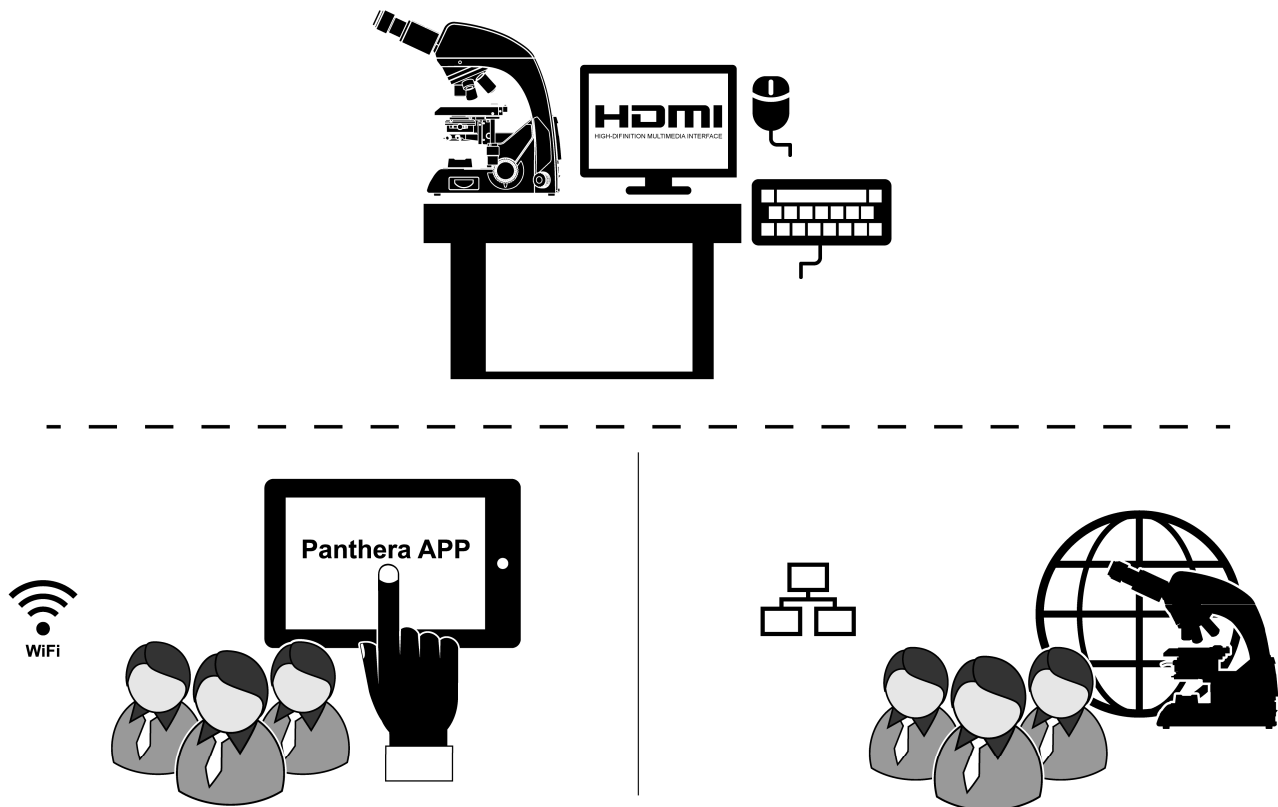

Please refer to “5.1 How to use QR-Link”.

5.3.2 ImageRecall



Panthera ImagingOnDevice stores relevant Data into the EXIF-Header of each Image being made. User can recall the same Illumination settings using the ImageRecall feature in order to allow a easy reconstruction of the before Experiment.

Motic EXIF Header

- Objective Lens Type with Specs
- Brightness Settings
- Camera settings

6.USAGE OF MICROSCOPE COMPONENTS

6.1 Coarse and fine focusing (Fig.9-1)

- Focusing is carried out with the coarse and fine focus knobs at the left and right of the microscope stand.
- The direction of vertical movement of the stage corresponds to the turning direction of the focus knobs.
- One rotation of the fine focus knob moves the stage 0.2mm. The graduation on the fine focus knob is 2 microns.

- **Never attempt either of the following actions, since doing so will damage the focusing mechanism:**
- **Rotate the left and right knob while holding the other.**
- **Turning the coarse and fine focus knobs further than their limit.**

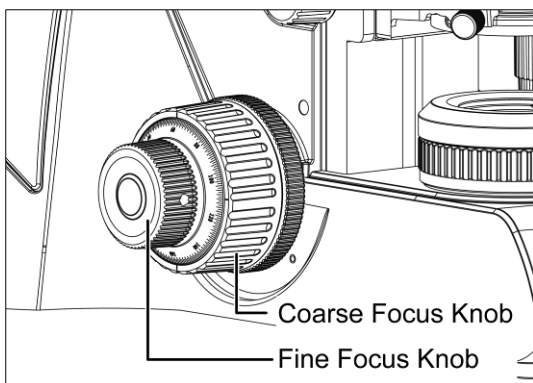

(Fig.9-1)

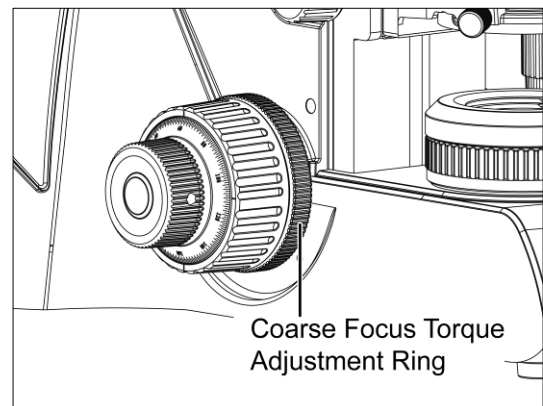

(Fig.9-2)

6.2 Coarse focus torque adjustment (Fig.9-2)

- To increase the torque, turn the torque adjustment ring located behind the left-hand coarse focus knob in the direction indicated by the arrow. To reduce the torque, turn the ring in the direction opposite to that indicated by the arrow.

6.3 Coarse focus quick stop (Fig.10)

- The coarse focus quick stop makes the stage can fixed at any position at which the specimen is in focus i.e. by using the handle to lock the coarse focus knob.
- With the specimen in focus, turn the handle to fix the knob.
- When the coarse focus quick stop is in position, the stage cannot be raised from that position. However, the fine focus knob can move the stage regardless of the limit but will only lower the stage.
- Lower the stage by using the coarse focus knob.

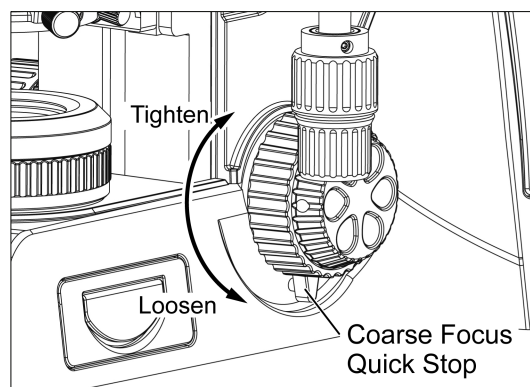

(Fig.10)

6.4 Stage upper limit stop adjustment (Fig.11)

(Upper Stage Limit is preset at the factory; please only adjust if necessary)

- The Stage Upper Limit stop marks the stage position at which the specimen is in focus i.e. by restricting the movement of the coarse focus knob.
- With the specimen in focus, turn the stage upper limit stop knurled ring clockwise until it reaches the stop.
- When the stage upper limit stop is in position, the stage cannot be raised from that position.
- Lower the stage by using the coarse focus knob anticlockwise

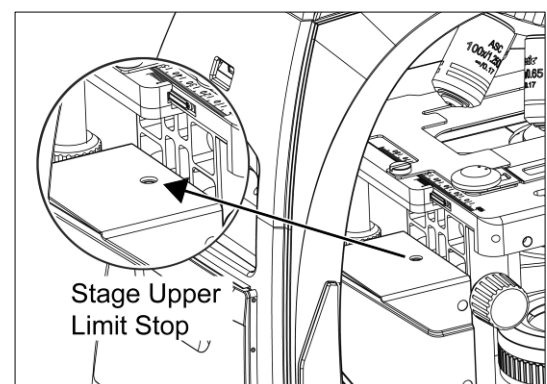

(Fig.11)

6.5 Interpupillary distance adjustment



Every human eye is different, to adjust the Instrument to best performance adjustment can be necessary. Interpupillary distance adjustment enables the user to observe the specimen with both eyes without fatigue

- Before adjusting the interpupillary distance, bring a specimen into focus using the 10x objective.
- Adjust the interpupillary distance so that both the right and left field of view become one.
- This adjustment will enable the user to observe the specimen with both eyes



Panthera Microscopes Series are equipped with a swivelling Binocular to provide the flexibility to adjust the view height for individual viewers convenience (Fig.12).

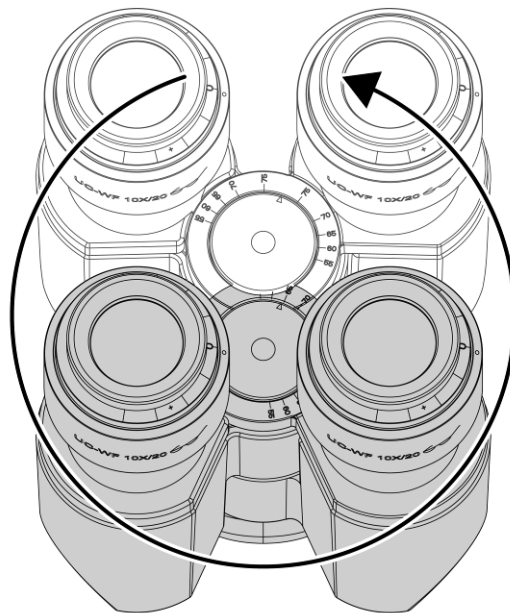

360°swiveling movement, interpupillary distance 50 and 75mm

(Fig.12)

6.6 Diopter adjustment



Every human eye is different, to adjust the Instrument to best performance adjustment can be necessary.

- Set the diopter on both eyepieces to the “0” position.
- Change to 10x Magnification and the image of the specimen into focus using one eye only.
- Change to the other eye and follow below steps.
 - Correct the focus for the second eye by using only the diopter adjustment ring (Fig.13), do not use the coarse / fine focusing knob!
 - Change to a higher magnification to verify the result and if necessary repeat the procedure to match the sharpness for higher magnification.
 - Keep this final diopter position for all magnification / lenses. The diopter position for each user can be recorded from the scale (Fig.13), so it can easily be reset.

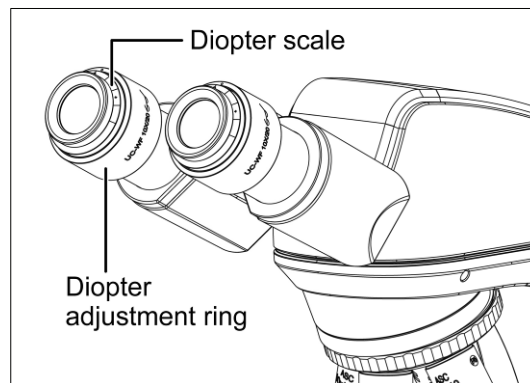

(Fig.13)

6.7 Adjustment of Brightfield (Panthera C / L)

6.7.1 Full Kohler Illumination

- Place as contrast rich specimen slide into the slide holder (1) and swing in a 10x Objective Lens.
- Move any darkfield or phase contrast slider (2) out of the beam path, if equipped with it.
- Adjust the illumination intensity to sufficient brightness (3).
- Turn the knurled condenser height adjustment knob (4) to bring the Abbe condenser up to its top mechanical stop position.
- Look through one eyepiece (5) and turn the focusing drive (7) to focus the 10x lens on the specimen.
- Look through the second eyepiece (6) and if necessary adjust the diopter until the second eyepiece has sharp image.
- Fully open the Aperture diaphragm using the knurled ring Aperture ring the condenser (8). Then close the field diaphragm until it becomes visible, it may appear not sharp by now.
- Adjust the condenser using the centring screws (9) by bringing the light spot of the field diaphragm into the centre of the field of view.
- Open the field diaphragm iris diameter that it just disappears out of the field of view.
- Remove one of the eyepieces and set the aperture diaphragm (10) iris diameter to 2/3rd of it's the field of view.
- Insert the eyepiece back in the tube.

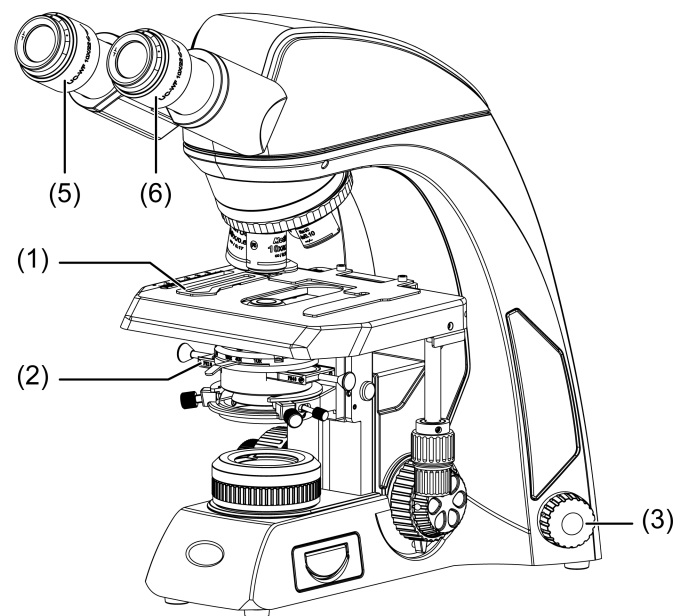
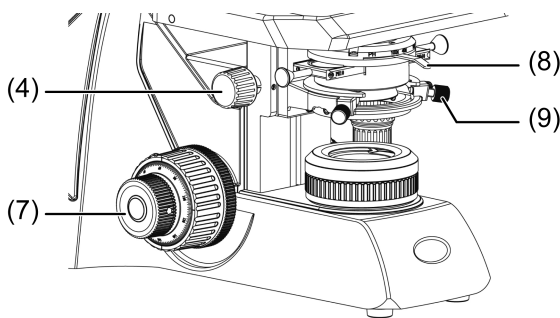

6.8 Use of aperture diaphragm

- The condenser aperture diaphragm is to adjust the numerical aperture (N.A.) of the illuminating system, it serves the resolution of the image, contrast, depth of focus and brightness.
- Stopping it down will lower the resolution and brightness but increase the contrast and depth of focus.
- An image with appropriate contrast can be obtained with an aperture setting that is 2/3 of the objective N.A.



To check the adjustment of the aperture diaphragm:

- Check the condenser aperture scale
- Remove one eyepiece and check the image directly in the eyepiece tube
- Use a centring telescope after removing one of the eyepieces and focusing on the aperture diaphragm.

6.9 Use of field diaphragm (For Panthera C / L only)

- The field diaphragm determines the illuminated area on the specimen. For normal observation, the diaphragm is set slightly larger than the field of view. If the illuminated area is set much larger than the field of view extraneous light will enter the field of view. This will create a flare in the image and lower the contrast.
- The thickness spec of the glass slide must be 1.7mm or less, otherwise the field diaphragm may not be focused on the specimen plane.



On Condensers with swing-in front lens, the diaphragm does not have any effect when the condenser top lens is swung out of the optical path in the Swing-out type condenser. Fully open the field diaphragm, as the N.A. of the illuminating system will be reduced if the diaphragm is excessively stopped down.

6.10 Brightness and contrast adjustment

- Neutral density filters are used for brightness adjustment in routine microscopy and photomicrography.
- For phase contrast and contrast adjustment with black and white film, a Green interference filter (546nm) is recommended.
- An HE (didymium) filter for colour photomicrography, Haematoxylin, Eosin (HE) or Fuchsin stained specimen with tungsten type film is available.

6.11 Illumination brightness adjustment

6.11.1 Panthera S / E / C:

To adjust the Brightness turn the Light Intensity Control Knob and observe the brightness change until the desired brightness has been reached.



There is no Standby or sleep mode available in this model

6.11.2 Panthera U / L / HD:

To adjust the Brightness, turn the Light Intensity Control Knob and observe the brightness change until the desired brightness has been reached.

If the Illumination has not been changed for 3s the actual value will be stored for this Objective magnification.

The light value stored is independently for each objective lens and will be automatically restored once the user returns to the objective lens.

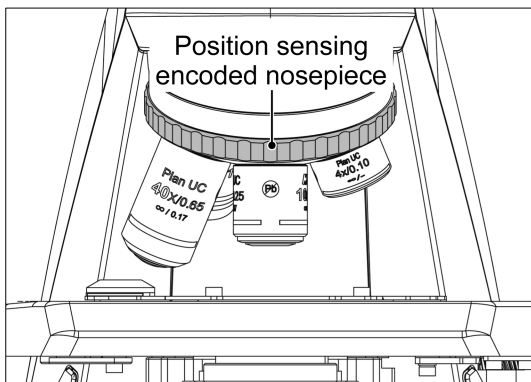

(Fig.14-1)

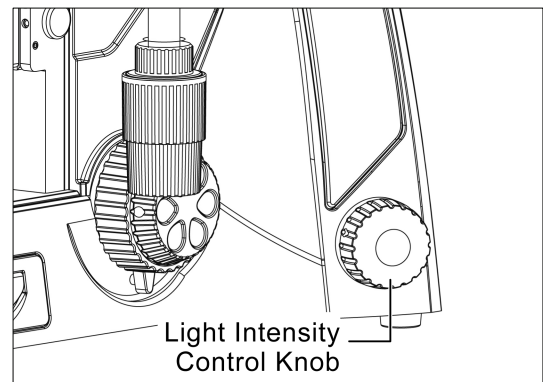

(Fig.14-2)

6.12 Restore factory default for intensity (For Panthera U / L / HD only)

- Turn the Instrument off by switching the main switch on the backside of the Instrument.
Keep the intensity knob pressed and switch instrument on.
Keep holding the intensity control knob for 10s.



Now system is being reset to factory values.



Default intensity value for each objective is chosen to 10% of total brightness

6.13 Standby mode (For Panthera U / L / HD only)



Standby mode self activates after 15 mins of idling time, in order to conserve energy, protect the specimen from overexposure.

- To activate Standby just double click the intensity knob or leave the microscope for 15 minutes, the standby mode turn on.
- Once touch the intensity knob or nosepiece, standby model turn off. Intensity will be adjusted to the last memorized status.



LED Indicator shows breathing status, to indicate its in standby

6.14 Adjust the Epi-illumination intensity and transmitted illumination (Panthera U / L / HD only)

Switch to the Epi-illumination intensity, push and turn up the intensity knob.

Push and turn down the intensity knob, then Epi-illumination is turned off. It switch to the transmitted illumination.

7. PHOTOMICROGRAPHIC PROCEDURE

- To ensure vibration free operation, set the microscope on a sturdy vibration free table or a bench with a vibration proof device.
- Pull the optical path selection lever of the trinocular eyepiece tube all of the way out to the limit, the ratio of light entering the observation tube and standard phototube will be 20:80.
- For the same total magnification, select a combination of the highest possible objective magnification and lowest possible projection lens magnification to achieve the utmost image definition and contrast.
- To ensure optimal illumination, check the position and centring of the lamp and position of the condenser.
- Select a blue filter for routine application. An additional colour-compensating filter can also be used depending on the colour rendition.
- Adjusting the field diaphragm is important for the purpose of limiting extraneous light that may cause flare and lower the contrast. Stop down the diaphragm to achieve an illuminated area slightly larger than that of the field of view.
- A change of depth of focus, contrast and resolution of image is attainable with an aperture setting that is $\frac{2}{3}$ of the objective N.A.
- For specific photomicrographic procedures, refer to the manual of the specific camera being used.

8.USING OIL IMMERSION OBJECTIVES

- Oil immersion objectives are labelled with the additional engraving “Oil” and are to be immersed in oil between the specimen and the front of the objective.
- The immersion oil supplied by Motic is synthetic, non-fluorescing and non-resining oil, with a refractive index of 1.515.
- The small bottle of oil supplied with every immersion objective facilitates application of the oil to the cover slip.
- Remove any air bubbles in the nozzle of the oil container before use.
- Immersion oil must be used sparingly. After the examination, the oil should be wiped off the objective with a lens cleaning tissue and the residual film removed with soft cloth moistened with petroleum benzene or absolute alcohol.
- Locate the field of interest with a lower magnification objective. Swing the objective out of the light path, and add one drop of immersion oil over the site of the specimen. Swing in the oil immersion objective. There should be a small column of oil from the cover slip to the objective lens. Use the fine focus to make the image sharp.
- At operating with Immersion Oil, the space between Objective and Cover glass must be free of any Air bubbles

9.CARE AND MAINTENANCE

9.1 Do not disassemble

- Disassembly may significantly effect the performance of the instrument, and may result in electric shock or injury and will void the terms of the warranty.
- Never attempt to dismantle any parts other than described in this manual. If you notice any malfunction, contact your nearest Motic representative.

9.2 Cleaning the microscope

9.2.1 Lenses and filters

- To clean lens surfaces or filters, first remove dust using an air blower. If dust still persists, use a soft /clean brush or gauze.
- A soft gauze or lens tissue lightly moistened with Isopropyl alcohol should be used to remove grease or fingerprints.
- Use isopropyl alcohol) to remove immersion oil from objective lenses.



Warning: alcohol is highly flammable liquid, be careful handling around open flame and always observe the local security advise how to handle such substances

9.2.2 Cleaning of painted or plastic components

- Do not use organic solvents (thinners, alcohol, ether, etc.). Doing so could result in discolouration or in the peeling of paint.
- For stubborn dirt, moisten a piece of gauze with diluted detergent and wipe clean.
- For plastic components, only moisten a piece of gauze with water and wipe clean.

9.3 Disinfecting the Microscope

- Follow the standard procedures for your laboratory.

9.4 When not in use

- When not in use, cover the instrument with vinyl dust cover and store in a place low in humidity where mould is not likely to form.
- Store the objectives, eyepieces and filters in a container or desiccators with drying agent.
- Proper handling of the microscope will ensure years of trouble free service.
- If repair becomes necessary, please contact your Motic agency or our Technical Service direct.

Note:

- If equipment is used in a manner not specified by the manufacturer, the warranty may be void.
- To avoid getting wet, do not use the microscope near water.

9.5 Bulb replacement



The lamp and the lamphouse become very hot during and after a period of operation.

Risk of burn – Do not touch the lamp during or immediately after period of operation.

Make sure the lamp has cooled sufficiently before attempting to replace the lamp.

- In order to prevent electric shock always turn the power switch off and unplug the power cord before installing or replacing the bulb.

9.5.1 Replacing the 6V 30W halogen module or the two different LED module

(For Panthera C / L / HD)

- Lift up the cover of illumination module. (Fig.15-1)
- Loosen the fastening screw of the illumination module. In doing so, slightly press the screw against the spring and turn it by 90° (counter clockwise). (Fig.15-2)
- Pull the illumination module out of the stand. (Fig.15-3)
- If the stand is equipped with a 6V 30W halogen lamp, remove the halogen lamp from the lamp carrier and insert the new halogen lamp. Do not touch the new lamp with naked fingers and this will reduce lamp life.
- If the stand is equipped with an LED lamp replace the complete illumination module including the LED.
- Push the illumination module back into the stand and lock it by means of the screw. In doing so, slightly press the screw against the spring and turn it by 90° (clockwise). (Fig.15-4)

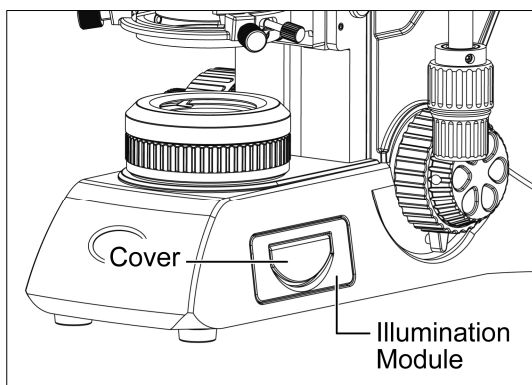

(Fig.15-1)

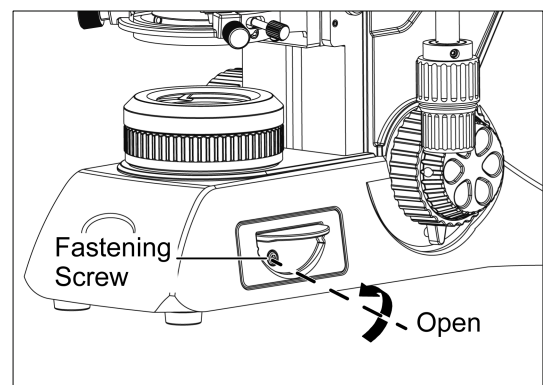

(Fig.15-2)

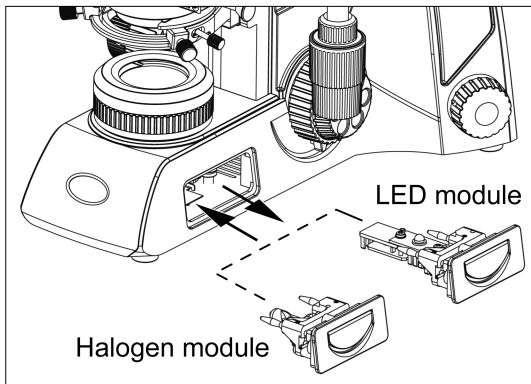

(Fig.15-3)

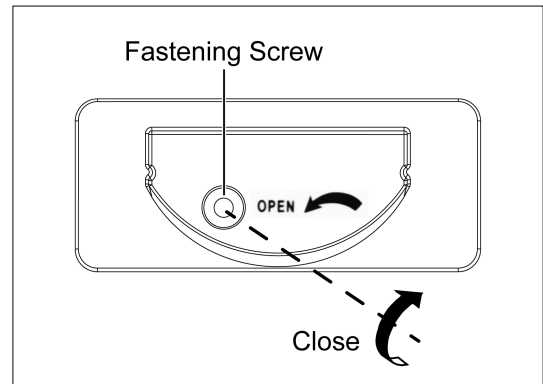

(Fig.15-4)

9.5.2 Electrical Specifications:

A. Panthera S / E:

Camera USB Output: 5V / 0.5A
 Input: AC100~240V, 50~60Hz 0.55A
 Bulb: 0.5W LED, color temperature: 5700K

B. Panthera U:

Camera USB Output: 5V / 0.5A
 Input: AC100~240V, 50~60Hz 0.55A
 Output: DC12V 1A
 Bulb: 3 W LED
 LED module, high color temperature: 5500K ~ 6000K
 LED module, low color temperature: 3000K ~ 3500K

C. Panthera C:

Camera USB Output: 5V / 0.5A
 Input: AC100~240V, 50~60Hz 1.2A
 Bulb: 3W LED or 6V 30W Halogen
 LED module, high color temperature: 5500K~ 6000K
 LED module, low color temperature: 3000K ~ 3500K

D. Panthera L / HD:

Input: AC100~240V, 50~60Hz 1.2A
 Output: DC 12V 1A
 Bulb: 3W LED or 6V 30W Halogen
 LED module, high color temperature: 5500K~ 6000K
 LED module, low color temperature: 3000K ~ 3500K

10.TROUBLESHOOTING TABLE

As you use your microscope, you may occasionally experience a problem.

The troubleshooting table below contains the majority of frequently encountered problems and the possible causes.

10.1 Optical

Problem	Possible Cause
Vignetting or uneven brightness in the field of view or field of view only partially visible	Lamp not installed properly
	Lamp not centred
	Diffuser is in intermediate position
	Condenser not mounted correctly
	Condenser is not centred
	Condenser is set too low
	Condenser top lens not fully swung in/out
	Field diaphragm closed too far
	Aperture diaphragm closed too far
	Improper condenser objective combination
	Revolving nosepiece not clicked into position
	Trinocular eyepiece tube optical path selector lever in intermediate position
Dust or dirt in the field of view	Aperture diaphragm closed too far
	Condenser is set too low
	Dust or dirt on specimen surface
	Dust or dirt on field lens, filter, condenser or eyepiece
Poor image (low contrast or resolution)	Condenser is set too low
	Aperture diaphragm closed too far
	No cover glass
	Too thick or thin cover glass
	Immersion oil not used with oil immersion lens
	Air bubbles in immersion oil
	Specified immersion oil not used
	Immersion oil on dry objective
	Greasy residue on eyelens
Incorrect illumination	

Unequal focus	Stage installed on inclined plane
	Specimen holder not fixed securely on stage
	Specimen not secured in position
Image tinged yellow	Lamp voltage is set too low
	Blue filter is not being used
Focusing is not possible with high magnification objectives	Slide is upside down
	Cover glass is too thick
High magnification objectives strike the specimen when changing over from low to high magnification	Slide is upside down
	Cover glass is too thick
	Eyepiece diopter not adjusted
Insufficient parfocality of objectives	Eyepiece diopter not adjusted
No cohesion of binocular image	Magnification or field of view of left and right eyepieces differ
	Interpupillary distance not adjusted
	Eyepiece diopter not adjusted
Eye strain or fatigue	Interpupillary distance not adjusted
	Diopter adjustment not made
	Field of view of left and right eyepiece differ
	Inadequate illumination

10.2 Electrical

Lamp does not light	Power supply not plugged in
	Lamp not installed
	Lamp burnt out
Inadequate brightness	Specified lamp not being used
Lamp blows out immediately	Specified lamp not being used
Lamp flickers	Connectors are not securely connected
	Lamp near end of service life
	Lamp not securely plugged into socket

11. SELECTION OF THE POWER SUPPLY CORD

Motic Instruments are certified and tested for safety and environmental conformity. Only power supply cords which conform with below listed certification marks and countries are applicable.

CAUTION : Do not use non-approved power cord for Motic products, Motic can no longer warrant the electrical safety of the equipment.

Table 1 Certified Cord

	Specifications
Voltage Rating	125V AC (for 100-120V AC area) or, 250V AC (for 220-240V AC area)
Current Rating	6A minimum
Temperature Rating	60 C minimum
Length	3.05 m maximum
Fitting Configuration	Grounding type attachment pull cap Opposite terminates in molded-on EC con-figuration appliance coupling.

The power supply cord should be certified by one of the agencies listed in Table 1, or comprised of cordage marked with an agency marking per Table 1 or marked per Table 2. The fittings are to be marked with at least one of agencies listed in Table 1..





















Country	Agency	Certification Mark	Country	Agency	Certification Mark
Argentina	IRAM		Italy	IMQ	
Australia	SAA		Japan	JQA, JET, TÜV, UL-APEX/MITI	 
Austria	OVE				
Belgium	CEBEC		Netherlands	KEMA	
Canada	CSA		Norway	NEMKO	
Denmark	DEMKO		Spain	AEE	
Finland	FEI		Sweden	SEMKO	
France	LTTE		Switzerland	SEV	
Germany	VDE		United Kingdom	ASTA BSI	 
Ireland	NSAI		U.S.A	UL	

Table 2 HAR Flexible Cord

Approval Organizations And Cordage Harmonization Marking Methods

Approval Organization	Printed or Embossed Harmonization Marking (May be located on jacket or insulation of internal wiring)		Alternative Marking Utilizing Black-Red-Yellow Thred (Length of color section in mm)		
			Black	Red	Yellow
Comite Electrotechnique Belge (CEBEC)	CEBEC	<HAR>	10	30	10
Verband Deutscher Elektrotechniker (VDE) e.V.	<VDE>	<HAR>	30	10	10
Union Technique de Electricity	USE	<HAR>	30	10	30
Instituto Italiano del Marchio di Qualita (IMQ)	IEMMEQU	<HAR>	10	30	50
British approvals Service for Electric Cables (BASEC)	BASEC	<HAR>	10	10	30
N.V. KEMA	KEMA-KEUR	<HAR>	10	30	30
SEMKO AB Svenska Elektriska Matenelkontrollanstalter	SEMKO	<HAR>	10	10	50
Österreichisher Verband fur Elektrotechnik (ÖVE)	<ÖVE>	<HAR>	30	10	50
Danmarks Elektriske Materialkontroll (DEMKO)	<DEMKO>	<HAR>	30	10	30
National Standards Authority of Ireland (NSAI)	<NSAI>	<HAR>	30	30	50
Norges Elektriske Materiellkontroll (NEMKO)	NEMKO	<HAR>	10	10	70
Asociacio Electroteca Y Electronica Espanola EE)	<UNED>	<HAR>	30	10	70
Hellenic Organization for Standardization	ELOT	<HAR>	30	30	70
Institute Portages da Qualidade (IPQ)	np	<HAR>	10	10	90
Schweizerischer Elektro TechnischerVerein (SEV)	SEV	<HAR>	10	30	90
Elektriska Inspektoratet	SETI	<HAR>	10	30	90

MICROSCOPE TERMINOLOGY

Abbe Condenser

A two-lens sub-stage condenser located below the stage of a microscope and functions to collect light and direct it onto the object being examined. Its high numerical aperture makes it particularly suited for use with most medium- and high-magnification objectives.

Aperture, Numerical (N.A.)

The numerical aperture is an important factor determining the efficiency of the condenser and objective. It is represented by the formula: (N.A. = $n \sin \alpha$), where n is the refractive index of a medium (air, water, immersion oil etc.) between the objective and the specimen or condenser, and α is half of the maximum angle at which light enters or leaves the lens from or to a focused object point on the optical axis.

Cover Glass Thickness

Transmitted light objectives are designed to image specimens that are covered by a thin cover glass (**cover slip**). The thickness of this small glass piece is now standardized at 0.17 mm for most applications.

Diaphragm, Condenser

A diaphragm, which controls the effective size of the condenser aperture. A synonym for the condenser illuminating aperture diaphragm.

Magnification

The number of times by which the size of the image exceeds the original object. Lateral magnification is usually meant. It is the ratio of the distance between two points in the image to the distance between the two corresponding points in the object.

Micrometer: *um*

A metric unit of length measurement
= 1×10^{-6} meters or 0.000001 meters

Nanometer (nm)

A unit of length in the metric system equal to 10^{-9} meters.

Phase-contrast (microscopy)

A form of microscopy, which converts differences in object thickness and refractive index into differences in image amplitude and intensity.

Real Viewfield

The diameter in millimetres of the object field.

$$\text{Real Viewfield} = \frac{\text{Eyepiece Field of View}}{\text{Objective Magnification}}$$

Example:

Eyepiece field of view = 20mm
Objective magnification = 10X
Diameter of the object field = 20/10
= 2.0mm

Diopter adjustment

The adjustment of the eyepiece of an instrument to provide accommodation for the eyesight differences of individual observers.

Depth of Focus

The axial depth of the space on both sides of the image plane within which the image is sharp. The larger the N.A. of objective, the shallower the depth of focus.

Field of View (F.O.V.)

That part of the image field, which is imaged on the observer's retina, and hence can be viewed at any one time. The field of view number is now one of the standard markings of the eyepiece.

Filter

Filters are optical elements that selectively transmit light. It may absorb part of the spectrum, or reduce overall intensity or transmit only specific wavelengths.

Immersion Oil

Any liquid occupying the space between the object and microscope objective. Such a liquid is usually required by objectives of 3-mm focal length or less.

Resolving Power

A measure of an optical system's ability to produce an image which separates two points or parallel lines on the object.

Resolution

The result of displaying fine details in an image

Total Magnification

The total magnification of a microscope is the individual magnifying power of the objective multiplied by that of the eyepiece.

Working Distance

This is the distance between the objective front lens and the top of the cover glass when the specimen is in focus. In most instances, the working distance of an objective decreases as magnification increases.

X-axis

The axis that is usually horizontal in a two-dimensional coordinate system. In microscopy X-axis of the specimen stages is considered that which runs left to right.

Y-axis

The axis that is usually vertical in a two-dimensional coordinate system. In microscopy Y-axis of the specimen stages is considered that which runs front to back.



NO.: 1300901110501

Motic Hong Kong Limited (Hong Kong)

Unit 2002, L20, Tower Two, Enterprise Square Five, 38 Wang Chiu Road, Kowloon Bay, Kowloon, Hong Kong
Tel: 852-2837 0888 Fax: 852-2882 2792

Motic Instruments Inc. (Canada)

130-4611 Viking Way, Richmond, B.C., V6V 2K9 Canada Tel: 1-877-977 4717 Fax: 1-604-303 9043

Motic Deutschland GmbH (Germany)

Christian-Kremp-Strasse 11 D-35578 Wetzlar, Germany Tel: 49-6441-210 010 Fax: 49-6441-210 0122

Motic Europe (Spain)

C. Les Corts 12, Pol. Ind. Les Corts. 08349 Cabrera de Mar, Barcelona, Spain Tel: 34-93-756 6286 Fax: 34-93-756 6287

Website: <http://www.motic.com>

E-mail: info@motic.com.hk

Motic China Group., Ltd. (China)

Motic Building, Torch Hi-Tech Industrial, Development Zone, Xiamen P.R.C. Tel: 86-0592-562 7866 Fax: 86-0592-562 7855

© 2002-2017 Motic China Group Co., Ltd. All rights reserved. Motic is a registered trademark and service mark of Motic China Group Co., Ltd. Microsoft Windows logo is a registered trademark of Microsoft Corporation. All other trademarks are the property of their respective owners.

Design Change: The manufacturer reserves the right to make changes in instrument design in accordance with scientific and mechanical progress, without notice and without obligation.

