



Monmouth
Scientific

Operating & Maintenance Manual

Circulaire®
Powder Containment Booth

PCB1800



THE MARKET LEADER IN *CLEAN AIR SOLUTIONS*
www.monmouthscientific.co.uk

Contents

Section 1	3
Description.....	3
Section 2	4
Installation	4
General.....	4
Testing / Commissioning	4
Section 3	5
Operation	5
Section 4	6
Maintenance	6
Fuse	6
Light.....	6
Pre-filter	6
Main HEPA filter	7
Low airflow alarm	8
Section 5	8
Servicing.....	8

Warning

This cabinet must be used in compliance with these instructions and any repairs or maintenance carried out by qualified personnel.

**For parts or service information please contact Monmouth Scientific:
+44 (0) 1278 458090**

Section 1

Description

The Monmouth Powder Containment Booth provides local extraction and containment of powders handled within the filter capture zone. Refer to HSG258 for detailed guidance on application and suitable capture velocity.

The following capture velocities are achievable on this unit**:

Distance from centre of filter face	Max Velocity (m/sec)
10mm	2.1
30mm	1.7
50mm	1.5
70mm	1.3
100mm	1.15
150mm	0.95
200mm	0.8
250mm	0.65
300mm	0.6
400mm	0.4

**When fitted with new filters

A 2-stage Filtration system is used, with 2 easy-change, front inlet grille mounted course grade pre-filters to capture gross particulate and an H14 HEPA main filter to provide higher-level containment.

	PCB1800
External Dimensions	1800mm Wide 750mm Deep 2400mm High
Internal Dimensions	1700mm Wide 600mm Deep 1900mm High

Section 2

Installation

General

The cabinet may be delivered fully assembled or part assembled for final assembly on site by trained engineers who will ensure it is ready for use.

The following guidelines should be observed when installing and first using the cabinet:

Site the cabinet in a draught free position.

Connect the cabinet to a 13A socket.

Switch the cabinet on.

The red low airflow warning light will flash until the airflow has reached its correct velocity and stabilised.

When the green 'SAFE AIRFLOW' light is illuminated the cabinet is ready for use

Testing / Commissioning

A test certificate will be supplied for conformity to CE marking, and electrical test.

The airflow should be checked using a vane anemometer and the results recorded.

The main HEPA filter will have been factory tested before delivery.

A DOP filter challenge test should be carried out to verify filter integrity when the cabinet is installed.

THE CABINET SHOULD BE TESTED AT LEAST EVERY 12 MONTHS.

Section 3

Operation

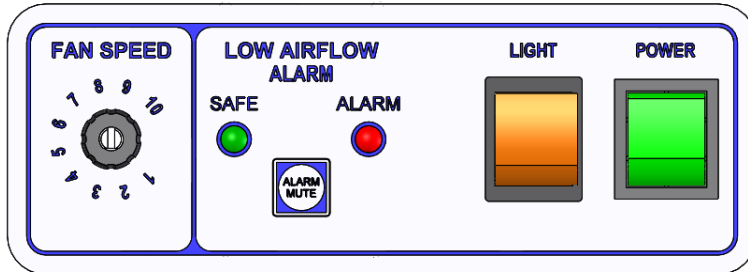

The booth is started by first operating the Green rocker switch on the control panel. The Red airflow monitor warning light will flash until the correct airflow is achieved.

The internal light may be turned on or off as required.

The airflow is constantly monitored. Should the airflow drop below a pre-set minimum level during operation, the red warning light will flash and an audible alarm will sound. The most likely cause is a blocked Pre-Filter which should be changed at the next opportunity (see section 4 for details).

The fan speed control knob is to be used for initial set-up and low airflow monitor calibration only (see section 4 for details).

Pre-Filters are available from Monmouth Scientific (see section 4 for details).

Section 4

Maintenance

The cabinet should be isolated from the electricity supply before carrying out any maintenance procedures.

Fuse

The main fuse is located in the power inlet socket on the left hand side panel. Always replace with the correct type and rating: 3A Type T

Light

The unit is fitted with a long-life LED lamp and should require no maintenance.

Filters

Replacement filters are available from Monmouth Scientific:

	Part number/qty required	
	Pre-Filter	Main HEPA Filter
PCB-1800	PF-1065 (x3)	K-HF0401 (x3)

Pre-Filter

These are located behind grilles on the front panel of the enclosure and can be changed by turning the thumbscrews and lowering the securing frame downwards.

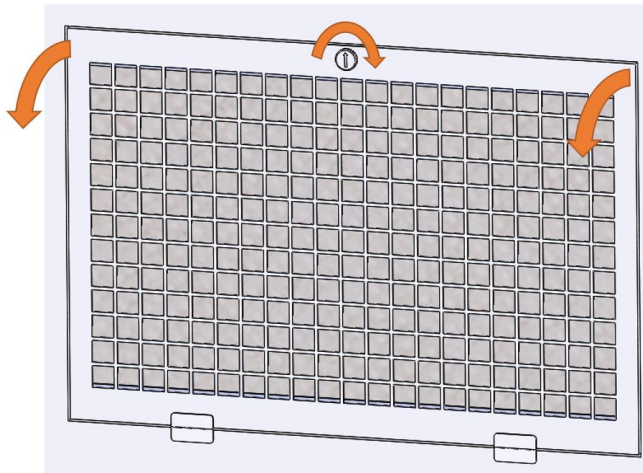

Main HEPA Filter

Replacement HEPA Filter Part Number: K-HF0401 (3 off/Cabinet)

- Using the supplied key, unlock and drop-down the access door.

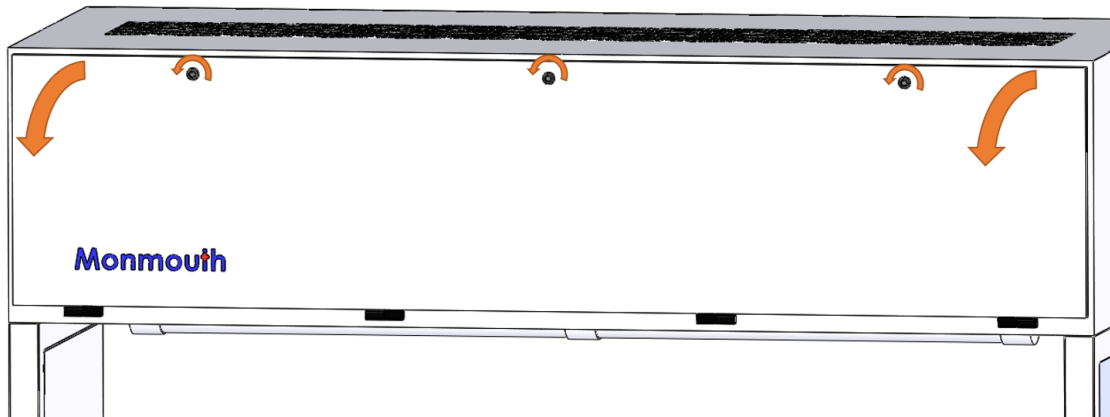

- Working inside the enclosure, in turn, slacken the 2 off screws (17mm A/F) clamping each fan box module to the filter. Work each side in turn to raise the fan box evenly until a sufficient gap is present to enable the removal of the HEPA filter which should freely slide out of place.

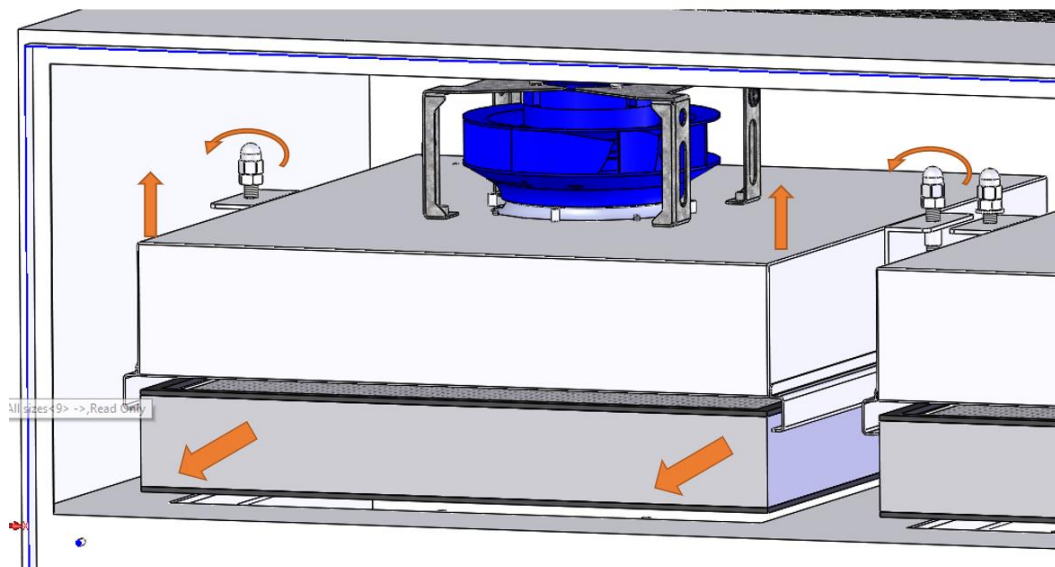

- To refit, check there is a sufficient gap and engage the new filter into the side guide rails taking particular care to ensure the seal does not drag on the bottom face and slide the filter all the way back until it rests against the backstop.
- Re-tighten the screws ensuring an even filter seal when fully tightened.
- The replacement filter should be DOP tested prior to use and the airflow and alarm re-calibrated if necessary.

Low airflow alarm calibration

For factory calibration purposes, the unit is set to alarm at 0.5m/sec with a boundary point 10mm from the filter face. It is recommended the user sets their own parameter to suit their specific application and limits.

- Turn off the cabinet and turn on again whilst holding down the 'ALARM MUTE' button. Release the button and the airflow indicator lights will flash Red/Green alternately.
- Using a 100mm rotating vane anemometer positioned at the required minimum capture velocity boundary point from the pre-filter face and by rotating the adjustment knob, adjust the fan speed to the desired minimum allowable velocity. Check in at least 3 positions per pre-filter to obtain an average and adjust as necessary.
- Wait approximately 20 seconds for the airflow to stabilise and press MUTE again to record the set point.
- The low airflow alarm point is now set and the system calibrated.
- Re-Adjust the fan speed back up to the normal operating velocity as required.

Section 5

Servicing

An annual service is recommended to maintain optimum operating conditions and will include the following points:

- Check / replace pre-filter
- DOP test the main HEPA filter
- Check airflow monitor and re-calibrate if necessary
- Check and record air velocity readings
- Check general condition of cabinet.
- Inspect electrical components, lighting, cables etc.
- Issue test report and airflow certificate.

**For parts or service information
please contact Monmouth Scientific: +44 (0) 1278 458090**

Monmouth+ Scientific

Monmouth Scientific Limited

UK Headquarters

Units 5 & 6 Kilnside,
East Quay,
Bridgwater,
Somerset,
TA6 4DB.

+44(0)1278 458090

www.monmouthscientific.co.uk

info@monmouthscientific.co.uk

